

SAFETY	1 - 15
MINI SPRINT	16 - 32
MIDGET	33 - 34
CHASSIS	35 - 41
FASTENERS	42
LIGHTWEIGHT	43 - 46
ENGINE	47 - 64
FITTINGS	65 - 66
FUEL	67 - 73
FLUIDS	74 - 75
TOOLS	76 - 85
TRAILER ACCESSORIES	86 - 88
FUN STUFF	89
BRAKE	90 - 96
SUSPENSION	97 - 105
WHEELS & TIRES	106 - 107
WHEEL ACCESSORIES	108 - 109
DRIVELINE	110 - 111
REAR END	112 - 114
FRONT END	115 - 118
STEERING	119 - 120
WING	121 - 123
TECH	124 - 133
INDEX	134 - 135



NEW!

Impact Carbon Fiber Draft

High-bypass air induction system that circulates air around the head and face. Adjustable forehead vents are channeled to dual rear exhaust vents. Plus nose/mouth chinbar vents. Shell construction featuring proprietary American space age composites for an ultra light helmet. Gray Matter™ liner. Impact's 'intelligent' single piece variable density liner, upholstered with a lightweight fire resistant fabric. Interchangeable cheek pads for a custom fit.

Adult sizes: XS/S/M/L/XL **\$1400.00**Also available in Silver/White/Gloss Black/Flat Black **\$755.00**

BELL

NEW!

Bell Dominator

- Lightweight and aerodynamic
- Most comfortable Bell helmet
- Available in White and Flat Black
- Fleece lined bag included

\$799.99 (specify size and color)

NEW COLOR!

**Impact Charger**

The Charger™ features an oversized wrap-around eye port for wide angle panoramic vision. Impact's computer generated

shell and liner are matched to offer a secure, comfortable and consistent fit. Something you'll appreciate every time you put the helmet on. Chin Whisker/Barrier seals under helmet to prevent air contamination.

Adult sizes: XS/S/M/L/XL Silver/White/Gloss Black/Flat Black

\$459.99

NEW!

Bell GTX Helmet

A light weave shell with ultra high speed aerodynamics. Available in sizes 6 7/8 through 7 3/4. Black or white. **\$579.99** (specify size and color)



BELL

NEW!

Pyroprotect Airflow Helmet

The best helmets on the market for the money today! Nomex REMOVABLE liner with replaceable cheek pads and excellent chin coverage.

Wide eye port for peripheral vision and shields that close nice and tight. Fully painted or solid white and black painted colors available.

You won't find a nicer helmet for the money. Sold in XXS-XXL

\$248.99 White or Black \$278.99 w/Graphics

PYROTECT



BELL

Bell Vortex.2

New for 2009. Smooth exterior with adjustable vents. Carbon X interior. Light weave Carbon composite shell construction and excellent ventilation. Great shape for larger heads. Well designed helmet at an affordable price. Available in white, black and flat black. **\$579.99**

Bell Breath Deflector

Bell made it easy to install your own breath deflector. Simple and effective. #BEL BR1001 **\$23.99**



BELL

Simpson Speedway Shark

Sprint car racing's favorite helmet. Most vents of any helmet on the market. Wide shield area for great peripheral vision. Fits well into full containment seats. Comes with padded helmet bag, clear and smoke visors.
White \$699.95
Black/Flat Black \$724.95



Diamond Back Helmet

Fits everybody! Tons of chin room! Lightweight Carbon, Kevlar and Fiberglass composite shell, unique diamond pattern crown design, Carbon X Interior
 Contrasting vents for added appearance.
White \$569.95
Black/Flat Black \$594.95



Simpson V-Sport Helmet

Simpson introduces a value priced helmet, the V-Sport. The V-Sport is Snell SA rated and designed to provide exceptional quality in a proven helmet design featuring a comfortable impact absorbing and form fitting liner. The helmet ships with an extra set of cheek pads and a 3mm Clear shield. Simpson serves up safety and affordability from a trusted brand in racing safety. Large Eyeport for Maximum Line of Sight. Removable Cheek Pads.

NEW!



Colors: White
 Sizes: S-XXL
\$249.99

Nomex Breath Deflector

Helps seal the mouth and nose area, keeping fresh air in and unwanted fumes out. Also helps prevent fogging.
 #SIM 97022 **\$99.00**
MUST BE FACTORY INSTALLED
 We stock helmets with them installed



Super Bandit

Simpson's most popular helmet for decades. Lots of nose and cheek room. Fits great with the HANS. Fire resistant interior, high gloss shell, adjustable vents. Comes complete with a clear and a mirrored shield.
 Available in all colors. See color chart above.
White \$499.95
Black/Flat Black \$524.95



HELMET SIZING CHART

INCHES	20	21	22	23	24	25								
CENTIMETERS	51	52	53	54	55	56	57	58	59	60	61	62	63	64
HAT SIZE	6 5/8 - 6 3/4		6 7/8 - 7	7 1/8 - 7 1/4	7 3/8 - 7 1/2	7 5/8 - 7 3/4	7 7/8 - 8							
HELMET	XS	SM	MD	LG	XL	XXL								

All Simpson Helmets available in: White, (Black, Matte Black, Metallic Silver, Metallic Blue - Add \$25.00) (Red, Yellow, Safety Orange, Metallic Bronze, Maroon, Metallic Pearl - Add \$50.00) and (Rattlesnake - Add \$100.00)

SAFETY NOTES

HELMET FIT:

A correctly fit helmet should feel as if an evenly distributed pressure is continuously being exerted around the head and cheeks. Helmets, like shoes, will break in. For this reason, the helmet should fit as tight as you can stand to wear it. Once fastened, make sure the helmet cannot be pulled off the head in any direction. If the helmet moves significantly, the helmet is too big. Many people, especially first time helmet buyers, tend to pick helmets that are too loose or too big. If the helmet is too big or too loose and doesn't fit well, then it cannot deliver the best protection.

SAFETY



Hybrid Pro Head and Neck Restraint

The revolutionary R3 Head and Neck Restraint moves with the driver during a crash, maintaining the relationship of the head, neck and torso. Designed with a low neck for easy exit, engineered with molded seat pad to disappear and does not rely on seat belt harness for restraint.

- > New Side Stabilizing Gusset Load Path for Unbeatable Angular Protection
 - > Patented Seatbelt Anchoring System for Incredible Security. The harness controls your motion.
 - > Sizes S-XL
 - > SFI 38.1 Certified/FIA Institute Approved Carbon Fiber Design
- \$995.00**
All devices in stock come complete with Vision Maxx Tethers.



Hybrid Pro Rage

The Pro Rage is the latest addition to the Rage line. Ultra small so you don't have to modify your seat, the Pro Rage has been extremely popular! Staying true to multiple impacts and superior protection in angular and side impacts, the Pro Rage has it all. From the patent pending SSG (Side Stabilizing Gusset) to the patented Seatbelt Anchor System, we give you great coverage at an unbeatable Price. A combination of composite and carbon fiber.

SFI 38.1 Certified ~ Same advantages as lightweight series ~ All around protection ~ Comfortable by design ~ Easy to Exit ~ Great protection starting at an affordable price of **\$649.00**

R-3 SIZING CHART

Extra Small	32"	36"
Small	36"	40"
Medium	40"	44"
Large	44"	48"
X-Large	48"	52"
Custom*		

Measure just below pectoral muscles with suit on.



DefNder Head & Neck Restraint

The defNder addresses some of the aspects of the other leading head and neck restraints on the market today. From belts slipping off, the discomfort of bruising around the base of the neck and collarbone, the difficulty of working the release mechanisms, being pushed forward and literally out the front of the seat, the defNder has offered a solution to these concerns. With the adjustable

features and dual tether system that make the defNder a one size fits most product, and it has passed the extremely tough SFI 38.1 test standard.

One Size \$549.00!!

HANS Professional Series Device

The new HANS Professional Device is built from Hand Laid Carbon Fiber for the ultimate lightweight head and neck protection. New design comes complete with Vision Advantage Sliding Tethers for full head movement at no extra cost. The lightest device yet. All installation tools, helmet posts and instructions provided with the device.
#HAN 20x **\$1045.00**



HANS Sliding Tether Replacement Kit

All of the new HANS devices come complete with tethers that slide allowing driver to fully rotate head comfortably. HANS devices built prior to 2008 can be updated with this simple kit.

Just 4 screws will make a big difference in comfort for the driver.
#HAN K9041
\$75.00



HANS Sport Series Device

Hans created an economy version of familiar professional device for the Saturday night racer on a budget. Built from a revolutionary carbon fiber composite. A little heavier than the professional version, but the tough standards have not changed.
\$695.00



SIZE SELECTION GUIDE

The width of the HANS® collar is sized to fit your neck or shirt collar size.

- Under 12 Inches - Size Extra Small (XS) (For people under 100 lbs.)
- 12 to 15 Inches - Size Small (S)
- 15 to 18 Inches - Size Medium (M) (Called size REGULAR on older models)
- Over 18 Inches - Size Large (L)

Replacement Shields

We stock all replacement shields for any helmet we sell.

Simpson Clear, Smoke or Light Smoke Anti-fog Shields \$45.00

Simpson High Resolution Amber Shield \$50.00

Simpson Metalized Blue Blocker Iridium \$70.00

Bell Clear, Amber, Smoke \$53.50

Bell SilverChrome \$65.99

Impact Clear \$49.99

Impact Smoke \$55.99

Impact Amber \$59.99

Impact Chrome \$63.99



Dual Shield Bag

The dual shield bag is designed to hold two shields with separation between. Made with micro fiber, it can be machine washed. Excellent for storing shields.
#SIM 23900 **ONLY \$5.00**

One Way Driver Radio

These great little inventions have sped up races all over the country. This kit comes complete with a small drivers suit clip, headphones and a personal one way radio. Headphones also sold separately.
Complete Kit #RCV 1600 \$150.00
Headphones only #RCV EPD \$29.99



Racing Optics Tear-Offs

Available for all helmets! The ultimate sprint car tear-off.

Voyager Helmet #ROI 7201

All Bell & Pyroprotect Helmets #ROI 7202

Diamondback and Bandit Helmets #ROI 7204

Shark, Valor, and Vudo #ROI 7209

Bieffe #ROI 7215

Impact #ROI 7230

\$24.95 / Sleeve \$110.75 / Box

BEST VALUE!



Ultra Shield Aluminum Tear Off Posts

An economical way to stack extra tear offs on your visor.
#ULT 1912 **\$5.95**



Ultra Shield Tear-Offs

- Approximately 200 per case
- Voyager #ULT 1201**
- Bell/Pyroprotect #ULT 1202**
- Diamondback and Bandit #ULT 1204**
- Shark #ULT 1209**
- Bieffe #ULT 1212**
- \$17.99 / Box**
- Impact Vapor/Charger #ULT 1230**
- \$19.99 / Box**



Racing Optics Tear-Off Posts

The only way to stack enough tear offs for a muddy night. Tapered posts that install in the current location. The way to go for dirt sprint car racing.
#ROI POSTS **\$12.95**

Hans Mounting Post

Sold Separately for second helmet.
#HAN POST **\$65.00**



Rain X Anti-Fog Singles

An easy way to keep from fogging up. Will not damage the new shields with the anti-fog coating.
#RAX AF5 **\$1.95 ea**



Deluxe Super Racer Gear Bag

Full capacity gear bag for any type of racing. Tunnel pocket underneath with foldout mat for changing built right in. Vented side pockets and front pocket long enough for tear-offs. Fits 2 helmets and all gear! 28" x 13" x 15"

#SIM 23420 **\$79.95**



Simpson Storm Pack

18"L x 13"W x 7"D
Tons of pockets gives this awesome backpack room for everything you might carry. IPOD pocket, too! A GREAT VALUE!
#SIM 23804 **Only \$39.99**

NEW!

Impact Gear Bag

Impacts 3 compartment Gear Bag is designed to hold your helmet, suit, gloves, shoes and accessories, but will readily double as travel luggage as needed. Super Sturdy! 27" x 12" x 11"

#IMP 72000
Only \$49.99



NEW!

Simpson Small Duffle Bag

24"L x 11"W x 12"D
Carry-on sized gear bag with large vented main compartment as well as side and front storage compartments.

#SIM 23430
\$39.95



NEW!

Deluxe Trackside Gear Bag

33.5L" x 16"W x 16.5"D
Our biggest bag offered for all your gear. Plenty of room for your helmets, gloves, shoes and more.

#SIM 23620 **\$179.95**



GREAT FOR TRAVELING!



TOP: #RNG 403-xx \$89.99
Sizing Sm-XXL

Under X™

Carbon X Long Underwear

Under X offers excellent protection with amazing fire resistant characteristics, inherent moisture wicking properties, and comfort. **NON-FLAMMABLE:** Under X will not burn, melt, shrink or drip when exposed to heat and flames. **COMFORT:** Under X fabrics are cool and comfortable.



BOTTOM: #RNG 413-xx \$89.99
Sizing Sm-XXL



HEADSOCKS:

Single Eyeport #RNG 423.20

Dual Eyeport: #RNG 423-10 \$45.00



SHOE LACES:

#SIM FRLACES
\$9.99

Fire Retardant



CARBON X SOCKS:

#CBX-SOCKS **\$31.99**
19" lengths in black
One Size Fits All.



O-Carbon X

O-CarbonX is a unique blend of advanced fibers in a light weight construction developed specifically for Oakley. This special version of CarbonX maximizes key performance elements including: safety/protection, weight, breathability, moisture wicking, and durability creating the highest performing base-layer products available in the marketplace.

O-Carbon X Top \$112.99
O-Carbon X Bottom \$112.99
O-Carbon X Head Sock \$45.00
O-Carbon X Socks \$31.99

Looking for Jr. Sizes?

Go to page 15 & check out our Junior Safety Section! We've got what you need!

Alpinestar Tech 1-Z Driving Shoe

Alpinestars' Tech 1-Z racing shoe is developed in conjunction with Formula 1 and Sports car drivers. Featuring a form-fitting Kangaroo leather construction with Nomex® lining for the ultimate in strength and performance, while Alpinestars exclusive rubber compound outsole provides the driver with the optimum in feel at all times. Worth the money! The most comfortable shoe we've ever had.

Sizes 5-13
\$289.95



NEW!

IMPACT

NEW!



Impact H/T Bolt

The H/T Bolt is the high-top solution for every racer. Made with a grooved sole for cooling and traction. It provides the perfect blend of comfort, pedal feel and support. Reinforced heel and toe panels with an adjustable ankle strap.

Sizes 7-14
\$115.99

Oakley RACE Mid Shoe

Patented CarbonX® flame-resistant lining outperforms all known standards on the NFPA 2112 Flame Resistant Garments testing protocol. Self-extinguishing split suede for comfort and



flexibility in a mid-rise design. High-grip

NBS vulcanized rubber outsole, optimized for tactile response on race pedals. Low-density advanced polymer EVA midsole for heel support and resilient shock absorption CarbonX® batting and fire-retardant leather heel counter / inner sole for added protection. Brand new and ultra comfortable!

\$169.99
Sizes 5-13



Stealth Driving Shoe

All new modified lace guard that completely covers forefoot. SFI Tag included. New and improved softer leather, fleece Nomex lining with flat seams and athletic insert. Sloping Achilles heel design with wrap-around ankle support.

Sizes 4-14.
#SIM SPxxx \$129.95

The Fusion Driving Shoe

The Fusion is designed to move the way good footwear should, especially in the demanding environment of racing. The leather offers great protection, and the sole gives you excellent pedal feel. The comfort provided by the Fusion Driving Shoe is unmatched. Sizes 4-14. \$129.95



Adrenalin Driving Shoe

A new stylish shoe with a great sole for better grip on pedals and floor pan. Satin suede toe, heel and lace guard reinforcements. Triple layer anterior toe area for added wear protection.

Low cut Achilles support for maximum flexibility. Fleece Nomex lining.

Available in Black, Blue and Red. Sizes 4-14.

#SIM ADxxx
\$119.95



SAFETY

NEW!



\$125.00

Available in Black, Blue and Red

Oakley Professional Racing Gloves

These professional driving Gloves are made with patented Carbon-X materials along with Pittards Fire retardant leather, these gloves are the ultimate in safety while leading the way with a style that's all Oakley.

- SFI approved
- Kevlar lined palm provides additional line of defense against flames and heat.

Alpinestars Tech 1-S Glove

2-Layer Nomex construction. Palm constructed of durable fire retardant leather for maximum protection and grip. Pre-curved fingers construction for superior comfort. External palm side seam construction for precise fit and sensitivity. Diamond digital palm patch for added grip. Minimum palm padding for superior grip and feel.

Sizes S-XXL **\$129.99**

NEW!



Ringers Driver X Driving Glove

CarbonX construction with all CarbonX Gauntlet with elastic forearm cuff and wrist.

Premium treated leather palm.

Unique palm design reduces high wear area seams. 3/4 closed anatomic design put your hands in the most comfortable position when at the controls.

Quick grab Velcro® wrist adjuster.

\$89.99

Sizes XS-XXL



NEW!

Ultrashield Kids Gloves

Finally a glove suited just for kids. Sized just perfectly to fit kids fingers without bunching up. Available in Black, Blue and Red.

#ULT 411xx **\$39.99**

NEW!



Simpson Sportsman Glove

The Sportsman Grip Driving Glove is the right choice for fit and feel when running on a tight budget. Same Simpson quality throughout without the extras. If you've got a limited budget, the Sportsman Grip is the right choice.

Sizes XXS-XL (Great for small kids)

#SIM 22500

\$69.99

Undercover Glove

Soft and comfortable leather palm with padded knuckles and an easy-fitting Nomex wrist cover. Constructed entirely with Nomex and includes an SFI Tag.

SIM 209xx **\$99.95**

Available in Black, Blue and Red



Go to page 15 & check out our Junior Safety Section! We've got what you need!

GLOVE SIZING

To find Glove size in inches, measure around the largest part of your hand over the knuckles while making a fist, excluding thumb.

XX-Small	5 to 6
X-Small	6 to 7
Small	7 to 8-1/2
Medium	8 to 9-1/2
Large	9 to 10-1/2
Extra Large	10 to 11-1/2



Impact Racer Driving Suit

The Impact Racer offers the best value in American-made racing suits today. The Racer is made with the same standards as the custom firesuits but sold at budget racer price.

Any other suit maker charges extra for 360 degree arm gussets, boot leg cuffs and expandable lower back gussets. This is an SFI approved 2 layer suit that will fit in your budget. Great fit and sized well to fit a broad range of body styles.

NEW!

Sizes S-XXL
\$499.99

Impact Team One Driving Suit

Looking for a suit that's a step between the Racer and the full custom suit? Our Team One suit comes with all the same quality features as the Racer (floating arm sleeves, boot leg cuff, expandable lumbar gusset, and inset front pockets) but in a higher-quality semigloss finish Nomex Outer Shell. Definitely has a shinier appearance than any other suit at this price.

Sizes S-XXL
\$699.99

NEW!



Alpinestar GP-1 and GP-T 2 Layer Nomex SFI 3.2A/5 Driving Suits Construction

Two-layer 100% Nomex® construction made with Alpinestars' unique and distinctive, ultra-lightweight, Rip Stop outer-shell, which combines excellent breathability and minimal weight with a high level of safety protection against fire and heat transfer. A lightweight internal knit fabric layer makes this suit extremely comfortable with high breathability performance. Telescopic panel construction for perfect fit and movement in the driving position. Ergonomic flex zones. Full floating arm constructed with a knit fabric that stretches in all directions. Specifically shaped shoulder, arm and leg pattern for an ergonomic fit in the driving position and lumbar stretch panel to add comfort in the cockpit.

Comfort and convenience

Soft collar made with knit fabric for supreme comfort. Internal layer construction has been developed to avoid any pressure points. Shoulder construction incorporates Alpinestars' unique "grab" handle panels to aid driver extraction and maintain comfort with HANS device and belts.

Boot Cut finish

Specific styling for the US racing market, designed and developed with the top drivers in Alpinestars' NASCAR program. Alpinestars' distinctive "Astar" logo on arms and lower legs.

Colors - Black, Red, Silver, Blue, Yellow

Sizes - (EUR) 44 to 60 (See sizing chart below)

#ALP GP-1 \$749.99

#ALP GP-T \$799.99

New GP-T Driving Suit available in Black/Grey, Grey/Black (pictured), Red/Black and Blue/Black

New GP-T coming February 2010
New design/new fabric/
SAME QUALITY!



NEW!

SIZE 40	
A	30" 3/4-32" 5/8
B	25" 1/4-26" 3/8
C	30" 3/4-32" 5/8
D	24" 3/4-26"
E	4'10"-5'1"

SIZE 42	
A	32" 1/4-33" 1/2
B	26" 3/4-28"
C	32" 1/4-33" 1/2
D	25" 1/4-26" 3/8
E	5'-5"2"

SIZE 44	
A	33" 7/8-35"
B	28" 3/8-29" 1/2
C	33" 7/8-35"
D	25" 5/8-26" 3/4
E	5' 1"-5' 4"

SIZE 46	
A	35" 3/8-36" 5/8
B	29" 7/8-31" 1/8
C	35" 3/8-36" 5/8
D	26"-27" 1/8
E	5' 2"-5' 7"

SIZE 48	
A	37"-38" 1/8
B	31" 1/2-32" 5/8
C	37"-38" 1/8
D	26" 3/8-27" 1/2
E	5' 5"-5' 9"

SIZE 50	
A	38" 5/8-39" 3/4
B	33" 1/8-34" 1/4
C	38" 5/8-39" 3/4
D	26" 3/4-28"
E	5' 7"-5' 11"

SIZE 52	
A	40" 1/8-41" 3/8
B	34" 5/8-35" 7/8
C	40" 1/8-41" 3/8
D	27" 1/8-28" 3/8
E	5' 8"-6'

SIZE 54	
A	41" 3/4-42" 7/8
B	36" 1/4-37" 3/8
C	41" 3/4-42" 7/8
D	27" 1/2-28" 3/4
E	5' 10"-6' 2"

SIZE 56	
A	43" 1/4-44" 1/2
B	37" 3/4-39"
C	43" 1/4-44" 1/2
D	28"-29" 1/8
E	6'-6" 3"

SIZE 58	
A	44" 7/8-46"
B	39" 3/8-40" 1/2
C	44" 7/8-46"
D	28" 3/8-29" 1/2
E	6' 1"-6' 5"

SIZE 60	
A	46" 1/2-47" 5/8
B	41"-42" 1/8
C	46" 1/2-47" 5/8
D	28" 3/4-29" 7/8
E	6' 2"-6' 6"

A = CHEST
Measured around the chest.

B = WAIST
Measured around the natural waistline.

C = HIP
Measured 7 1/2" down from the natural waistline.

D = INNER LEG LENGTH
Measured from the crotch to the ankle bone.

E = HEIGHT

Pyrotect Sportsman Deluxe SFI 5 Suit

The only well-priced suit with a Nomex fabric on the outer layer. These are well-designed suits with 360 expansion panels, waist expansion panels, boot cuffs and hidden pockets. They fit great and have an easy care design. Available in black/red, red/black and blue/white.

#PYR 210xxx **\$325.00**
XL add \$35.00
2XL add \$50.00
3XL add \$60.00



Pyrotect Single Layer Suit

The best value in single layer suits. Fits very well. Comfortable, flexible, straight leg cuffs, inset pockets, high rise collar and European Styling. SFI-1 approved. Available in red, blue and black.

Sizes S-3XL **\$101.99**
2XL add \$15.00
3XL add \$30.00



Simpson Sportsman Elite 2 Layer Suit

Simpson's Best Value Suit. SFI .5 Rating. Gabardine Nomex. Contrasting Platinum chest band and extensive white piping. Matte finish, banded collar, 360 degree arm gussets, epaulets and straight leg cuffs. Great spot on front and back to embroider logos and driver name. Available in black, red and blue.

#SIM STD.14 **\$529.99**
2XL add \$75.00

Impact Custom Suits

Impact's custom firesuits are made in the USA and are the culmination of Bill Simpson's 50 years of race safety experience. Choose from 16 colors and 12 styles. The fabric is an Ultralight Nomex with a very shiny appearance only available from Impact Racing. Sponsor logos, driver name, custom artwork all available to add to this very professional driving suit.

2 Layer Base Price **\$1254.99**
Built in Arm Restraints **\$55.00**
Boot Leg **\$60.00**
Impact Racing Embroidery **\$FREE**
Name Embroidery **\$FREE**

NEW!



SpeedMart Custom Driving Suits



We've contracted our suits with both Simpson and Design 500. Super high quality suits, custom fit and measured for you!!!! Both have 3 point epaulets, full expansion joints, 3 tone color schemes, arm restraints built right in, and boot legs. This same suit without our logo would be \$2-300 more. Your choice of color on sleeves and collar, your name on the suit, and our logos front and back!

Simpson Suit Pricing:

Gabardine Nomex **\$785.00**
 Sateen Nomex **\$845.00**
 Signature Knit Nomex **\$995.00**
 Arm Restraints add **\$65.00**

Design 500 Pricing:

Filament Nomex **\$1400.00**



Design 500 Custom Driving Suits

Design 500 2 Layer Driving Suit

Filament Knit Nomex. VERY flexible and breathes well. Lots of stretch qualities for ultimate comfort and cooling.

Colors available: Red, White, Yellow, Royal Blue, Navy, Black, Silver, Purple, Orange
 2 layer base price **\$1,100.00**

Custom Suit options:

Boot legs w/inset cuffs-2 layer w/CarbonX, quilted **\$90.00**
 Boot legs w/inset cuffs and hoof **\$165.00**
 Built-in arm restraints with restraint straps (pair) **\$75.00**
 3-Point epaulets **\$25.00**
 Piping on collar, belt, epaulets & banner **\$50.00**
 Extended shoulder w/inset sleeves, 360° shoulder gussets **\$90.00**
 Extra layer of CarbonX on bottom half of suit **\$125.00**
 SFI/3.2A patch **\$10.00**



Ultrasield Lightweight Halo Seat

Ultrasield Full Containment Seat for adults or juniors. Sizes all the way down to a 11" and up to a 18" in 1/2 size increments. Super comfortable with the HANS device and fits nicely into mini sprints and sprint cars. Modular upholstery allows for increased driver feel in car. Available with lowered rib supports for juniors. Built with a C channel stiffener in torso area that clears the A frame of most cars.
#ULT 72000
\$651.99



NEW!

Butlerbuilt Standard Sprint Advantage Seat

Built with exactly the same quality as the Custom Sprint Advantage Seat but available in standard sizing to allow drivers to buy one "off the showroom floor" for the first time. Fits a variety of driver's builds and sold complete with modular padding for a great price.
Sizes 14-17 in 1/2 sizes
\$719.99



NEW!



Sprint Advantage Custom Fit Seat Butlerbuilt

The new advantage head and neck support system was developed and designed to address recent head & neck concerns. Crash sled tested at Autoliv's in Auburn Hills, MI facility. The advantage system greatly enhanced occupant safety. Custom fit to your measurements, and includes black, red, blue, or grey padding.

You won't ever buy another brand of seat again!

Compatible with HANS and R3 Head and Neck Restraints.

\$1345.00

Powder Coating Available \$135.00

Now more room for HANS device!



Kirkey Adjustable Full Containment Seat

Finally a full containment seat that will grow with the driver. Shoulders move in and out 1 1/2" and head system moves up and down 3" allowing driver to grow. With the speeds the cars are traveling, it is important to have the driver's shoulders and neck supported no matter what type of race car.



#KIR 66xxx **\$914.99**

Padding \$135.99



Sprint Deluxe LW Seat

Kirkey's most advanced sprint car seat. Features radiused punched lightening holes, double wall construction, and widened seat belt openings. The most popular seat for weekly racers. Upholstery available in black, red, blue, purple, and grey.

#KIR 56XXXLW **\$314.99**

With Upholstery \$75.99

Kirkey Mini Sprint Seat

An all new seat designed specifically for mini & micro sprints with the kids in mind. The shoulder holes & rib supports are proportional to a lower torso for added safety!

#KIR 52XXXLW

\$249.99

Upholstery \$73.99



The Ultimate Steering Wheel

The coolest steering wheel we've ever seen stock! 15" Diameter with CNC holes in all possible locations. 1 1/8" Grip for reduced hand fatigue. Very light but very strong. Precision built. Silver or Black available.
 #JOE 13535-A **\$79.99** (Silver)
 #JOE 13535-B **\$82.99** (Black Anodized)



Butlerbuilt Aluminum Steering Wheel

The 1 1/4" version is the widest grip steering wheel on the market. Available on 1" or 1 1/4" tube for reduced hand fatigue. 15" or 17".
 #BUT 1X-X **\$82.95**
 Powder Coated Black or Red Available



JOES Steering Wheel Tape

Stops your hands from slipping on the wheel and keeps gloves from ripping.
 #JOE13600 **\$6.99**



Kirkey Mini Head & Neck Restraints

Just like the full size, just scaled down to adapt to the smaller seats easier! A perfect addition to your standard seat.
 #KIR 98611 **\$379.99**

Kenny's Components Half Box Knee Guard

Kenny's COMPONENTS
 704-528-6481
 Carbon Fiber



Simplify the knee guard system in your sprint car. Fits just after the 1/2 box mount and locks in place on the right side. Full protection on the left side from the steering box. Very simple!
 #KEN HKG **\$69.99**

Kirkey Head & Neck Restraints

Our favorite new item of the year! This complete system will bolt onto ANY Kirkey seat! Great for growing kids. Reusable for various seats, just unbolt the whole system.
 #KIR 98711-S **\$381.99**



J & J Gen 2 Knee Guard

Built for the Generation 2 Knee Guard with no extras on the right side where there is no steering gear shaft. Solid aluminum with padding for extra knee protection. Will fit any brand of car.
 #JNJ 101038 **\$49.99**

NEW!



Kenny's Components Carbon Fiber Knee Guard

From the leader in carbon fiber sprint car racing components comes this ultralight, yet padded sprint car knee guard. Designed to fit with any steering gear, and easy to mount. The nicest one we've ever seen! Used by many of the Outlaws.
Full Padded
 #KENFKG-P **\$79.99**
Half Unpadded #KEN

Kenny's COMPONENTS
 Carbon Fiber



NEW!



Kirkey Sprint Knee Guard

Lightweight aluminum formed to surround center steering unit & bead rolled for extra strength. Covered with fire retardant foam. Simple to mount! The only knee guard made that protects driver around the Gen 2 steering gear.
 #KIR 99500 **\$59.99**



Child Seat

Very economical seats for the youngsters in 1/4 midgets or micros. Sizes 10-14".
w/ upholstery
 #KIR 24XXX **\$165.99**
 Colors blue, red, black.

Economy Seat

The perfect seat for mini stocks, hornets, or other flat bottom cars.
 #KIR 19x00 **\$114.99**





NEW!

Simpson HANS Harness

Designed specifically for the driver who wears the HANS. The 3" belt secures the driver in the car and the 2" belt supports the HANS. Now the driver will have the secure feeling from the 3" belts and the HANS will rest on top of the 3" belt! EZ pull latch system makes buckling up a snap!
#SIM 290-HAN \$191.99

Impact Hans Double Shoulder Belts

Designed with comfort and increased safety in mind. 3" shoulder belt with an integrated 2" shoulder overlay that fits the HANS and allows the HANS to be secured while the driver is secured to the car with the full 3" belt.
#IMP 5111111WH \$145.99

NEW!

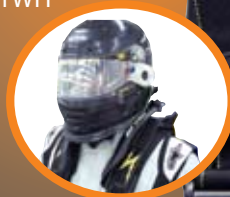

Crow Single Pull Belts

Compact buckles make them super comfortable, and easy to buckle up. We have these in "pull-down" (standard for full size sprints) or "pull-up" (standard for Mini Sprints or Hornet cars).

Available in Red, Blue, Black, Purple and Silver
#CRO 2005x \$94.99



Sternum Strap Addition

Crow Sprint Car Belts w/ Sternum Strap

\$121.99

Simpson Wrap Latch FX

More pulling leverage because belts pull at buckle. Sternum Strap available. Available in blue, black, or red. Ideal for open wheel cars!
#SIM 29072x \$114.95
w/ Sternum #SIM 29072xWS \$156.95
Platinum Upgrade \$21.00



Sternum Strap Addition



Latch



Impact Latch and Link Belts

Impact restraint systems are proudly made in the USA with the highest quality parts and craftsmanship money can buy. All of our restraints feature yellow contrasting stitching for immediate inspection of seam integrity and are SFI Approved and available with 16.1 certification. All belt mounting ends are wrap-around and anchor hardware (bolt-in, clip-in or eyebolts) can be added as needed.

Our belt centering system on the pull-ends keeps webbing centered in the adjusters after tightening for proper belt/hardware alignment for maximum effectiveness. Our belts also come with our new and improved Quick Adjuster hardware.

#IMP 51111111 \$119.99



NEW!

EZ Seat Belt Tightener

Finally, an easy to use seat belt tightener that allows a crew member to get a driver tighter in the race car! A great tool to have.
#VRP 2515 \$39.99

**Arm Restraint Singles**

For those suits with arm restraint loops built in. Sold in red, blue or black.

With Metal Loops
#DES ARP \$15.99
Fabric Loops
#SIM 54018xx \$14.95

**NEW!****SAFETY NOTE****Equipment Familiarity:**

Follow all the instructions when installing your restraints. Mounting angle, mount strength and belt path are all critical to a proper mount. Frequently inspect your restraints for wear and abrasion. Replace any restraint involved in a crash with a new set. With crashes in excess of 100 g's becoming more common, you don't want to compromise your safety.

SAFETY NOTE**Equipment Familiarity:**

Become familiar with the installation, use and operation of all your safety equipment. Practice exiting the vehicle with all your equipment in an efficient manner. Remember that it may be difficult to see in certain crash situations. Practice should include exits by "feel" without the use of sight.

CROW ENTERPRISES**Crow Drag Link Strap**

Required at most sprint car tracks! Connects the drag link to the frame, not allowing it to flop around if it comes disconnected.

#CRO 11646 \$12.99

CROW ENTERPRISES**Crow Roll Cage Net**

- Sprint/Midget roll cage net with quick release buckle
- Fits left or right side of roll cage
- Black, red, silver, blue, or purple available

#CRO 116XX \$34.99

**Simpson Helmet Restraint**

#SIM 36007X \$13.95

**Simpson Arm Restraints**

Sold in pairs. Complete with straps to connect arm restraints to seat belts.

Red, blue, and black available.
#SIM 36001X \$41.95

**Simpson Neck Collar**

Simpson's Exclusive High Density "Compression Spring" Foam Neck Collar. Comfortable, round design. Available in blue, black, or red.

#SIM 23022X \$39.95 (Specify Color)



Different Mounting Styles Available (Crow or Simpson)

SAFETY NOTE**Restraint Inspection:**

Restraints must be maintained, inspected, and replaced every two years in accordance with SFI 16.1 Specifications. Testing shows that the webbing degenerates from exposure to the elements over time. Prolonged exposure of seat belt webbing and thread to sunlight can cause degradation of the fibers and loss of restraint integrity.

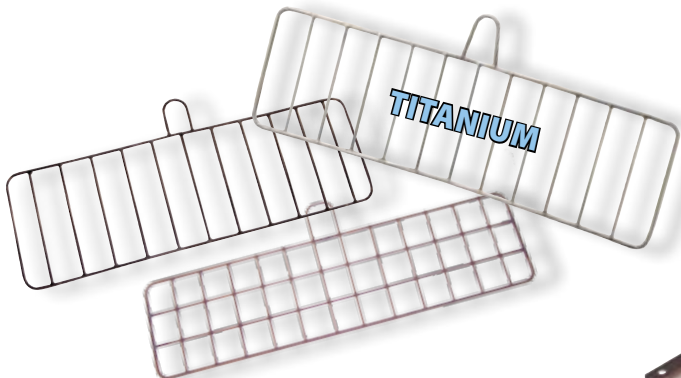

Sprint Car Rock Screen

A driver once said, "Cover your eyes. What do you see?" Use One!

4130 Powdercoated Black #HRP 8069 \$63.95

Crossbar Rock Screen #WIR ROCSC \$43.99

Titanium #T22 1029T \$159.99

Alpinestar Crew Gloves with Magnet

Lightweight and flexible mechanic's glove. Synthetic suede leather palm construction. Lightweight and breathable ribbed spandex top. Enclosed magnet to hold small screws and bolts. Velcro® wrist strap closure. Plastic print detail on top of finger. Velcro® wrist closure. **\$29.99**



J&J Aluminum Sprint Car Visor

Built to fit any sprint car with single or double wing mounts. 7 1/2" long in center for great sun coverage. **\$65.99**

Paulson Bubble Goggle

These are the cat's meow. Controls 99% of dust. A great gift for crew guys or fans!
Clear: #PAU 100 \$11.95
Amber: #PAU 300 \$11.95

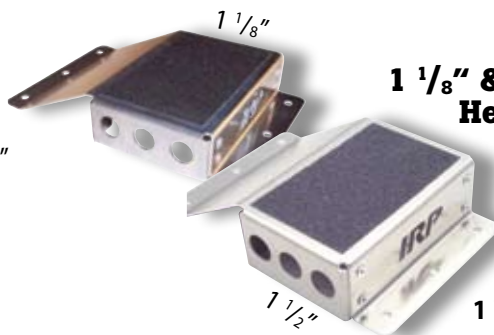

1 1/8" & 1 1/2" Heel Blocks

Non skid on top. The best heel blocks on the market. Pre-drilled Rivet Holes even!
1 1/8": #HRP 8062 \$22.99
1 1/2": #HRP 8063 \$22.99

Hi Density Roll Bar Padding

High density roll bar padding that doesn't look bulky and won't drip or melt in a fire. Red or Black.



Black: #LON 65182 \$12.95
Red: #LON 65184 \$12.95

Foam Roll Bar Padding

Many colors to choose from, and very reasonably priced. #LON 657x (specify color) **\$4.95**



Pit Apron

Tired of ruining clothes on work nights? This is the best way. Hang it up at the shop when the night is over for the next week! #SIM 39035 **\$22.95**

I'M ADJUSTABLE!

Simpson built by Gavin **\$229.99**



A cup holder for me, too!

Child Booster Car Seat

"Just like Dad's!" Big Seller! Favorite among racers with families! #SIM 90000 **\$149.95**

Impact Kids Suit

SFI 3.2A-5 Approved
Designed with the same fabric and options as the Racer Suit with built in arm restraints! Suit comes stock with 360 arm gussets, ribbed arm and ankle cuffs and a tapered collar. The best kids suit TODAY!

Sizes S-XL
\$299.99 **NEW!**



Ultrashield Small Adult Lightweight Halo

Constructed from .100" or .080" Grade 5052 Aluminum. This seat is constructed similar to the adult Lightweight Halo. This seat is designed to fit drivers between the Junior and Adult racers. Halo is padded on back and sides with high density impact absorbing foam for added support and protection. Comes Standard with a 2" shorter Left Side Halo than standard adult seats. Great for mini sprints!
Sizes 11-14 in 1/2 Sizes
\$651.99



NEW!



Child Seats

Very economical seats for the youngsters in 1/4 midgets or micros. Sizes 10-14".

w/ upholstery #KIR 24XXX **\$164.95**
Colors blue, red, black.



Go to page 10 & 11 for more 1/4 midgets & mini sprint seats

Ultrashield Kids Gloves

Finally a glove suited just for kids. Sized just perfectly to fit kids fingers without bunching up. Available in Black, Blue and Red.
#ULT 411xx **\$39.99**



Pyroprotect Kids Single Layer Suit

Simply the best built kids suit on the market today. Durable exterior for kids. Stretch panels for flexibility and room to grow. Kids love them!

Single Layer **\$109.99**
Double Layer **\$299.99**



Simpson JR5 Single and Double Layer Suits

Simpson's new youth racing suits are an exceptional value offered in fire retardant single layer fabric or Nomex single and double layer versions. The basic offers a durable easy to clean finish for parents' convenience with standard cuffs and logo patches on arms and chest. The premium version (pictured) has Simpson logo across chest, straight leg cuffs and inset pockets.

Basic Proban 1 Layer
#SIM STD Y2 **\$99.95**
Premium Proban 1 Layer
#SIM STD P2 **\$139.95**
Premium 1 Layer
#SIM STD P3 **\$209.95**
Basic Nomex 2 Layer
#SIM STD Y4 **\$259.95**
Premium Nomex 2 Layer #SIM STD P4 **\$299.95**



Youth Adrenaline Shoe

Just like his big brother. Wide sole for better pedal grip. Triple layer toe cover and stylish Simpson logos on all sides. Forefoot area is wide and roomy.

Now in kids sizes 1, 2 and 3
#SIM ADOxxx **\$79.95**

Simpson 2" Belts

Available in wrap around or bolt in configurations.

Wrap Around

#SIM 29025x

Bolt In

#SIM 29026x

\$82.95



KIDS SUIT SIZING CHART

Size	Chest	Waist	Hip	Inseam	Neck	Height	Weight
Kids Sm	31-33	24-26	29-31	23	12	4' 1" to 4' 5"	60 to 75
Kids Med	33-36	26-28	31-33	24	13	4' 5" to 5' 0"	75 to 90
Kids Lg.	36-38	29-31	34-36	26	13	5' 0" to 5' 4"	90 to 105
Kids XL	39-41	32-34	38-40	28	14	5' 4" to 5' 6"	105 to 120

TOO MANY WINS TO CHANGE

Introducing the 2010 PMP 600 MINI SPRINTS

Redesigned in 2009 for better corner exit, appearance and cockpit room.

PMP 2010 Deluxe Kit

- >>2010 Down tube Frame w/Left Side Safety Cage and right side horizontal safety bar (new for 09)
- >>2 Piece Fiberglass Hood (new molded naca ducts) w/ Formed Cage Panels (pre-fit)
- >>Complete Set of Aluminum Body Panels (pre-fit)
- >>Dzus Springs & Buttons
- >>W-Link Assembly
- >>8 Torsion Bar Bushings
- >>4 Torsion Stops
- >>(2) 14-1/2"x7/8" Solid Torsion Bars
- >>(2) 26"x7/8" Solid Torsion Bars
- >>Complete Set of Torsion Arms w/4130 Ends (including 2010 bent LR arm)
- >>Complete Set of Stainless Bumpers & 4-Point Knerfs
- >>Complete 2010 Front Axle Assembly with Black Widow or Weld Front Hubs
- >>Complete Rear Axle Assembly including 2010 Birdcages and correct 2010 Spacers
- >>Rack & Pinion Steering Assembly
- >>Swedged Radius Rods w/QA1 Aluminum Rod Ends (steel brake rod with 4130 heim)
- >>Brake & Throttle Pedals w/Hardware
- >>MCP Billet Master Cylinder with steel braided brake line kit
- >>Wilwood 2010 Dynapro Single Brake Caliper with pads
- >>15" PMP Steering Wheel 1-1/8" Outside Diameter
- >>2010 Style Frame Mounted Cross-Flow Radiator w/Cap
- >>Carbon Fiber Air Dam for Radiator
- >>Complete Fuel Tank with **Bladder** and all plates

\$8799.00

This one's COMPLETE!

PMP Complete 600 Mini Sprint

Deluxe Kit + Items Listed Below

- >>4 QA1 Aluminum Body Rebuildable Shocks
- >>Kirkey Seat with Pads
- >>Simpson Latch F/X Seat Belts
- >>2 Weld Direct Mount Front Wheels
- >>2 Weld Magnum Splined Wheels (RR) w/Beadlock & Cover
- >>Complete Top and Nose Wing Mount Set
- >>4 Hoosier Tires
- >>Lightweight Top Wing & Angled Panel Nose Wing
- >>Water Temperature Gauge
- >>Throttle Cable
- >>Gel Cell Battery
- >>R6 Motorplate Kit w/Chain Tensioner
- >>Complete Grade 8 Bolt Kit

\$12999.00<<

PMP 2010 Update Kit

- >>2010 Downtube Frame w/Left Side Safety Cage and right side horizontal safety bar (new for 09)
- >>2 Piece Fiberglass Hood (new molded naca ducts) w/ Formed Cage Panels (pre-fit)
- >>Complete Set of Aluminum Body Panels (pre-fit)
- >>Dzus Springs & Buttons
- >>W-Link Assembly
- >>8 Torsion Bar Bushings
- >>4 Torsion Stops
- >>Complete Set of Torsion Arms (including 2010 bent LR arm)
- >>Complete Set of Stainless Bumpers & 4-Point Knerfs
- >>2010 Front Axle
- >>Set of 2010 Style Rear Birdcages
- >>2010 Style Frame Mounted Cross-Flow Radiator w/Cap
- >>Carbon Fiber Air Dam for Radiator

#PMP CHAUPKIT10

\$4695.00

With 2010 Spindles, Kingpins and Steering Arms

\$4764.99



Offset LR Arm

By offsetting the LR arm the new PMP chassis will have better LR shock angle allowing the car to pivot at corner exit and drive hard of both rear tires.

Expanded Cage

RR corner of upper cage rail is bent to increase elbow room in the cockpit and drive LR corner down in the center of corner when air hits the right side panel.

New Formed Body

The 2009 body is now equipped with molded air ducts and formed around the cage for a sleek and strong appearance. New design also has naca ducts formed into hood to cool the leg area by the engine.

All new Spindle and Steering Arm design

Just like the full size cars with steering arms now coming off of the back of the spindle. Stronger for less flex and better steering feel. New front axle too!

MINI SPRINT

MINI SPRINT



The XXX 600 Mini Sprint Chassis has been designed with the most common dimensions available on the market and we've invested considerable time to make it compatible with most other brands. But don't let the compatibility fool you ... we designed this chassis from the ground up to be better. Entirely constructed of certified and tested 4130 Chromoly Tubing. Whether upgrading your current 600, or starting to build a brand new race car, you'll find this chassis is an all around great performer for all track. Built to accept a well designed adjustable pedal system, easy to use shifter handle, streamline hood and nose, and crossflow radiator. Many different kit combinations to make purchasing an XXX 600 mini sprint simple.



XXX 600 Basic Roller Kit
ONLY \$7895.00!



XXX 600 Racer Kit
ONLY \$2895.00!



XXX 600 Kit B
ONLY \$2195.00!



XXX 600 Deluxe Kit
ONLY \$5775.00!



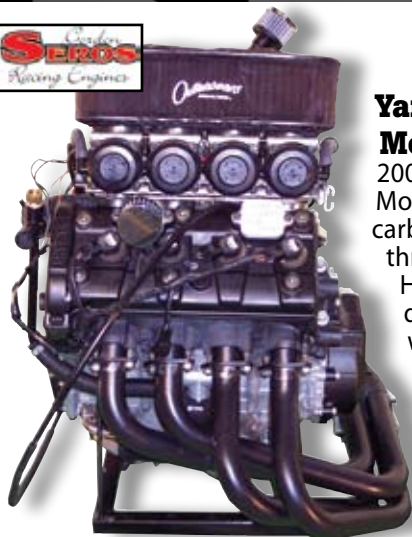

Yamaha R6 600 Mini Sprint Motor

2003-2008 Available. Motors sold complete with header, carbs, airbox, muffler, lowered pan, throttle cable, and all electronics. Hook up three wires, your fuel delivery system and go. Shipped with engine stand. Many options available, call for pricing.



Seros Throttle Position Sensor

The effects of this little sensor going bad are hard start, lazy off of corner, and excessive heat. Many people do not change these and fight fuel or ignition boxes when changing the throttle positioning sensor would cure the problem. #MSE TPS \$112.95



600 Air Cleaner Outerwear

We stock the only nice fitting outerwear to the Seros air cleaner. #OUT 600SER \$29.99

Longacre Switch Panel

Available with engine oil pressure light or without. Contains ignition switch, starter button and fuel pump switch. #LON 44672 \$67.99

Now Coated Switches!



PMP Shifter Arm

Yamaha R6 shifter arm cut to perfect length to fit PMP shifter cable on a 600 mini sprint. #PMP SHIFT ARM \$88.95



600 Mini Sprint Battery

Perfect fit in the PMP Battery Box. A very high performance battery. No maintenance. #MSE BATT \$89.95

Mini Sprint Temperature Gauge Fitting

3/4" Push on adaptor with -12 AN Male threads on other end. Temp gauge swivel fitting on T side. #MSE WLAWT \$37.99

NEW!



600 R6 Restrictors

Legal 3/4" restrictors that install in minutes in the Yamaha R6 Engine. In stock for carbureted engines. Fuel injected restrictors available by special order. #TNT 600RES \$25.99
Fuel Injected #TNT 600RES INJ \$34.99

New PMP Cross Flow Radiator

All 07 and later PMP chassis accept this new cross flow radiator just like the newer sprint cars. Dzuses directly into the chassis and sits perfectly under the hood to accept all of the air the car can grab. 2 Row #SAL CFMSZRW \$339.99
Single #SAL PMPRAD \$319.99
Available with fittings or push-on bungs.



New thicker option for better cooling



Mini Sprint Gas Flush Tank

Completely assembled ready to go gas flush tank for your 600 mini sprint. Hangs on the chassis with the hooks built in and has the shutoffs built right on so it won't leak. Very handy. #HIP 602-210 \$192.99

NEW!



PMP R6 Silver or Black Motor Mount Kit

All the pieces necessary to mount your R6 Engine in your PMP Chassis. Most of the pieces are the same from the Silver to the Black Motor, but please specify when ordering so we can send you everything you need. Complete Kit #PMP K-MMB \$321.95
Complete w/Heims #PMP K-MMBH \$347.95

Saldana Retro Fit Bladder Kit

Designed to retrofit the current 16 gallon shell to the 7 gallon fuel forward tank. Kit comes with foam and bladder to install easily in existing shell. No repainting or changing tail tank mounts to have the latest and greatest fuel tank! Saves 7 pounds full!

#SAL RETRO
\$725.99

NEW!**Holley 600 Fuel Pressure Regulator**

The most common regulator used in the 600 mini sprints.

- 3/8" NPT ports
- .220" (7/32") restriction
- Low Pressure (1-4 PSI)
- Includes mounting bracket
- Chrome Finish

#HOL 12-804 \$35.99

Fuel Injected #HOL 12-803BP \$69.99

Holley Fuel Pump and Regulator Fittings
XRP 981666 \$3.99. Fuel Pump Requires
Quantity 3, Regulator Quantity 2.

Holley 600 Fuel Pump

- Flows 97 GPH (free flow)
- Flows 71 GPH at 4 PSI
- Has externally accessible pressure relief valve (max 7 PSI)

Fuel Pump

#HOL 12-801-1 \$138.99

**Inline Fuel Pressure Gauge Fitting**

-6 male to -6 female an fitting with an 1/8" NPT fitting in the middle to install your fuel pressure gauge inline. Perfect for 600 mini sprints.

#XRP 700195 \$14.99

**Fuel Safe PMP Style Mini Sprint Tank**

Just like the sprint cars, with the nutserts molded in. Sold with or without fuel bladder. Bladder highly recommended for safety with methanol fuels.

Complete: #FUE MB216WM \$1292.99

Shell: #FUE MT116 \$263.99 (no bladder)

Bladder Only: #FUE MB116 \$956.99

**Walbro Injection Fuel Pump**

An economic fuel pump set up for injection systems. Used by teams throughout the country to power their 600 engines.

#HIP 602-106
\$149.99

Fittings

#HYP 602-1065 \$14.99

Requires 2

**Clamp**

#HYP 602-112 \$17.99

**NEW!****Fuel Forward Mini Sprint Tank**

The Fuel Forward Tank Tail is designed to get the fuel weight forward and lower by about 12%. All new design holds 8 gallons of fuel with foam packing in the rear 8" of the tank to keep fuel from sloshing in the corner and keeps fuel lower reducing the impact of fuel load as the race progresses. With the fuel forward and foam in the rear, a safety crush zone is also created in the rear of the tank. The new Fuel Forward Tank Tail has the same mounting points as the Fuel Safe or Saldana Mini Sprint Tanks.

No new mounting required to convert.

#SAL 214FF \$1095.00

**NEW!****Auto Meter Fuel Pressure Gauge**

Available for injection systems (0-100psi) or for carburetors (0-15) with 1/8 npt male fitting on backside.

#ATM 2172 (0-15)

\$36.99

#ATM 2174 (0-100)

\$36.99

**R6 Carburetor T Fitting**

Stainless T with AN threads to adapt fuel lines to engine instead of plastic OEM T.

#MSE CARBTS \$19.99

NEW!**Mini Sprint Tail Tank Cover**

Keep your fuel cool while sitting in the pits.

#CRV 16CVR \$69.95



R6 Engine Sprocket Nut

#MSE SPRNUT
\$11.99



R6 Engine Safety Washer

#MSE SPRWSHR
\$5.99



R6 Upper Motor Mount

Required to adjust chain tension on PMP and XXX Mini Sprints. 4 1/2" long. Keep one in tool box for a spare!
#PMP MMUP
\$15.99



PMP Throttle Cable R6 Engine

#PMP THCBLE
\$29.99



PMP Shifter Handle with Clutch Lever

Billet aluminum handle for PMP cars that bolts right in to the mounts provided on all late model 600 cars. Complete with clutch lever.
#PMP SHHNDL
\$101.99



PMP Shifter Cable R6 Engine

#PMP SHCABLE
\$101.99

PMP Throttle Cable Shaft Collars

Split Collar #PMP THCSC
\$4.99
1 Piece #PMP THCOP
\$3.99



PMP Splined Sprocket Hub

Super light, but very strong.
#PMP SPRHUB
\$58.99

Silkolene Pro Chain Lube

The cleanest, longest lasting chain lube we have found. 100% synthetic non-fling racing chain lubricant. A clear, clean product with excellent anti-wear characteristics.
#SMI CHNLBE \$13.95



ERT 520 Chain

The best chain for your 600 Mini Sprint. High quality chain controls stretch, and prevents chain slipping. Long enough for today's car configurations.
#MSE CHN130 \$126.99
#TRX-600-DL-0001
\$109.99

Crankcase Vent

Fits on the crankcase vent tube to prevent dirt from getting into engine and oil from spraying on driver from crankcase expansion.
#KNE 62-1320
\$17.99



11-14 Tooth Counter Sprockets

#PMP SPR1x \$27.99
(specify tooth count)

ERT 520 Rivet Link

#MSE RVTLNK \$4.99



ERT Chain Riveting Tool

Every team should have one. Master links are a thing of the past. This tool is the easy, smart way to assemble your chain.
#MSE RVT \$109.99



Roller Wheels Separate

#PMP CHNRLLR \$36.99



PMP Clutch Cable R6 Engine

#PMP CLCAB \$36.99



PMP Chain Guide System

NO better chain roller system available. Bearings in each roller, and designed to float with natural chain motion.
#PMP CHNTASS
\$93.99



PMP Front Axles

Available in 03 and 04. Coil or Torsion Bar configuration. We'll help you figure out which one you have.

04+ Torsion Bar Non-Plated

#PMP FA04 \$139.95

Coil Non-Plated

#PMP FA04C \$149.95

04+ Coil #PMP FA04CP \$160.00

**3/8" Tall Cone Spacers**

1 required to assemble a front axle.
2 pack #PMP FASPCL-2 \$7.99

**3/8" Short Cone Spacers**

You always need these for something. 2 are required to assemble a front axle.

We've got them in single or multi packs.

4 Pack #PMP FAPCSHT-4 \$7.95

**XXX Mini Sprint Steel Tie Rod**

Tired of bending tie rods? XXX built a steel tie rod just like the sprint cars. Requires 3/8" steel heim.

#TRX 600-SU-0182
\$26.99

**XXX Complete Mini Sprint Front Axle**

Keiser hubs, XXX plated front axle, steering arms, spindles, kingpins, tie rod, steel heims with jam nuts. Hardware sold separately. Fits XXX and PMP chassis.

#TRX 600-FE-9023
\$559.99

PMP Complete Front Axle

PMP front axle, Weld mini sprint hubs or DMI Black Widow Hubs, PMP spindles, steering arms and kingpins, polished aluminum tie rod, QA1 aluminum heims, all spacers, bolts and thrust kits included. 2009 version available with new style axle, spindles, and steering arms.

#PMP FACMPBW \$599.99

2009 version #A-FACMPBW09 \$659.99



SUBSTITUTE ANY HUBS TO CUSTOMIZE YOUR FRONT END!

(Extra charge may apply)

NOW AVAILABLE IN BLACK**XXX 600 Torsion Bar or Coil Front Axle**

600 Mini-Sprint Front Axle. 1 1/2" X .120 Wall 4130 Chrome Moly. Chrome Plated. Jig built for exacting quality and fit. A really great looking and finished piece.

Torsion Bar: #TRX 600-FA-0002 \$95.00

Coil: #TRX 600-FA-0003 \$95.00

**PMP Thrust Bearing Kit**

All the shims you need to set up your front axle.

#PMP KPTBKT \$7.99

(each side)

**PMP Kingpin Set**

We've got them in stock in steel or titanium tubular kingpins. Clips provided to hold them in and groove milled for set screw.

Steel #PMP KPS \$39.99 Kit

Titanium #PMP KPT \$49.95 ea.

09 #PMP KPS 09 \$43.99



WELD RACING **NEW!**

Weld Mini Sprint 3 Spoke Lightweight Hub

The lightest mini sprint hub ever! Built by the standard in the wheel industry, Weld Racing. 3 even points of contact for the ultimate in strength and the best way to reduce rotating weight on the front end of your car. SAVES 1 lb. per side!
\$147.99 ea.

JOES 4 Spoke Mini Sprint Front Hub

JOES mini sprint front hubs are thick where you need it and thin where you don't for a strong yet lightweight hub package. The LF hub includes a rotor mounting flange. JOES hubs are precision machined to run true. Anodized black and laser etched JOES logos for a clean look on your mini. Only 1.94 pounds.
#JOE 25605 LF \$135.99
#JOE 25610 RF \$129.99



NEW!



Black Widow Mini Sprint Hub Set

Built with the same construction as the sprint car version. Anodized black and very light. Pressed in bearings and upgraded studs.
#DMI LRC-1972B \$219.95



JOES Split Nut

Tired of using plastic nyloc nuts to hold on your hubs on your 600? JOES mini sprint hub split nut utilizes a cinch bolt system to securely lock down your hub at any torque setting.
#JOE 25601 \$15.99

NEW!



Keiser Mini Sprint Hubs

Need some economy front hubs for your 600 mini sprint? Keiser 10" Front Hubs are your answer. Plated finish.
#KEI DLIOxx \$95.99

XXX Mini Sprint Steering Arms

Left Front
#XXX 600-FA-0010 \$19.99
Right Front
#XXX 600-FA-0011 \$19.99



PMP Steering Arm

Built so it can be run on left or right side. We've never seen one break! Super strong.
#PMP STEER ARM \$26.99
New Style #PMP ST ARM09 \$27.99



2003-2008

NEW STYLE

Mini Sprint Spindle Bearing

Not an easy bearing to lube, so they go bad at least once a year. A great winter project to change them out.
#FAS BR-1641RR \$4.95



PMP Spindles

Machined perfectly to accept PMP steering arms with recessed allen head bolts and zerc fittings installed stock. Tephlon bushings make the kingpins a perfect fit.
#PMP SPINx (specify left or right) \$79.99
New Style #DMI LRC-2000 \$109.99



New Setup

XXX Mini Sprint Spindles

Right #XXX 600-FA-0008 \$69.99
Left #XXX 600-FA-0009 \$69.99

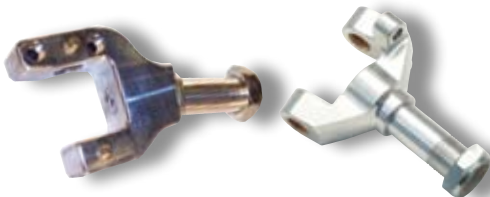



PMP Complete Rear Axle

Complete with all necessary spacers, axle nuts, cones, birdcages, brake carrier, splined sprocket and brake hubs.

04-06: #PMP RACOMP \$1069.99

07: #PMP RACOMP 07 \$1069.99

Bare Rear Axle: #PMP RAXLE \$295.99



PMP Rear Axle Nuts

The perfect size for PMP Axles. Different mini sprint brands use different size axle nuts so be sure you have the right size.

#PMP RANUTx \$24.95

Forward Bite Birdcages

PMP narrowed up the pickup points on their cages to increase the grip at the rear tires.

As the cage rotates the chassis will react quicker with these new anodized black cages. Fits 07-10 PMP Chassis.

#PMP BCSET07 \$339.95



PMP Watts Link Straps

Fits all of PMP Jacobs Ladders from 2000 on up. Lightened and precision drilled. Sold in packs of 4.

#PMP WLSTRP-4 \$15.95

XXX 600 Watts Link with Straps

10 1/4" Jacob Ladder complete with straps. Chrome plated. Jig built for quality and exact fit.

#TRX 600-SU-0002 \$29.99



Rear Sprockets

We stock rear sprockets to fit PMP's hub from 49-54 teeth. High quality aluminum for strength and longevity.

#MSE SPRxx \$53.99



PMP Bird Cage Inserts

Splined Inserts for PMP Birdcages and Brake Carriers

Brake Carrier: #PMP BCI \$16.99

Birdcages: #PMP BCIL \$18.99



PMP Splined Sprocket Hub

Super light, but very strong.

#PMP SPRHUB \$58.95



3/4" Coned Spacer

#PMP SPC34T

\$15.95

1" Coned Spacer

#PMP SPC1T

\$17.95



PMP Spacer Kits

We've got them in stock for 03 or 04 chassis. Complete kit of all of the spacers you will need inside of the cages and out by the wheels.

#PMP SPCKT04 \$67.95

Anodized Black

#PMP SPCKTBK \$67.95

PMP 600 Birdcages

Designed specifically for PMP. We stock them in 00-03 cars and 04+. Complete with bearings installed, and all bolts supplied.

#PMP BCxx04 (specify side)

\$169.95

#PMP BCxx03 (specify side)

\$149.95

Inserts sold separately



600 Mini Sprint Birdcage Bearings

Bearings in stock for brake bracket, LR, and RR Birdcage.

Brake #FAS 6010-2RS \$22.95

Birdcages and 09 Brake Carrier

#FAS D6010-2RS \$38.95



PMP Complete Watts Link

Perfect geometry for your PMP 600 Mini Sprint. We carry them assembled or in separate pieces.

Kit: #PMP WLKIT \$64.95

Key only: #PMP WLO4

\$47.95

Straps only: #PMP WLSTRP-4

\$15.95



Mini Sprint Torsion Bars

Available in solid or hollow. We stock the following bars.

600 Long Bars
7/8" x 26"
.675 Solid
.700 Solid or Hollow
.725 Solid or Hollow
.750 Solid or Hollow

Solid \$77.50
Hollow \$97.50

600 Short Bars 1200 Long Bars
14.5" x 7/8" 1" x 28"
.525 Solid .725 Solid or Hollow
.550 Solid .750 Solid or Hollow
.575 Solid .775 Solid or Hollow
.600 Solid .800 Solid or Hollow
.625 Solid .825 Solid or Hollow
.850 Solid or Hollow

Solid \$77.50
Hollow \$97.50

PMP Aluminum Rear Torsion Arms

Right rear measures 13" and has an offset of 4". Left rear is 11 1/2" and is straight. Both are splined for 7/8" torsion bars.

#PMP ARR \$52.95
#PMP ARL \$46.95

XXX Mini Sprint Front Arms

Same measurements as other major brands. Compare the price!

LF #TRX 600-SU-0171 \$39.99
RF #TRX 600-SU-0172 \$39.99

XXX Mini Sprint Rear Arms

Fits XXX and other major chassis brands. Compare the price!

LR #TRX 600-SU-0173 \$48.99
RR #TRX 600-SU-0174 \$48.99

PMP Aluminum Front Torsion Arms

Sold as left or right front. Left front measures 13 1/2". Right front measures 12". Splined for 7/8" torsion bars.

#PMP ALF \$46.95
#PMP ARF \$46.95

King Mini Sprint Torsion Bar Reamer

The best torsion bar reamer on the market. Complete with all tools needed to align your torsion bar bushings perfectly. 3/4" hex socket built right in for your impact gun. A little WD-40, a 3/4" socket, 8 bushings, and you are in business!

#KRP 2500 \$178.99

PMP Aluminum Torsion Stop

High quality aluminum stop strong enough to use on all 4 corners of the car. 7/8" splines.

#PMP TS 600 \$29.95

PMP 7/8" Brass Torsion Bar Bushings

A good idea to replace each spring or when bars get stiff as the chassis starts to wear.

#PMP TBBUSH \$7.95

Rear Arm and Steel Brake Rod Heims

- Chrome Moly Steel
- Heat treated
- Protective coated for corrosion resistance

Right: #QA1 XMR7 \$11.85
Nut: #QA1 JNR7 \$.95
Left: #QA1 XML7 \$11.85
Nut: #QA1 JNL7 \$.95

JOES Steering Wheel Tape

Stops your hands from slipping on the wheel and keeps gloves from ripping.

#JOE13600 \$6.99

Mini Sprint Steering Hub

For older cars without a solid steering mount on shaft. Welds onto 3/4" shaft. Push button release.

#LON 56600 \$29.95

PMP Steering Wheel

All new 1 1/8" diameter dished steering wheel for the PMP 600 mini sprints. CNC drilled and embossed with PMP logo. Anodized black.

#JOE PMPSW \$82.95

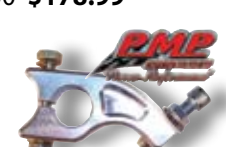
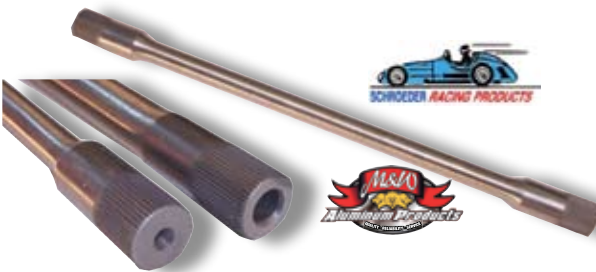



Polished Hi Strength Aluminum Mini Sprint Rods

Threaded 7/16" or 3/8". We stock 12 1/2", 14", 14 1/2", 15", 19 1/2", 20", and 21". Just specify which year of PMP Chassis you have, what corner of the car it came from and we'll do the rest. Tie rod and drag links in stock, too.

Short rods \$11.99
Long rods \$20.99

PMP Complete Radius Rod Kit

Includes all 18 heims and all 9 rods to completely suspend a PMP Chassis. All Aluminum QA1 Heims, Polished Radius Rods and Aluminum Jam Nuts. A Great Value!!!!



04-06 Complete Kit w/Steel Brake Rod & Heims \$299.95
07 Complete Kit w/ Steel Brake Rod & Heims \$299.95
08 Complete Kit w/ Steel Brake Rod & Heims \$299.95
09-10 Complete Kit w/ Steel Brake Rod & Heims \$299.95
#PMP K-RR0x (please specify year)



QA1 Mini Sprint Heims

The highest quality heim built. We stock um all! Below are standard heims on all of our PMP cars.

7/16" Aluminum (Rear of car)

\$11.95

7/16" x 3/8" (Front of car)

\$11.95

3/8" Chromeoly (RR Birdcage to Watts Link) \$11.95

Specify left or right hand threads when ordering.



4130 Brake Rod Heims

- Chrome Moly Steel
 - Heat treated
 - Protective coated for corrosion resistance
- Right: #QA1 XMR7 \$11.95
Nut: #QA1 JNR7 \$.95
Left: #QA1 XML7 \$11.95
Nut: #QA1 JNL7 \$.95

Steel Mini Sprint Heims

3/8" or 7/16" available.

Mild Steel

3/8" #QA1 CMx6 \$4.95

7/16" #QA1 CMx7 \$6.95

Upgraded Steel (Black)

3/8" #RDE MMx6B \$5.99

7/16" #RDE MMx7B \$7.99



PMP Complete Titanium Bolt Kit

All of the bolts you need to assemble your PMP 600 Mini Sprint. Wing, knerfs, rods, shocks, arms, stops, front end, and tail tank! Make your car the lightest out there!
#MET A-PMPTIKT \$899.99



PMP Steel Brake Rod

Replaces the aluminum brake rod on PMP 600 Mini Sprints. The aluminums will bend with heavy braking and often snap in a crash. Made from 4130 steel and powder coated black.
#PMP RRSBR \$29.95

PMP Titanium Radius Rod and Shock Quick Pin Kits

BRAND NEW!!! Finally a kit for the mini sprints. The complete radius rod kit comes with 9 studs and attaches all of the rods to the car and the front axle. The shock kit comes with 8 pins to attach shocks at all points on car. Shock kits can be purchased with quick pins or one nut style.



Shock Kit-One Nut or Pin Style \$135.99

PMP RADIUS ROD LENGTHS				
	2003	2004	2007	2008-10
LF	12 1/2	14 1/2	15 1/2	15 1/2
RF Top	14	14 1/2	15 1/2	15 1/2
RF Bottom	14 1/2	14 1/2	15 1/2	15 1/2
Drag Link	14 1/2	14 1/2	14 1/2	14 1/2
Panhard	15 1/2	15 1/2	15 1/2	15 1/2
Tie Rod	37 1/2	36 1/2	36 1/2	36 1/2
LR Rod	19 3/4	20	20	16 1/4
Brake	19 3/4	20	20 Steel	20 Steel
RR	20 1/2	21	21	17 1/4

PMP Complete Bolt Kit

These cars take some special bolts that are machined, so it is important to have spare bolts for everything in the car. Handy tote allows you to keep one complete in the pits for emergencies or to build a brand new car.
#PMP BLTKIT \$105.95



Mini Sprint Master Cylinder Remote Reservoir Kit

Tired of the brakes fading on your 600? Most times this is caused by the small reservoir in the 600 master cylinder. A raised remote reservoir will solve this problem. Just simply install this kit and add more fluid and your problems are over.
#PMP K-MSBRKRES \$56.99



NEW!

Wilwood Sprint Style Master Cylinder

For those with adjustable pedal setups or the patience to build your own brake setup for your mini sprint, we offer the Wilwood Mini master cylinder. Large reservoir attached for less brake fade and lighter than the sprint version.
#WIL 260-10374 \$81.99



NEW!

NEW Larger Piston 600 Master Cylinder

7/8" Bore master cylinder allows more volume of fluid to hit the calipers at one time giving tons more braking power! Cast design for cooling.
#PMP MA15875 \$99.95
Standard Bore
#PMP MASCYL \$79.95



PMP Front Brake Pads
#PMP BPFRT \$27.95 pr.

PMP LF Brake Caliper

Proven to add tons more stopping power.
#PMP LF CAL \$126.99



Red Devil 4 Piston Mini Sprint Caliper

Red Devil quality for your mini sprint! 4 piston with center posts to stop brake fade due to o-ring failure. Mounts on a 3 1/2" bolt centerline, so our special brake carrier is required. Match this with the Red Devil Titanium Rotor and you will have the best stopping power available!
\$295.00



NEW!



Wilwood Mini Sprint Rear Caliper

Billet Aluminum with internal crossover for maximum brake.
#WIL 120-10188 \$99.99

PMP Double Bearing Brake Carrier

Complete Brake Caliper Mount for the rear of the PMP Mini Sprint. Assembled with bearing and all bolts.
#PMP BCARDS \$94.95



New Style Red Devil Brake Carrier



NEW!

With the new Red Devil Titanium Rotors, the mini sprints put too much demand on the caliper to have any longevity. Red Devil builds the best and longest lasting calipers that hold up to heat. We have now come up with a mount that will adapt to both the rotor and the caliper for a matched piece!
THE BEST BRAKES YOU CAN BUY FOR YOUR 600.
#PMP BRKRDC \$189.99

Red Devil Ultimate Mini Sprint Titanium Brake Kit

FINALLY, a brake system that STOPS for your PMP or XXX 600! Complete-bolt on system built for you by the folks at SpeedMart. Rotor weighs only 11lb 2oz. Brake Caliper has center posts inside of standard pistons for added heat protection. Pads are the most aggressive in the business. Brake Carrier is a different height, so this one is required to have system fit your car.
#RED K-MSBRK \$949.00



NEW!



Steel Rotor Inboard Pad

Long lasting and best pad for stopping power on steel rotors.
#WIL 15B-9819 \$15.95



NEW!

Red Devil Ti 600 pad

Built specifically for the Red Devil Ti Rotor with the PMP brake carrier. Pad material installed at correct height for awesome stopping power!
\$26.99

**PMP LF Brake Kit**

Sold with rotor, caliper, pads, and mount. Easy to put on. Evens out your brake system and allows LF to pull down in corner and pivot around apex when brakes are applied.

#PMP K-LFB \$199.99

**XXX Mini Sprint Brake Hub**

Built with same dimensions as other major brands. Compare this price!

TRX 600-SU-0181 \$53.99

**PMP Splined Brake Hub**

Adapts steel or titanium rotor to rear axle. All hardware included.

#PMP BHUB \$57.95

Brakeman Mini Sprint Brake Kit

Tired of not stopping with your 600? Brakeman has a kit that will put an end to the stopping difficulties for good. Redesigned caliper with bigger pads and a thicker rotor for longevity and the great stopping power that Brakeman is known for. Mounts to existing PMP or XXX splined rear hub. Rotor measures 9 1/2".



Kit Complete #BRA
K-600 \$347.99

Rotor Only #BRA
1038 \$125.99

**JOES Splined Brake Hub**

JOES Mini Sprint Rear Rotor Carriers are fully radiused and pocketed for maximum weight savings and strength. Precision splines keeps your JOES parts spinning true for the ultimate in performance.

#JOE 25685 \$59.99

NEW!

PMP LF Brake Rotor

Mounts directly to JOES, Weld and DMI mini sprint hubs.

#PMP FB RTR \$52.99

**New Style LF Brake Bracket**

Built for the sprint car style spindles. Simply split the LF caliper and install this plated bracket. Fits Hyper and PMP spindles.

#HYP 366-2985

\$21.99

JOES Mini Sprint Front Rotor

For the left front of your 600. Made from 1018 steel. Fits JOES, Weld and DMI hubs. Cooling slots help dissipate heat and the scalloped shape saves weight without sacrificing braking. JOES rotors are designed to stand up to the heat for consistent braking throughout the race.

\$45.99

**Red Devil Mini Sprint Coated Titanium Rotor**

The best rotors in the racing industry are now built for PMP 600 Mini Sprints! Patented coating on a lightweight titanium rotor for the best stopping power you can buy. Red Devil Rotors are used by all of your top sprint car teams, and now we've got one for the 600's! Weighs only 1 lb. 2 oz.

#RED MSRTR \$449.95

**JOES Mini Sprint Rear Rotor**

Made from 1018 steel. Cooling slots help dissipate heat and the scalloped shape saves weight without sacrificing braking. JOES rotors are designed to stand up to the heat for consistent braking throughout the race.

\$49.99

NEW!

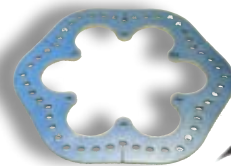
**PMP Steel Inboard Brake Rotor**

Fits on stock PMP splined brake hub.

#PMP BRREAR \$47.99

Afco Double Adjustable Sprint/Mini Sprint Shock

The M2's ability to keep the tires in compliance with any track surface condition from tacky to slick, bumpy to smooth, rutted to washboard, lies in its combination of low friction and fast reacting components. Working together, all the parts of the M2 provide unparalleled seat-of-the-pants feel for the track, consistency, and TRACTION.

Flexible Gas Bladder Design

The M2's gas inflated bladder is able to compress and expand at incomparably high speeds, very slow speeds, very small movements and large deflection all at the same time with virtually no resistance or friction. This allows it to react to the most minute high frequency chatter, while still providing positive control of weight transfer during transitions on the track.

Adjustment Range

The M2's design allows it to perform in ways other shocks cannot. The M2 provides an unparalleled range of adjustment & performance abilities. Due to its unique design, the adjustments you make with the M2 have a very large effect on handling.

The M2's mono-tube, gas pressure design coupled with its superior valve design and use of gas charged bladder provide real, substantial control of compression and rebound resistances throughout the entire velocity range. This means the M2's adjustments are much more pronounced and provide more sensitive & extended low speed adjustments for increased effective tuning range.

Low Gas Pressure

The M2 remains hyper-sensitive at significantly lower gas pressures than the competition. This gives you the advantage of being able to run a MONO-TUBE shock and achieve TWIN-TUBE shock feel & characteristics.

Easy To Use & Accurate

The adjusters on the AFco M2 are specifically designed to make fast, precise, and repeatable changes. The knobs are 100% O-ring sealed from the elements and easy to grasp, even with muddy, greasy, or gloved hands. The easy-to-feel, spring-loaded detents allow you to quickly change with a simple click.

NEW!

THE ULTIMATE WEAPON

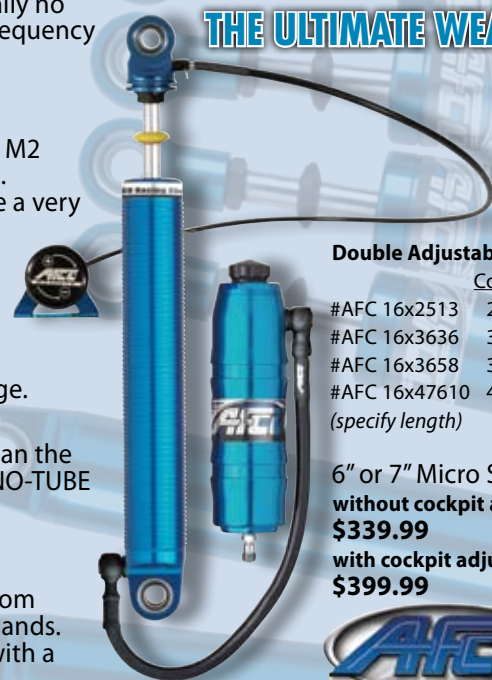

Double Adjustable Ranges

	Comp	Reb
#AFC 16x2513	2-5	1-3
#AFC 16x3636	3-6	3-6
#AFC 16x3658	3-6	5-8
#AFC 16x47610	4-7	6-10

(specify length)

6" or 7" Micro Shock
 without cockpit adjuster
\$339.99
 with cockpit adjuster
\$399.99



Afco Edge Complete Shock Packages

NEW! EDGE Sprint Car/Mini Sprint Packages - (Now available in 6" & 8" Packages, as well as 7" & 9")

NEW!

Winning reputations aren't given – they're earned. Tireless testing and development have earned AFco a reputation for offering the best-performing Sprint Car shock line on the track, with multiple championships in USAC and the World Of Outlaws as a result. Now, with the help of many champion drivers, AFco has developed an all-new line of EDGE Sprint Car/Mini Sprint Packages, available now!

The EDGE Sprint/Mini Sprint Packages are more than just boxes of shocks. Each of the 11 shocks in these packages is designed to provide specific rebound and compression dampening at both low- and high-speed shaft velocities to maximize handling for specific track conditions. Each package also includes a comprehensive tuning guide that shows you exactly which shocks go together to make all four corners of your car perfect for any track condition – whether it's dry, slick, heavy or rough.



The EDGE Sprint Car/Mini Sprint Packages provide you the complete arsenal to dominate any track condition. AFco also offers four-shock Slick Track Only packages. If you want to take the guesswork out of your shock setup, the new line of AFco EDGE shocks is your answer.

Applications:

- Sprint Car/Mini Sprint (Wing and Non-Wing)
- Fully rebuildable shocks

MINI SPRINT PACKAGES

11-Shock Package, Wing/Non-Wing (6")
\$1759.99
 (only \$159.99 per shock!)

EDGE VALVE



QA1 Aluminum Mini Sprint Shocks

The most economical shock to have on your mini sprint is the QA1. The shocks are precision built for repeatability, they don't fade, and the valving stays consistent throughout their life span. QA1's can be mounted in any direction and have ribbed exteriors for superior cooling. The shocks are completely owner re-valveable and Re-buildable. All of the parts are available to rebuild them if you damage them in any way.

#QA1 826x **\$167.99**

Recommended valvings for a PMP are
LF 8262 RF 8262-1
LR 8262-4 RR 8264

**Advanced Racing Adjustable Mini Sprint Shock**

The Advanced Racing Adjustable Series shock is superior to any small body twin-tube shock on the market. The ARS shock uses CNC machined aluminum internal parts designed for racing with no aftermarket parts. SpeedMart stocks adjustable front shocks for 600 mini sprints in a 2 compression with .5 to 4 on rebound for the right and left front. This allows the crew chief to put a riser shock on both corners but have the left front tied down more than the right. For the rear we stock a 2 compression with a 2-8 rebound for both rear corners. This allows the car to be tied down in the rear end and a crew chief can adjust the rebound on a red flag quickly as the track dries.

#E106x-x/x **\$350.00****AUTHORIZED AFco REBUILDER**

SpeedMart is proud to announce the convenience of rebuilding your Afco shocks!

We will be sending our staff back to Afco to be trained

to produce the perfect Afco shock every time. Stay tuned as we add this feature to our already full service speed shop!

**PMP Mini Sprint Shock Bushings**

Since the mini sprints have 3/8" shock spuds on the chassis, it is important to have extra bushings in your tool cart. Without them, your shocks will not work on the car. Sold in packages of 8.

#PMP SHKBSH **\$6.95****Pro Rebound Adjustable Shocks**

Pro Shocks rebound adjustable shock is unique and user friendly. Adjustable on rebound, without effecting the compression control. Easy to adjust by inserting a 3/16" allen wrench into the rebound adjuster screw. Allen screw has an index pin, just align this pin with the stamped rebound number. A great way to fine tune your car without changing shocks.

#PRO SBA-xxx **\$249.99****Afco Small Body Shocks**

AFco small body aluminum shocks have proven to be winners all over the country. So Afco went to work redesigning their aluminum small body. This shock provides the advantage you have been looking for and the consistency any racer needs. Superior feel with a valving curve that allows for the driver to have direct connection to what the car is doing. Many other shocks will fall off as the car travels at increased speeds. Afco Small Bodies maintain their feel throughout the shock curve.

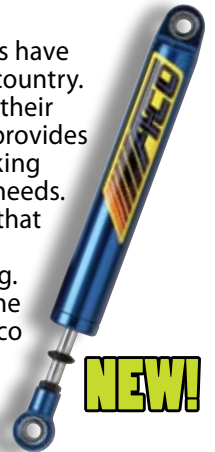
#AFC 16xx **\$156.99****Small Body Tuning Kit**

For 70 and 82 Series Shocks
Tuning kit contains:

- O-rings, seals, wipers
- Assortment of deflective discs
- Easy-to-follow instructions

#QA1 TK02 **\$144.95****JOES Small Body Shock Wrench**

Perfect for working on your shocks. One wrench takes the whole shock apart!

#JOE 19085 **\$48.99****Carbon Fiber Shock Protectors**

Very easy to attach to either small or big body shocks. Keeps your shocks looking brand new.

#FTC CFSC **\$20.00 ea.****Kirkey Heavy Duty Shock Covers**

Keep the mud out of your coil springs and look good at the same time! We stock these shock covers in red, black, and blue.

#KIR 005x **\$25.99**

TIRES & WHEELS

MINI SPRINT

NEW!



Keiser Mini Sprint Wheels

The best value in mini sprint wheels. All Keiser wheels are CNC cold spun and are double heat treated for unmatched strength. Centers are cold forged billet. Great strength to weight ratios, and for the money, you can't beat this value.

- Front Rimshell 3 or 4" offset \$86.99
- LR wheel complete 3" or 4" offset
- 10 x 9 Non-Beadlock \$157.99 Beadlock \$239.99
- 10 x 10 Non-Beadlock \$157.99 Beadlock \$241.99
- RR wheel complete with Mudcover 4, 5, and 6" offsets
- 10 x 10 \$266.99
- 10 x 12 \$285.99
- Mudcover only \$25.99



Weld 600 Wheels

The strongest, lightest mini sprint wheel made!

Direct Mount Fronts



(Rimshell or bolt together. Beadlock & non beadlock)

LF 10x7 3" Offset #WEL 860-10713 **\$93.95**

RF 10x7 4" Offset #WEL 860-10714 **\$93.95**

RF 10x7 4" Offset Beadlock w/ Cover

#WEL 860-10754 **\$217.95**

Splined Rears



LR 10 x 9 4" Offset Outer Beadlock

#WEL 734-10924 **\$294.95**

LF 10 x 10 4" Offset Outer Beadlock

#WEL 734-11024 **\$300.95**

RR 10 x 12 5" Offset Outer Beadlock w/ Full Cover

#WEL 734-11255 **\$317.95**



Front Rimshell



Left Rear



Right Rear w/Cover



Wheel Halves in Stock

3", 4", 5" No Lock

4", 5" w/ Lock

5", 6", 7" W/ Full B/L & Cover

PMP 600

Wheel Wrench

Fits PMP axle nuts perfectly with great leverage. The only one out there.

#SAL WW-MS **\$131.99**



600 CARS



MIDGET / 1200 CARS

Front

57/6.0-10 D10/D12/D15

Left Rear

61/10.0-10 D10/RD12/RD15

62/10.0-10 D10/RD12

63/10.0-10 D10/RD12/RD15

64/10.0-10 D10/RD12/RD15

63/8.0-10/RD12

64/8.0-10/RD12

Right Rear

69/10.0-10 RD15/D30

69/10.0-10W RD15/D30

Front

68/7.0-13 D12/D15

Left Rear

74/10.0-13 D10/D12

72/10.0-13 D10/RD12/D12

76/10.0-13 Focus

74/10.0-13 Focus

Right Rear

82/12.0-13 SP-2

80/10.0-0-13 Focus

78/10.0-13 Focus/D12

Mini Sprint Titanium Beadlock and Wheel Center Bolts

Save rotating weight with replacement titanium bolts for the beadlock and wheel center of your wheels. Complete kits in stock!

Center #AST 5407KIT

\$59.99

Beadlock

#AST

4407KIT

\$49.99

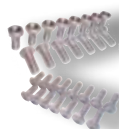

Conroy 600 Mini Sprint Diaphragm Bleeder Set

The mini bleeder is designed to fit an axle bore of 1.062 (1 1/16in), such as the Bailey and PMP chassis. Also included is a bleeder extraction tool to help remove the bleeder from the axle.

#CON MS

\$329.99

NEW!



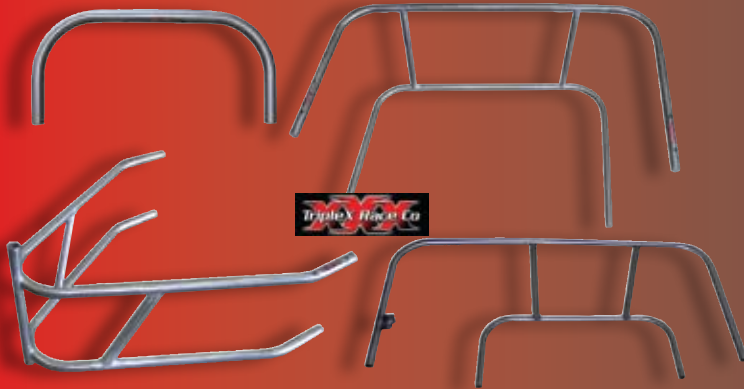

XXX Complete 600 Knerf Set

Complete bumper and knerf package. All pieces are Stainless steel and polished to perfection. Each piece is CNC bent and jig built for quality and exact fit. Fits most 600 mini sprint chassis.

#TRX 600-BN-1000 \$219.99

PMP 600 Rear Bumper

#PMP RB04 \$100.00
#PMP RB03 \$100.00



PMP Knerfs Left Side Knerf \$90.00

Right Side Knerf
\$100.00



PMP Front Bumpers

03, and 04 in stock!
03 (also fits PMP 250 cars)
#PMP FB 04 \$20.00



XXX 600 Rear Bumper

Stainless steel rear bumper without basket. Polished to perfection. CNC bent and jig built for quality and exact fit. Fits most 600 chassis.

#TRX 600-BN-0005 \$73.00



XXX 600 Left Side Knerf

Stainless steel left knerf bar. With dzus tab for chain guard. Polished to perfection. CNC bent and jig built for quality and exact fit. Fits most 600 chassis.

#TRX 600-BN-0002 \$66.00



Mini Sprint Dzus Buttons

Used for 1/4 midgets, & most mini & micro sprints. Hard to find! 10 packs.

DZU MSA \$12.99

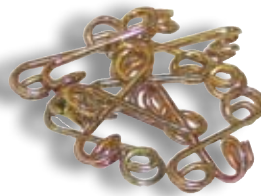

Mini Sprint Dzus Springs

Specially sized to fit the mini sprint dzus tabs. Smaller than the standard springs used on sprint cars. Sold in packages of 10.

#DZU MSSPR \$8.99

XXX 600 Front Bumper

Stainless steel right knerf bar. Polished to perfection. CNC bent and jig built for quality and exact fit. Fits most 600 chassis.

#TRX 600-BN-0010 \$11.00



XXX 600 Right Side Knerf

Stainless steel right knerf bar. Polished to perfection. CNC bent and jig built for quality and exact fit.

Fits most 600 chassis.

#TRX 600-BN-0001 \$72.00

600 Top Wing

Very strong internal slider top wings for PMP 600 cars. Designed to slide 1" farther back than standard wings for increased traction. Very straight and precise engineering. Fits all standard PMP wing tees and posts. Sold FULLY ASSEMBLED or panels off.

Extended Panel
#LMW TW600LW
\$369.95
Panels Off
#PMP TWD54
\$445.00



6 lbs lighter!

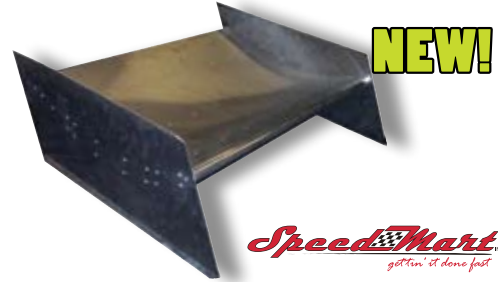

NEW!



600 Nose Wing

Just like the PMP nose wing, except a little stronger. Side boards will not come loose like other wings, and aren't easily bent over. Tons of car owners have switched to these. Available for coil and torsion bar cars.

#LMW NWTBA **\$100.00**



XXX 600 Top Rear Wing Tee

Top wing tee. Complete with internal sliders. Chrome plated 4130 Chrome Moly. 1" adjustment holes, with a total of 6" of adjustment.

#TRX 600-TW-0002 **\$55.00**



PMP Complete Rear Wing Tee

We stock 00-03 and 04+ versions for your convenience. Adjusters sold separately also.

#PMP K-WT04 **\$69.95**
Adjusters (Separate)
#PMP WTADJS **\$29.95 (Pair)**

Mini Sprint Wing Caps

Fits the 600 top wings perfectly.
#ARO MS **\$50.00**



PMP Nose Wing Strap Set

Lots of holes for front wing adjustment. Takes a 1/4" bolt in the top and drilled for 5/16 dzuses in bottom.

#PMP NWUS **\$12.95**



XXX 600 Manual Wing Slider

Top wing manual slider (adjuster). Complete without pins. Chrome plated 4130 Chrome Moly. 1" adjustment holes, with a total of 7" of adjustment.

#TRX 600-TW-0007 **\$27.00**



XXX 600 Top Wing Post

Top wing posts. Chrome plated 4130. Built strong so they don't bend like some we've used from other suppliers. Sold individually.

#TRX 600-TW-0004 **\$9.00**



PMP Top Wing Post

#PMP WTU-I **\$53.95 set**



PMP Nose Wing Post

Aluminum swaged tubular posts. Light and strong.
#PMP NWUPS **\$22.90**

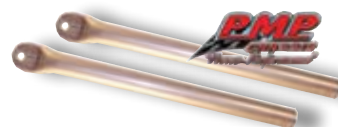

PMP Manual Wing Adjuster

Easily adjusts the rear wing on the car with one simple pin. 4130 material and chromed for good looks.

#PMP WS **\$36.95**



XXX Midget Side Knerfs

3 post and 4 post available. Measurements for 3 post: Bottom Spuds 34 1/2" center. Bottom Rear to Top Front 39". 7/8" stainless steel polished material.
3 Post **\$71.99**
4 Post **\$109.99**

Advanced Racing Adjustable Midget Shock

The Advanced Racing Adjustable Series shock is superior to any small body twin-tube shock on the market. The ARS shock uses CNC machined aluminum internal parts designed for racing with no aftermarket parts. SpeedMart stocks adjustable front shocks for midgets with an adjustable rebound. This allows the crew chief to put a riser shock on both corners but have the left front tied down more than the right. For the rear we stock an adjustable rebound for both rear corners. This allows the car to be tied down in the rear end and a crew chief can adjust the rebound on a red flag quickly as the track dries.
#ARS 107x-x/x **\$350.00**

Afco Coil Springs

- Perfect fit for open wheel, dwarf cars, and other applications that require 1 7/8" I.D. Springs
- Made to the same specifications as all AFco Coil-overs
- Fits small body shocks
- Lifetime warranty
- 8" or 10" free height

#AFC COILx **\$64.99**



Hyperco Coil Springs

The most versatile spring for sprint cars. Many rates and sizes available. We stock them in 1.875", 2.25" I.D. Available in rates from 75 to 400 Lbs depending on I.D. and overall length.
From **\$69.99**



DMI Midget Left Front Brake Mount

#DMI MRC-2800 **\$16.99**



DMI Midget Spindle

#DMI MRC-2000 **\$160.99**



XXX Midget Rear Bumpers

7/8" Polished Stainless Steel. Available in 22" or 25 1/2" versions to fit most midget chassis.
#TRX MID-BN-006x **\$70.99**



XXX Midget Front Bumper

7/8" Stainless Steel polished material. 14 1/4" Wide, 7 1/2" Deep
#TRX MID-BN-0060 **\$20.00**



DMI Midget Steering Arm

#DMI MRC-2085 **\$56.99**



DMI Midget Combo Arm

#DMI MRC-2080 **\$59.99**



DMI Midget Right Hand Steering Arm

#DMI MRC-2100 **\$36.99**



XXX Midget Front Axle

Midget Front Axle. 44" or 45" X 2" X .110 Wall 4130 Chrome Moly. Plated. Jig built for exacting quality and fit. A really great looking and finished piece. Don't be fooled by others that are un-finished, and still sell for over \$225.

#TRX MID-FA-001x Specify length **\$169.99**





XXX Midget Rear Arms

Right Rear #TRX MID-SU-0174 \$59.99
Left Rear #TRX MID-SU-0173 \$59.99



Midget Radius Rods

Polished aluminum tapped 1/2" thread in stock from 14"-22", 29"-32".

Short #MNW MRxxxx \$11.99
Long #TRX MID-SU-xxxx \$19.99

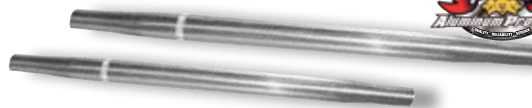

XXX Midget Watts Link

#TRX MID-SU-0002 \$42.99



XXX Midget Birdcages

Midget bird cage set (left and right birdcage). Billet Aluminum (not cast). Complete with angular contact bearings, torsion arm bolts (with washers), and radius rod bolts. Light weight and super strong.

#TRX MID-SU-0238 \$395.00 set



Midget Pitman Arm

11 1/4"-14 1/4" or 9 1/4"-12 1/4" lengths.
#TRX MID-SU-000x \$41.99

Midget Steering Gear

The midget steering gear is slightly different from the sprint car version in that it must give the driver a stiffer feel for more feedback. We've got um in stock specifically for the midget.

#KSE Gen2 MDGT \$1449.99



Midget Torsion Stop

Built for 1" Torsion Bars complete with adjuster bolt and nut.

#TRX MID-SU-0177 \$26.99



DMI Midget Torque Tube

#DMI MRC-2390 \$127.99



DMI Midget Torque Ball

#DMI MRC-2380 \$99.99



DMI Midget Torque Ball Housing

#DMI SRC-2310 \$136.99



Midget T-Bar Torsion Bar

Built exclusively for midgets and 1200 mini sprints. 28" hollow heat treated steel. Consistent feel for a great price!

#MNW TBARxxx \$94.99

.725-.850 Rates in stock

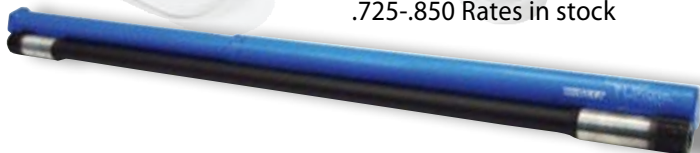

Midget 4130 Drag Link/Tie Rod

4130 Plated Tie Rod with 5/8" threads in 39-41" lengths.

#TRX MID-SU-0211 \$28.99





McKENZIE, TN. 731-352-7151

J&J Sprint Car Kits

For nearly 40 years, Jack Elam has been manufacturing race cars. The dedication to quality craftsmanship, attention to detail and willingness to build exactly what his customers ask for have helped J&J Auto Racing succeed today. Jack and the entire staff are excited to work with you and help get you and your team on the winning track.

SpeedMart is proud to announce the partnership with J&J Auto Racing to bring you the finest sprint cars on the market today. Every component is built with precision quality and used by the sports best teams. Up to date information and feedback provided from teams like Donny Shatz Racing, Mark Dobmeier, Tim Shaffer, Ed Lynch, Jr., Terry Gray, Robbie Farr, and many others including our own team in Martinez Racing gives J&J a leg up on the competition.

SpeedMart offers the entire product line of J&J components up to a complete roller and highlights two J&J chassis kits that get you started racing the best!

SpeedMart Offers a Kit that has been proven to work for most teams to get started with your J & J or replace last year's car. Chassis has 2 sets of Wing Mounts, 2 sets of Jacobs Ladder Mounts, Top Roll Cage Hoop, Left Side Safety Bar, Right Side Horizontal Bar, and 2" taller cage.

ALL BRAKE LINES
(COMPLETELY PLUMBED FOR YOU)

COMPLETE BODY AND TIN WORK
(MOUNTED AND DZUSED)

RESIDUAL PRESSURE VALVE

DZUS BUTTONS AND BODY SAVERS

RADIATOR MOUNT COMBO

BRAKE AND THROTTLE PEDALS

MSD IGNITION MOUNT

ALL BUMPERS AND KNERFS
(INCLUDING TORQUE TUBE HOOP)

RADIATOR RAMP

MASTER CYLINDER

GAUGE PANEL

TORSION STOPS

RADIATOR SCREEN

TORSION ARMS

FRONT AND REAR MOTOR PLATES



SpeedMart J&J Pro Racer Kit
\$5299.00



XXX Race Company Chassis and Body Kit

Kit Includes

- XXX Revolution Chassis
- Hood
- Left Arm Guard
- Right Arm Guard
- Dash
- Floor Pan
- Left Side Panel
- Right Side Panel
- Front Air Box
- Radiator Support

#TRX SC-CH-1001

All for only \$2350.00

2009 Bodywork add \$41.00



New for 2010

Dual Duct Hood, Nose and Armguard



XXX Race Company Standard Kit

Kit Includes

- XXX Revolution Chassis
- Hood
- Left Arm Guard
- Right Arm Guard
- Dash
- Floor Pan
- Left Side Panel
- Right Side Panel
- Front Air Box
- Radiator Support
- Front Bumper
- Left Side Knerf
- Right Side Knerf
- Rear Bumper
- XXX Right Front Torsion Arm
- XXX Left Front Torsion Arm
- 2 XXX Front Torsion Stops
- XXX Right Rear Torsion Arm
- XXX Left Rear Torsion Arm
- 2 Rear Steel Torsion Stops
- Complete Radius Rod Set
- XXX Bird Cage Set
- 13 5/8" Jacobs Ladder Plated 4130 Complete with Straps
- 50" x 2 1/4" Plated Front Axle
- Drag Link and Tie Rod
- XXX 2 Piece Front Motor Plate Set
- XXX Race Company Rear Motor Plate

#TRX SC-CH-1002

ALL FOR ONLY \$4080.00

2009 Bodywork add \$41.00

XXX Race Company Sprint Car Revolution Chassis



Built from 100% 4130 Chromeoly Tubing with the same design as the most popular chassis on the market today. Exact pickup points, motor plate location, torsion tube location, etc. . . for a fraction of the cost. All cars are 40" motor setback. Available in 87" and 88" lengths. 2" taller cages available upon request.

Standard with Left Side Safety/Sissy Bar at no extra cost.

Most other manufacturers will charge you extra for it.

We offer it standard and included in the price because we feel it offers greater driver protection, and safety is one of our highest priorities.

Halo (not welded in) is free upon request. Chassis can be ordered with halo welded in for nominal cost.

#TRX SC-CH-1000 \$1768.00

Add \$50.00 for 88" car



(Accepts Cold Air F Box)

Aero Style Snorkle Hood

This well rounded snorkle hood adapts to many "cold air boxes." Designed for Danny Lasoski. 2 pc. design with scoop nose. Perfect for 88" or 2" taller cars. Best fitting universal hood available. Great airflow.

Hood: #FTC 03H3 **\$225.95**

Nose: #FTC 03FH3 **\$98.95**

Fits 86", 87" and 88" cars.



NEW!

XXX Race Company Max Air Hood and Nose

Designed to take all of the air from the nose and the underside of the wing and force it through the giant air scoop. Contours nicely around the downtubes for an impressive fit on most any brand of car.

Hood: #TRX SC-BW-0012 **\$189.00**

Nose: #TRX SC-BW-0011 **\$71.00**

"Air Only" Snorkle Hood

Lowered snorkle and dished nose with wickerbill, plus a slope down in front. Radiator must lay back 10°. Designed for airflow. 2 pc. design.

Hood: #FTC 03H1

\$225.95

Nose: #FTC 03FH1

\$98.95



Standard Snorkle Hood

Great lines and fits well. Snorkle lays low for more air cleaner protection. Flat sides for easy vinyl application. Fits all length cars.

Hood: #FTC 00H1

\$225.95

Nose: #FTC 00FH2

\$98.95

Fits 86", 87", and 88" cars.

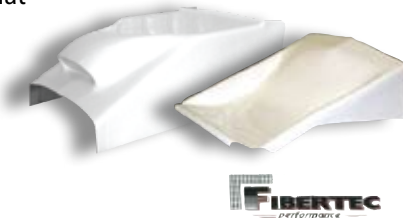

Clean Air Snorkle Hood

This hood keeps everything out of the air cleaner by pulling the air from under the car! Great for rocky or dusty race tracks.

Hood: #FTC 04H2

\$225.95

Nose: #FTC 04FH2 **\$98.95**

Fits 86" and 87" cars.



NEW!

XXX Dual Duct Hood and Nose

Brand new and very trick! All of the ducting in this hood is hidden and covered! 2 forced air ducts that come from the top of the nose and one big one from the center of the snorkle. 2 side relief ducts to let the warm air out as well. This hood will vinyl very well and looks sleek on the car! White or black available.

Hood: #TRX SC-BW-0051 **\$214.50**

Nose: #TRX SC-BW-0050 **\$83.00**

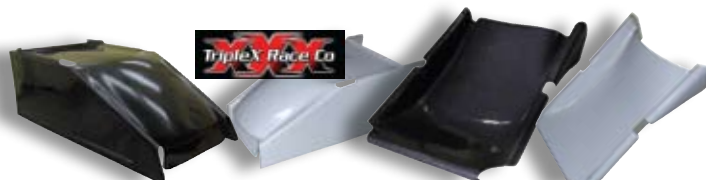

XXX Race Company Hood and Nose

Hood (clean air design). Fiberglass. Gel-Coated white. Takes only cool clean air deflected off of the air box into the motor. All dirty air is directed over and around the hood away from the motor, keeping engine (air filters) free of dirt.

#TRX SC-BW-0002 **\$189.00**

Nose (for the clean air hood). Fiberglass. Gel-Coated white. Deep dish allows air to flow under nose wing uninterrupted, then pushes all the dirty air over and around the hood, keeping engine (air filters) free of dirt.

#TRX SC-BW-0001 **\$71.00**

#TRX SC-BW-0001BK **\$77.25 (Black)**

Straight Scoop Snorkle Hood

A reinforced straight scoop really adds character to a sprint car. Used for 2 years on many Outlaw cars. 2 pc. design with sloped nose.

Hood: #FTC 02H1

\$225.95

Nose: #FTC 02FH1

\$98.95

Fits 86", 87", and 88" cars.

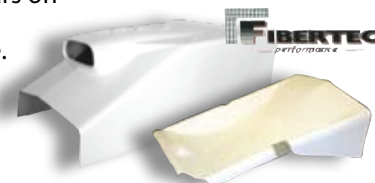

NEW!

XXX Dual Duct Right Side Armguard

Very sleek new design from XXX Race Co. Very nice smooth lines gives this armguard a finished look while giving the driver tons of elbow room. White or black available.
#TRX SC-BW-0053
\$89.99



XXX Race Company RS Armguard for Safety Bar NEW!

Right Arm Guard (for use with right side bent safety bar). Contoured to wrap right side safety bar. Fiberglass. Gel-Coated white. Encloses the right side of the cockpit, deflecting air around the driver and rear of the car. Light and strong.
#TRX SC-BW-0010
\$86.00



XXX Race Company Right Side Arm Guard

Right Arm Guard (for use with right side straight safety bar). Flat with bubble for elbow. Fiberglass. Gel-Coated white. Encloses the left side of the cockpit, deflecting air around the driver and rear of the car. Light and strong.
#TRX SC-BW-0004 **\$86.00**



Fiberglass Cowl

Fits perfectly around the motor uprights and extends the cockpit away from the driver making the cockpit very roomy. Gauges face directly into driver's eyes for easy view.
#FTC 06C-1
\$98.95



Flat Panel Cage Armguard

Sleek, reinforced design. Sloped and shaped to fit any right side flat panel cage. Curled in on top for strength. Fits Eagle, Maxim, Rocket.
#FTC 2001A **\$90.00**

Flat RS Armguard w/ Bubble

Just like Kinser's car! Avoid slapping the armguard with your right arm while driving! Fits all new long cage cars.
#FTC 05A-1
\$95.00



Rocket RS Flat Armguard with Bubble

Tons of arm room in a flat right side cage car with our formed fit RS armguard. Top flat lip gives it tons of strength. Looks Very Sleek!
#FTC 06A-1 **\$95.00**



Rocket Chassis Right Side Armguard

Totally redesigned in 2007. The smoothest contour of any armguard on the market today. Increases cockpit room for drivers right elbow.
#FTC 07A-1 **\$95.00**

Safety Cage Armguard

The recent standard for safety cage design. Great area for sponsors and signage. Keeps cockpit really clean! Very versatile shape for many cars.
#FTC 00A1 **\$95.00**

Fits early model chassis and standard cage cars



Rocket LH Formed Panel

Form fitted to mold to a 2006 or later Rocket Chassis perfectly. Covers everything on the left side, tubes and all. Great, finished look. Super strong.
#FTC 06P-1 **\$65.00**



LRB Motorplate

Available with Chevy standard and narrow patterns. In stock for J & J and Maxim/Eagle. Made from 6061 aluminum. Allows 3 hole adjustment. Machined from both sides for maximum strength. Ultra-Lightweight but strong. Machined after anodizing for an awesome finish! Angled up at bottom raised rail cars. #LRB RMP (specify chassis) **\$239.99**

NEW!



King Rear Motor Plate

King's Aluminum Rear Motorplate is engineered for maximum strength. Made from 7075 Aluminum and all mounting holes are available for lightweight and standard blocks. Works on Standard or raised rail cars. Fits all major chassis manufacturers. #KRP 1510 **\$184.95**

NEW!



Safety Cage LS Armguard

One of the best places on a sprint car to finish your graphics and complete your design. Also keeps a lot of the mud away from the driver. Designed for standard cages. #FTC 00P-1 **\$65.00**
Fits early model chassis and standard cage cars



XXX Race Company Left Side Arm Guard

Left Arm Guard (for use with left side safety bar). Fiberglass. Gel-Coated white. Encloses the left side of the cockpit, deflecting air around the driver and rear of the car.

Light and strong. #TRX SC-BW-0003 **\$51.00**

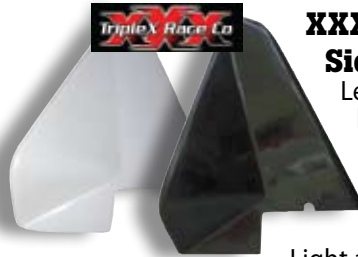

XXX Race Company Aluminum Rear Motor Plate

Rear motor plate. Aluminum. For Raised Rail cars. Triple X Logo CNC'd into plate. Lighted in inside (side facing drivers compartment) so dirt does not get trapped in lighting pockets. All holes are drilled and tapped. Has multiple mounting holes for pumps (to fit standard, and raised cam engines). Fits XXX, Maxim, and Eagle. #TRX SC-EG-0006 **\$144.00**



XXX Tin Work Kit

#TRX TWK **\$239.95**

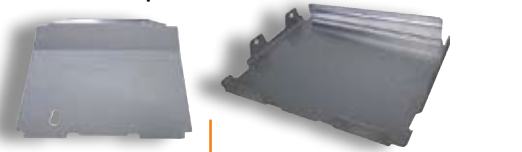

Sprint Car Radiator Support
TRX-SC-CH-0004
\$40.90

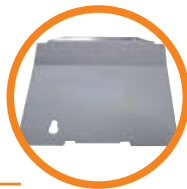

Sprint Car Dash
TRX-SC-BW-0008
\$43.00



Sprint Car Left Side Kick Panel
TRX-SC-BW-0005
\$31.00



Sprint Car Radiator Ramp
TRX-SC-CH-0003
\$41.00

Sprint Car Floor Pan 20-1/4"
TRX-SC-BW-0007
\$48.00
New 17-1/4" available

Sprint Car Right Side Kick Panel
TRX-SC-BW-0006
\$49.00
2 Piece

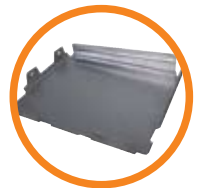



Radiator Tray

Dzuses right into your chassis will fit most newer model chassis.
#ROC PNLRTRAY \$32.95

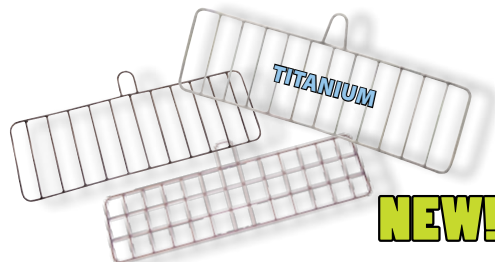

NEW!

Sprint Car Rock Screen

A driver once said, "Cover your eyes. What do you see?" Use One!

4130 Powdercoated Black #HRP 8069 \$63.99
Crossbar Rock Screen #WIR ROCSC \$43.99
Titanium #T22 1029T \$159.99



Carbon Fiber Dash

These look so cool in a cockpit! Gauges reflect off of the black, making them very easy to see. Nothing makes a car look lighter than one of these! Thick area on dash panel so gauges don't move around.
#FTC CF-D \$195.00

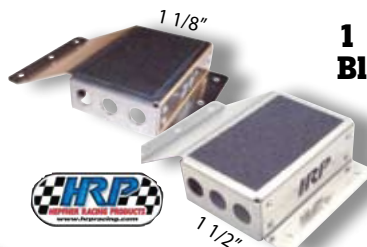

1 1/8" & 1 1/2" Heel Blocks

Non skid on top. The best heel blocks on the market. Pre-drilled Rivet Holes even!

1 1/8": #HRP 8062 \$22.95
1 1/2": #HRP 8063 \$22.95

Aluminum Sun Visor

A must have at many tracks. Also a great place to accent the driver's name!
#HRP 8319 \$29.99



Carbon Fiber Visor

To block sun and adds a mean look to your car.
#KEN VISOR \$134.95
#FTC VISOR \$79.99



NEW!

J&J Aluminum Sprint Car Visor

Built to fit any sprint car with single or double wing mounts. 7 1/2" long in center for great sun coverage.
#JNJ 101020 \$65.99

Kenny's Components Carbon Fiber Dash

A perfect way to lighten up your car, and give it that mean look. Fits in a Maxim, Eagle, and Rocket Chassis perfectly.
#KEN KC28MSD \$229.99

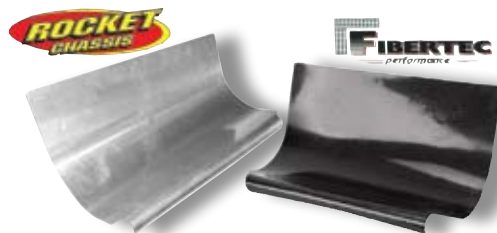

Radiator Ramp

Radiator ramps do two things: Create down force so your car turns easier at the end of the straightaway and force more air through the radiator cooling your engine more efficiently.
#FTC ADAM \$85.95
#ROC PN RAMP \$59.99



Complete Bolt Kit

Fits most 2005 or later chassis regardless of brand. All grade 8 bolts measured to fit right into car, no issues! All separated into bags and labeled with a list of what is in each kit. A great idea to have one in your tool box so your crew can grab the right bolt in a hurry!

#SMI A-BKT STL \$134.95





XXX Aluminum Front Bumper
CNC bent for exact fit.
#TRX SC-BN-0009 **\$12.50**

8" Front Bumper

Polished stainless steel for strength. Super strong to keep your torsion tubes from getting bashed in.
#ROC FB **\$19.95**



XXX Stainless Front Bumper
Stainless steel front bumper. Polished to perfection. CNC bent for exact fit.
#TRX SC-BN-0010 **\$11.00**

J & J Front Bumper

Unique for a reason. Slight bend in front of bumper deflects objects away from car and prevents bumper from getting caved in wrecking your front torsion tubes. Sold in aluminum or stainless.
#MNW FB-100-JJ **\$15.99**

NEW!

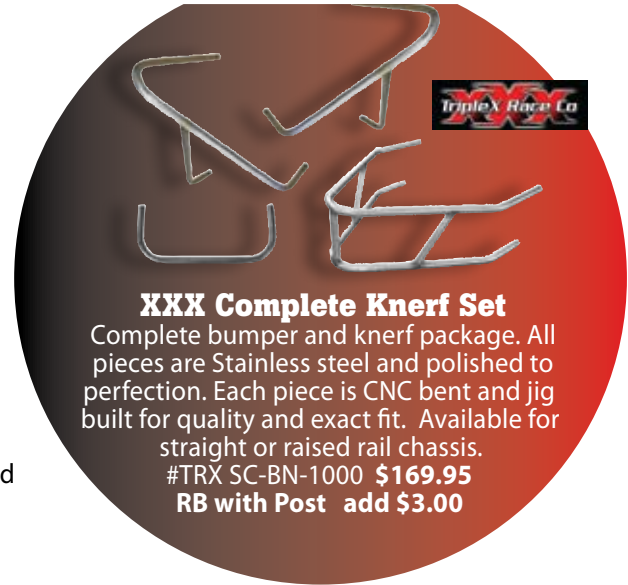

XXX Complete Knerf Set

Complete bumper and knerf package. All pieces are Stainless steel and polished to perfection. Each piece is CNC bent and jig built for quality and exact fit. Available for straight or raised rail chassis.
#TRX SC-BN-1000 **\$169.95**
RB with Post add **\$3.00**

Stainless Rear Bumper With Post

Tons of bracing keeps your tail tank from getting destroyed. Made from stainless steel for lasting appearance.
#ROC RB04 **\$85.00**

Fits J&J, Rocket, Eagle, Maxim 2004 and later chassis.



J & J Rear Bumper

One of a kind and simply the strongest around! The entire bar is radiused to save your tail tank in an impact, and it works! Chromed.
#JNJ 101002AC **\$139.99** **NEW!**



XXX Rear Bumper with Post

Stainless steel rear bumper with post, no basket. Post helps avoid push truck (and other cars) from jumping the bumper and getting into the tank. Polished to perfection. CNC bent and jig built for quality and exact fit. Fits most chassis.
#TRX SC-BN-0012 **\$72.00**



XXX Rear Bumper with Basket

Stainless steel rear bumper with basket and post. This is the strongest configuration available; the basket protects the tail tank from damage. Polished to perfection. CNC bent and jig built for quality and exact fit. Fits most chassis.
#TRX SC-BN-0007 **\$82.00**



Right Side Knerf

XXX Right Side Knerf
Stainless steel right nerf bar. Shorty style. Polished to perfection. CNC bent and jig built for quality and exact fit. Fits most chassis.
#TRX SC-BN-0001 **\$48.00**



Left Side Knerf

XXX Left Side Knerf (raised rail or straight rail chassis)
Stainless steel left nerf bar. Shorty style. For raised rail chassis. Polished to perfection. CNC bent and jig built for quality and exact fit.
#TRX SC-BN-0011 **\$48.00**
#TRX SC-BN-0003 **\$48.00**



Stainless Shorty Side Knerfs

Fits Rocket, Eagle, Maxim, & Stealth cars. Available in 1" raised left side or STD.
Right Side: #ROC KN RSS
Left Side: #ROC KN LSS
Raised Rail 1" Up
#ROC KN LSSRR
\$65.00 each



Aluminum Dzus Button Kits

We've got them in various lengths at a great bulk price!

Short #DZU SAEXS \$16.99

Standard #DZU SA \$16.99

Long #DZU SAL \$16.99

Available in 10 packs



OUR DZUS & SPRINGS COME IN HANDY PACKS OF 10!

Dzus Transfer Punch

A tool that makes drilling body panels EASY. Simply set this little guy in the dzus tab, put the body over the car and tap it to make a perfectly centered drilling hole for your sprint body!
#DZU 8420 **\$2.99**

NEW!



Large Head Dzus

Finally! Why didn't we think of this sooner? 7/16" shank standard sprint car dzus with an oversized head for cracked out fiberglass or miss-drilled holes on your sprint car. Sold in packs of 10. Bigger than a quarter!

#DZU SABIG **\$19.99**

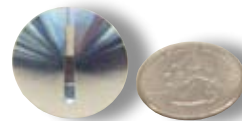

NEW!

Lightweight Steel Dzuses

Lighter than aluminum dzuses. Comes complete with their own washer. Available in 10 packs.

#DZU SL **\$9.99**



Mini Sprint Dzus Buttons

Used for 1/4 midgets, & most mini & micro sprints. Hard to find! Available in 10 packs.

#DZU MSA **\$12.99**



Dzus Springs

Available in 1" or 1-3/8".

Mini Sprint 1" - 10 Pack:

#DZU MSSPR **\$8.99**

Sprint Car 1-3/8" - 10 Pack:

#DZU SSPR **\$7.99**

Uses 1" for minis, micros and 1/4 midgets



Body Savers

Save your fiberglass! Easy to install. Many styles & shapes available. Available in 5 packs.

Light: #DZU A-BSL **\$3.99**

Round: #DZU A-BSR **\$4.99**

Oval: #DZU A-OBS **\$4.99**



RUE Shock Clips

Won't come off on rough tracks like others! Available in 3/8", 1/2", and 5/8".

Sold in 5 packs.

3/8": #AST A-1001 **\$4.99**

1/2": #AST A-1002 **\$4.99**

5/8": #AST A-1003 **\$4.99**



Aluminum Heim Spacers

#BPW 0804A **\$1.25**



1/4" Quick Pins

Great for wings for easy removal.

#CHA 240-801 **\$1.95 ea.**



AN Washer Kit - 145 pc.

#FAS FS4 **\$18.99**

Aluminum Jet Nut Kit - 40 pc.

#FAS FS12 **\$31.99**



Pop Rivet Kit

#FAS FS3 **\$18.99**

Steel 1/2 Nut Kit - 105 pc.

#FAS FS1F **\$18.99**

Aluminum Shock Spacers

Only .200 Thick, perfect for shock heim movement throughout the car. Sold in 10 packs.

#KMI SSK **\$11.50**



R Clips for Shocks or Wing T's (or Whatever!)

You might even need some in the trailer!

#CHA A-RCLIP-5pk

\$5.25



LIGHTWEIGHT



Titanium Watts Link Pin Kit
Easy to change in a wreck and really light! All pieces provided to make installation a snap.
3/8" Car 1/2" Watts Link
#AST 951 \$47.99

Titanium Torsion Stop Bolt w/Jam Nut
1/2 the weight of steel torsion stop bolts, & they last twice as long. Won't stick or ruin the threads in aluminum torsion stops either.
#AST 5719 \$15.99



Titanium Tubular King Pin
Available in the long version also.
#DMI SRC-2059 \$81.99



DMI Titanium Spindle
Available with step or straight snout.
Straight Ti Snout
#DMI SRC-2020 \$229.99



Titanium Right Front Steering Arm Bolts
Mounts the right front steering arm through the spindle on any brand spindle. Sold in pairs.
#AST 5817KIT \$35.99 set

6AL-4V Titanium Torsion Stop
The best value in titanium stops! 1 3/4" Split
#BEN TTS \$159.99



Titanium Inboard Brake Rotor Bolt Set
A complete kit for the inboard rotor. Coarse thread to thread directly into rotor clamp, and sized to perfect length.
#AST 4510IB \$45.99



Featherlite Brake Setup
The ultimate sprint car brake. Utilizes a 10.4" ceramic coated vented .810" titanium or steel rotor with our lightweight 200 series caliper. The .810" vaned titanium rotor weighs only 2 lbs. 11 oz, and the steel weighs only 4 lbs. 2 oz. Steel is investment cast 8740 chromoly. Redesigned caliper mount for ultimate strength. There is no better, lighter, brake system!
Featherlite Steel Setup #RED FEA-4130 \$1195.00

Titanium Rotor Setup #RED 410-8100
NEW LOW PRICE \$1369.99



Titanium Inboard Brake Caliper Bolts
Sold in sets of 2. Bolts caliper directly to rear end. Very strong!
#AST 4715KIT \$22.99 set



Titanium Front Rotor Bolts
Beveled perfectly to mount any sprint car front rotor to all front hubs.
#AST 3507KIT \$33.99





SpeedMart's Custom Ultralight Rear End

We built this one for the racer who wants to cut as much weight as he can without sacrificing longevity. EVERY part inside of this rear is lightened, titanium, or aluminum. The axle, however is a lightweight, not an ultralight. Most teams who run 360 and 410's don't want to have to change out their ultralight axle every 10 races like is recommended. The lightweight axle still saves 4 pounds over the standard axle. Ultralight axles are always available, and we carry one in stock, for those who run them.

- 4:12 #WIN SM412LW \$2725.99
- 4:86 #WIN SM486LW \$2680.99



NEW!

Lightweight Black Anodized Driveline Kit

Our own lightweight kit with simply the best combination of components for your sprint car. The King Racing Products Torque Ball and Housing fits perfect and has awesome movement with almost no play. We tested them all and this one was the best! The LRB Torque Tube is a perfect fit inside the King Torque Ball. Kit comes complete with a DMI Hollow Steel Driveshaft. Entire kit weighs 14.25 pounds.

#SMI K-DLLW \$599.99



DMI Hollow Titanium Driveline

Larger O.D. than other brands to prevent vibration but oh so light! 6AL4V titanium.

#DMI SRC-2480 \$785.99

Ti22 Titanium Wing T

Ti22's Wing Tree is designed to be a lightweight addition. With an extra inch added to the length, the tree is able to achieve the wing angled needed for today's wings. The tree comes with bottom inserts for easy wing adjustment. Weight: 1 lb. 11 oz

#T22 10787T \$189.99

NEW!

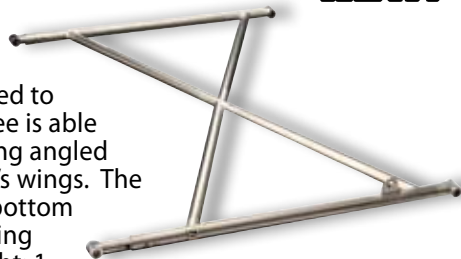

Alum U-Joint

7075-T6 aluminum U-joints will even hold up to high torque 410's!

#WIN 3700 \$169.99

Ti22 3 Hole Adjustable Titanium Watts Link

Ti22's Three Hole Jacob's Ladder can be easily adjusted to help tune the chassis to variable track conditions. The titanium option significantly reduces part weight by more than 1/2 lb over the standard chromoly ladder. Sizes: 13 5/8", 13 1/4" and 14".

#T22 1007T \$149.99



NEW!

DMI Lightweight Torque Tube

The truest torque tube we've found. Lightened everywhere where strength isn't compromised. Long collar provides stability for the increased traction of today's cars.

#DMI SRC-2393 \$137.99



Titanium Torque Tube Stud Kit

A complete kit of ti studs, AN washers and full nuts. Super light, and way easier than using bolts.

#AST 935-TT \$44.99

LIGHTWEIGHT



Titanium Front Hub Bolts

Available for both Weld and DMI hubs. Recessed ends to allow nuts to screw right on without jamming or cross-threading. Super light yet very strong. #AST 5507KIT \$77.99



Titanium Brake Pedal

This thing is so light! Works in any of the new cars- raised rail or not. Made from 1" tubing for zero deflection. #BCK TI BRK \$109.95



Titanium Front Axle Shock Studs

Titanium screw in studs for front axle to quickly put shocks on the car. One nut or quick pin styles available. Get a set for your spare front axle also!



One nut #AST 9319 \$17.99
Quick Pin #AST 9520 \$18.99



Titanium Front Hub Nuts

New for 2009! Titanium nuts for the front wheels! 6AL-4V material so these are super strong yet very light! #MET NUTFH \$11.99 ea.

Titanium Wing Valve Bolts

Bolts the wing valve to the chassis. #AST 4405KIT \$9.99 set



Titanium Throttle Pedal

All the cool things that the 4130 pedal has, and weighs next to nothing! 9 1/2" overall length. Perfect for most chassis throttle bolt configurations. Won't rub on ankle bone! #BEN TPTI \$132.99

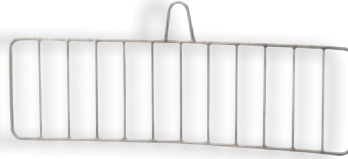

Titanium Sprint Car Rock Screen

A driver once said, "Cover your eyes. What do you see?" Use One! Titanium #T22 1029T \$159.99



Titanium Knerf Bolt Kit

Contains 14 hex head titanium bolts and 14 jet nuts to fasten all knerfs, bumpers, and torque tube hoops to any late model sprint car. Sized perfectly. #MET KBK \$64.95



COMPLETE Titanium Bolt Kit

We've got um in stock for Rocket Chassis, and we can get um for Eagle and Maxim! Saves 3 pounds! Bolts are machined with perfection, and all fit exactly right. This one is COMPLETE! #AST A-1114 \$1199.99

Everything you need to connect your Gen 2 steering gear to your top wing.

Lightweight Kit for Gen 2 Steering Gears

- Wing cylinder (1)
- MPD lightweight wing valve (1)
- #3 ORB to #4 JIC St. (2)
- Kevlar 18" Wing Line (2)
- Kevlar 22" Wing Line (1)
- Kevlar 34" Wing Line (1)
- QA1 Wing Heim (1)
- MPD Cylinder Wiper (1)
- XRP -4 x 1/8" NPT 90 (2)
- XRP -4 x 1/8" NPT 45 (4)
- #SMI K-WSG2 \$359.95



Titanium Top Plate Bolt Kit

Every bolt you need to bolt the top plate to your tail tank. A great place to save weight because the bolts are placed high on the car #AST 5408KIT \$61.99 set





Titanium Front Axle to Radius Rod Bolt

The perfect length to fit through the axle bracket for the radius rod. Custom cut shank to keep the threads intact as suspension works. Sold in kits of 3.

#AST 5814KIT \$43.99



Titanium Radius Rod Stud Kit

Same style as the shock kit. Only one wrench needed to take a rod off of your car. Great in a thrash. 6 Rod Bolts and 3 to hold the front rods onto the front axle.

#AST 1257 \$169.99

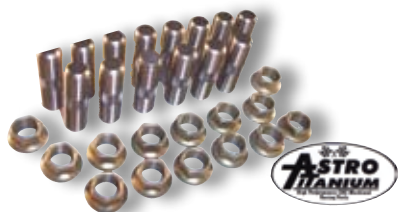

Titanium Header Stud Kit

The lightest way to attach your headers to your motor. Comes complete with all studs and nuts required.

#AST 1120 \$98.99

Titanium Tie Rod/ Drag Link Kit

All 4 studs needed to connect your tie rod and drag link to front end and pitman arm. A great addition to the shock and radius rod kits. Super strong!

#AST 1259 \$76.99



Titanium Shock One Nut Studs

One nut on the front side of the stud that you actually take on and off, but the other side is fixed so only one ratchet is needed. You will love these. In stock for Rocket thread in front axles. We also sell other combinations for your chassis.

#AST 1253 \$172.99



Titanium Quick Pin Shock Kit

A complete kit to fit most late model chassis. Comes with nuts, spacers, clips, and studs. Mounts a complete set of shocks to car.

#AST 1256 \$191.99



Ti Beadlock Bolt Kit

Saves 1 lb per wheel which turns into over 85 lbs @ 100 MPH! With titanium prices rising, get these now. They last forever.

#AST 4510KIT \$79.99

#MET BLBKT \$66.99 **NEW!**

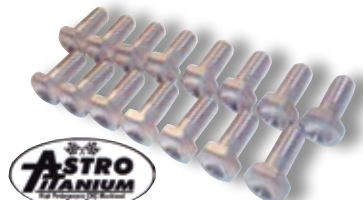

Ti Wheel Center Bolt Kit

Made for Weld Wheels. Aircraft titanium, not the cheap stuff that snaps. 15 bolts and hardened washers. Will adapt to Weld or DMI replacement wheel centers.

#AST 5507KIT \$77.99



Left Front Steering Arm Bolts

Tapered head countersunk bolts sized perfectly for the left front steering arm of a sprint car. Tighten them down with an allen and go!

#AST 3519KIT \$28.99 set



Ti Seat Bolt

Check these out! Titanium 3/8 shank button head bolts with a large flat surface for strength. No more bruises on your back.

#AST 935-158 \$17.95

KINSLER 360 ASCS INJECTOR

The absolute best injection for your ASCS 360 motor. 20+ ft. lbs. of torque gain and 20+ horsepower over any other brand of injection from 4000-8000 RPM. Smooth as silk throttle response for increased driveability.

- 2 1/2" throttle size
- Port profile: ASCS with standard bolt location and port window.
- Jack-shaft throttle linkage
- Precision ground hard-nickel plated dual milled style on piece throttle shafts and aluminum throttle plates.
- Set of (8) Kinsler ram tubes, 180 Deg. Tapered bell 2 1/2" I.D.
- Set of (8) Kinsler 1/2-20 thread internally vented nozzles with 5 1/2" long flowed and matched within 1% spread in total distribution.

2.5" Dragon Claw: #KIN DCLAW \$3945.40

2.375" Dragon Claw: #KIN DCLAW \$4100.00



NEW!

FSR Engine Mount Radiator Kit

New from FSR this year. A complete radiator system that bolts directly to the motor. Cross Flow design for increased cooling and supplied with all necessary components to hook directly up to a KSE water pump system. -10 Oring Boss Fittings lined up on the right side. Complete with all brackets and hoses.

#FSR 1105 **\$459.99**



Kinsler "Jack-Shaft" Throttle Linkage

Stainless steel cross bar that replaces the standard linkage. Mounts in bearing style pedestals with 'adjustable' hex link assemblies going up to both sides of the manifold. Throttle arm located on 'jack-shaft' with throttle stop and boss stop.

#KIN 20260 **\$297.99**

King Wash Plugs with Spark Plug and Nozzle Keepers

All aluminum anodized o-ringed plugs for the injector of your car to keep water out when washing. When car is put away leave them installed for a place to put each spark plug and nozzle when doing motor maintenance. Built for all sizes of injectors, *specify size when ordering.*

#KRP 1935-1943 **\$128.99**

NEW!



Dan Olson Valve Covers

Perfect clearances for all racing series rocker arms and stud girdles. Made by the same company that brings you the best oil pans on the market. Solid aluminum with fully machined rails. Very nice fit!

#DOP VC100 **\$399.99**



ALLSTAR PERFORMANCE



Valve Cover Breather

Available shielded or non-shielded. Sold in 1-1/2 and 1-3/8" diameter to fit most any valve cover.

#ALL 36202 **\$15.95**

Peterson Restrictors

IN STOCK! Almost every 360 race series in the country requires a 2-3/16" stack I. D. All of the newer injectors are 2-1/2 or 2-7/16! Peterson makes the smoothest flowing restrictor, and they're super easy to install. Sold in sets of 8.

2-1/2" #PET 12-2100 (8) \$207.99

2-7/16" #PET 12-2101 (8) \$207.99



Injector Hex Link

2 1/4", 4 3/4", 5 1/8"

Your premade cross links make stripped out links a snap!

#HIL F60-LENGTH **\$34.99**



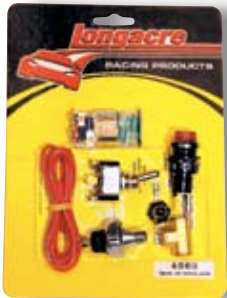

Now NEW Sealed Switches!

Low Oil Pressure Warning Light & Kill Switch

Includes holder for 9V battery, special bulb, heavy duty mag switch, weatherproof switch cover and wire.
#LON 45624 **\$39.95**

Now NEW Sealed Switches!



Magneto Switch

Extra heavy duty switch designed to hold up to the strong current of today's powerful magnetos. Will work with all magnetos except MSD.
#LON 45423 **\$16.95**



Complete Throttle Linkage Kit

This kit is sooo easy to use! We stock various length rods for different motors and cars. Complete with 4 heims, 4 nuts, 2 rods, and a LW bell crank.

Rod Lengths:

Std Rocket & Eagle - 16" & 8";
w/ Titanium Throttle Pedal - 18" & 8"
Complete Kit #SMI K-CTL \$69.99
(Specify Length of Rods)

LW Bell Crank

Tons of adjustments, nicely fit bearing for positive throttle feel.
#KRP 2060 **\$19.99**



NEW!



XXX Race Company Sprint Car Throttle Pedal

Sprint Car Gas Pedal (with toe bar). Lightweight 4130 Chromoly. Black powder coat. Fits all cars that have spud attached to frame rail.
#TRX SC-CH-0006 **\$32.95**



Swedged Throttle Rod

Makes hooking up your throttle a snap combine these with some ultra light aluminum heims. Tons of different lengths to choose from.
#MNW THRXXX **\$12.95**
(Specify Length)



Titanium Throttle Pedal

The lightest throttle pedal made! 9 1/2" throw fits most cars.
#BEN TIPI **\$132.99**



Aluminum Throttle Pedal

Lightweight, rugged aluminum pedal assembly mounts to the floor pan, providing smooth throttle control. Complete with fasteners.
#ALL 54106 **\$49.99**



4130 Throttle Pedal

This Ultra light throttle pedal is a favorite with drivers. Long pedal action to help provide smooth throttle control. An upper toe hold to allow you to pull up on the pedal. A 10/32 bolt welded right to it so all you have to do is hook your heim up and go!
#ROC TTP **\$51.99**



King Billet Throttle Arms

King's Racing's Billet Aluminum Throttle Arms are the nicest on the market. Ultra Light and Ultra Strong available in 5/16" and 3/8".

5/16": #KRP 2065 **\$15.99**
3/8": #KRP 2070 **\$15.99**



NEW!

Aluminum Throttle Heim

These ultra light aluminum heims are lighter, stronger, tighter than cheap steel heims, a good replacement item for all of your injector heims.
#FKB ALJM3 **\$8.99**
#FKB ALJML3 **\$8.99**



SpeedMart Pro Mag Kit



This kit has everything you need! Mag, Points Box, Wires and Switch.
#MSD 7908K **\$2099.99**



Sprint Pro Mag Premade Wires

The best spark plug wires on the market. Required with MSD Pro Mag because of its high voltage. Fits perfectly for sprint cars.
#MSD 31549 **\$109.95**

Pro Mag 12 Points Box

Designed to handle the voltage of the Pro Mag 12LT. Comes with rev limited chips, switch and wiring harnesses.
#MSD 8106 **\$565.00**



Pro Mag Wiring Kit

These Pro Mag Wiring Repair Kits are designed to be used for emergency wiring fixes while at the races. Both Kits are supplied with the strain relief that mounts to the generator, wires, two 4-Pin connectors and screws.
#MSD 8124 **\$69.99**

Pro Mag 12Lt

Designed exclusively for sprint cars. Compact ultralight housing, rare earth magnets and rynite insertion molded cap. Used by all high performance engine builders. Requires MSD points, box and wires.
#MSD 7908 **\$1459.99**



MSD Ignition Box Mount

The only ignition box mount made by MSD themselves. Mounts with two single dzus holes and fits the MSD box perfectly.
#MSD 8102 **\$37.99**



J & J MSD, Switch and Tach Mount Complete

The most complete system for your dash! Ultralight powder coated aluminum bracket with dzus holes and all springs installed. 3 Holes and the entire system is on your car!
#JNJ 101024NX9 **\$28.99**



NEW!



Replacement Switch & Connectors

Multi-Car or replacement switch kit.
#MSD 8111 **\$61.99**



MSD Cap & Rotor

A must have in your spare parts!
#MSD 7919 **\$69.99**

Coil Wire

MSD recommends replacing your coil wire every 8 races. With the high power these mags put out, the coil wire loses efficiency fast.
#MSD 84039 **\$15.99**



Vibration Mounts

Racing produces a tremendous amount of vibration from tire shake and engine power not to mention the occasional bump and grind in the corners. These Vibration Mounts are just the thing to help isolate severe racing vibrations from the Pro Mag Electrical Box or other accessories. Four mounts and hardware are included in each kit.
#MSD 8823 **\$14.99**



Pro Mag Gear

MSD Bronze Pro Mag Gears are machined from quality AMPCO 45 aluminum bronze containing 5% nickel. This special combination creates high strength gear teeth that are less prone to wear.
#MSD 8471 **\$50.99**



HRP Gauge Mount



This gauge mount holds both gauges plus your ignition switch. Dzus's to your dash. Set your spare motor up with gauges and ignition ready!
#HRP 8361 \$10.99

H2O Temp Gauge Bulb

Perfect for the side of your cylinder head to insert your temp Gauge. Hard anodized for protection against corrosion.



#KRP 2130 \$10.99

Mini Water Temp Gauge

2" mini Gauge Reads from 140 to 280 just like its big brother. Great for mini sprints.

#ATM 4331 \$80.99



Tel Tac II

A Great TAC for the racer who only wants to know their highest RPM.

#TEL II \$295.99



90 Degree Line Adapter

Trick aluminum 90° fitting screws on back of your oil pressure gauge ready for your -4 line

#ATM 3278 \$8.99



Mini Oil Pressure Gauge

2" Mini gauge Reads 0 to 100 PSI. Perfect for mini sprints.

#ATM 4321 \$54.99



RaceAir Pro

Complete fuel computer. After a dyno session you can completely automate your fuel system. Program for any track you go to.

#CSI 1000-RAP \$469.95



J & J Dual Quick Release Gauge Mount

Outlaw teams are the masters of engine changes. When they change an engine, the MSD Box, Radiator and gauges come with it. This gauge mount is the simplest on the market. Gauges sit out in front of driver for a unique appearance.

#JNJ 101024N9 \$28.99



Ultra-Nite Water Temp Gauge

Easy to read 140-280° gauge for EZ visibility with no battery.

#ATM 4535 \$99.99 4' Capillary

#ATM 4531 \$99.99 6' Capillary



Tel Tac Oval Track Pro

The Tacometer used by all of the Outlaws. Reads 4 high and 4 low RPMs in hundreds. You can learn a ton about your setup from the low RPM, and your motor from the highs. Flashes all 4 readings for 15 minutes. Also available—wiring harness needed for multi car teams.

#TEL OTP \$424.95

Tel Tac Wiring Kit Complete

Complete kit ready for a switch.

#TEL HARNESS \$29.99



Ultra-Nite Oil PSI Gauge

Easy to read 0-100 PSI gauge for EZ visibility with no battery.

#ATM 4521 \$69.99



Isolator Wire

Replacement isolator wire for TEL TAC

#TEL ISO \$10.99



HRP Tel Tac Mount This mount makes removing and installing your TACH a breeze with just 2 Dzus buttons

#HRP 8362 \$9.99



SpeedMart Prefit Sprint Car Plug Wires

No building, no hassle. Applicable to all mags. The most common loss of horsepower is old spark plugs & wires. Protective coating on wires for all types of racing. Available in black, blue, grey, red, or yellow. Includes coil wire.



#SCO SMXXX \$119.99



Deluxe Spark Plug Reader

The secret to horsepower is in the spark plug. Without a bright light or magnifying glass you can't properly tune your engine. Used by all the top Cup teams.

#LON 50886 \$39.95

TECH TIPS

Spark Plugs:

The heat range of the spark plug determines how much heat the spark plug is capable of removing from the combustion chamber. The heat range of the spark plug does not increase or decrease horsepower. It changes the temperature of the tip of the spark plug. If the heat range is too cold, the deposits will not burn off the tip and the spark plug will foul. If the spark plug heat range is too hot, pre-ignition can occur. A switch in heat range of the spark plug will change the temperature of the spark plug tip by 70-120 degrees. If you are unsure of the correct heat range to use, always start with a colder spark plug. If the plug is too cold, the plug will eventually foul and a misfire will occur. This will not hurt the engine. Unfortunately, though, if a spark plug that is too hot is inadvertently chosen, pre-ignition and detonation can severely damage your engine. Don't go to a hotter heat range unless you've consulted your engine experts.



MSD Ignition Mount

Dzuses to dash for easy removal during washing.

#HRP 8360 \$15.95



Spark Plug Deflectors

Don't let a rock knock you out of a race. Use these to protect your spark plugs and nozzle lines.

Straight Tube Headers #HRP 8336LH \$11.99
#HRP 8336RH \$11.99

Swept Forward Headers



#HRP 8329LH \$10.99
#HRP 8329RH \$10.99



Spark Plug Indexing Washers

Frustrated with not being able to get your plugs indexed just right? Use these flat washers.

#MOR 71910 \$21.95

Autolite Spark Plugs

Box of 4 \$10.95

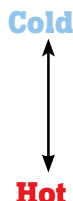

HEAT RANGE CHART

SPARK PLUG NUMBER			
3932	2592		
3933	2593		
		3910	50
		3911	51
			52
5/8 Hex	13/16 Hex	5/8 Hex	13/16 Hex



Mallory Condenser

Condensers breakdown and should be replaced yearly.
 #MAL 28005A \$37.95
 #MAL 28005 \$41.99



Replacement Cap for Mallory Sprintmag II & III

Carbon Tracking and small cracks can be hard to see. Replace your cap and rotor yearly to maintain a crisp engine
 #MAL 205M \$64.99
 #MAL 208M \$44.95

Replacement Points

Points should be replaced yearly. Simple to do!
 #MAL 25758M \$26.99



Mallory Sprint Coil

Used with Sprint Mag 2 or 3. Mounts to dash panel with two 1/4" bolts and connects with a coil wire and wired direct to magneto. Easy to change and very durable. Specially formulated oil cooling to insulate windings within.
 #MAL 28900A \$228.99



Mallory Static Timer

The best way to set your mag timing before firing the car. Box will buzz until the timing of the magneto is perfect. Simply loosen the mag-to-base clamp and spin the generator until the box stops buzzing. A must have for setting timing.
 #MAL 28355 \$174.99



Flaming River Timing Light

The easiest timing light in the world for sprint car mechanics. These things are tough and will take the abuse of a dirt race team!
 #FRI 1001LIGHT \$57.95



Sprintmag II

The most widely used magneto in sprint car racing. Reasonably priced and very reliable. Comes complete with coil and wiring accessories.
 #MAL 4359524 \$1020.99



Replacement Rotor for Mallory Magneto

Replace with Cap to keep engine running crisp.
 #MAL 28995 \$44.99

NEW!



MSD RPM Module Kit

A 5 pack of MSD RPM chips that plug into the Pro Mag Ignition Box. These chips do not allow the engine to rev past the RPM you select. Easy to lose so make sure you always have a spare. Available in 8,000-8,800 or 9,000 to 9800 RPM.
 8,000 to 8,800 RPM #MSD 8748 \$30.99
 9,000 to 9,800 RPM #MSD 8749 \$30.99



Sprintmag III

Need more spark? More amps and longer spark duration than Sprint Mag II a must for 410's.
 #MAL 5358514 \$1179.99



Band Clamp

This extra strong, locking band clamp is required when using a Band Clamp magneto mount (12 or 44 versions). The stainless steel clamp tightly locks and holds the generator to its drive housing.
 #MSD 8146 \$81.99

FSR Block Heater

Pre Heat water in your engine to race temperature and "Keep it Hot" An inexpensive way to keep your engine race ready!

#FSR 120832 **\$349.99**



Also Available for Raised Cam Motors!

Gaerte Front Cover

Another awesome part from Gaerte Engines, fits most major brand oil pumps. Comes in standard and raised cam versions.

#GRE VTS8000 **\$225.99**

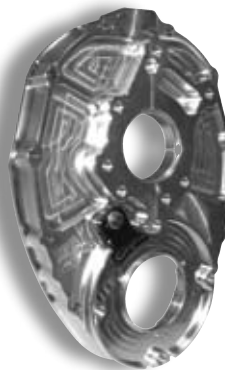
**KSE Front Timing Cover**

Timing cover is compatible with all gear and chain cam drive systems and has bolt patterns to accept all popular dry sump pumps.

Aluminum: #KSE KSD 1002 **\$159.99**

Mag: #KSE KSD1002M **\$233.99**

**KSE Water Pump**

Cool your engine with water.....Not fuel! KSE's water pumps are CAD-developed for today's high-performance engines:

- Timing window with four possible location
- Eight variable inlet port locations
- Indestructible welded tang drive
- Mechanical ceramic seal
- 1 1/2" inlet fitting
- Two 3/4" NPT outlets
- Cast 6-vane impeller
- Designed for engines up to 700 HP

#KSE KSD1001 **\$383.99**

**Water Pump Impeller**

A lot of the older water pumps don't have this new and improved impeller. 30% more flow for increased cooling.

#KSE KSD1089 **\$92.99**

**Easy View Timing Window Cover**

Tired of changing lexan windows on your KSE Water Pump so that you can see the timing mark. Here is your solution. Simply unscrew the button and your timing needle is in full view.

#GRE KSD0025AH **\$17.99**

**Lexan Timing Window**

Replacement lexan timing window for KSE Water Pump. Simply remove the two nuts on the top of the water pump and replace the window. O-ring replacement recommended when replacing cover.

#KSE KSD1013 **\$3.99**

**KSE Water Pump Rebuild Kit**

If your pump has developed a little leak on the bottom, your pump seal is worn out. This handy little kit allows you to rebuild your pump saving you a lot of money.

#KSE KSD1033 **\$109.99**

**Water Pump Inlet Tube**

Replacement water pump inlet tube for KSE pumps.

#KSE KSD1006 **\$19.99**

Hose & Block Mount

Simple, easy to use, just bolt to the front of your block no drilling or tapping required.

#KSE KSD1009 **\$17.50**



Kinser Filters

Becoming the most popular air filter for sprint cars. So simple to clean. Keeps engine 2 times cleaner than K&N filters and 1/2 the price of other air cleaners. Top of filter also pulls air unlike the competitors. Rubber grommets included. Accepts all brands of stacks.

Complete
 #KAF AFSET \$359.99
w/o grommets
 #KAF AFWOGROM
 \$269.99

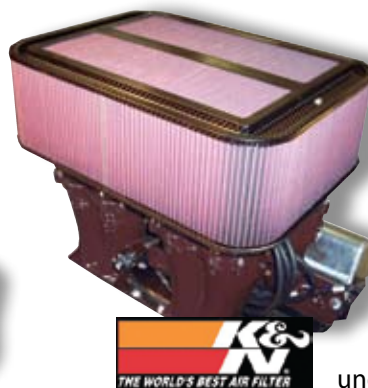

K & N Air Filter

Light weight yet durable, K&N's Sprint Car Style air box is a must for any racer currently using traditional multi-siamese stacks. Constructed from ultra-light weight carbon fiber and weighing in at just under 3-1/2 lbs, K&N's Sprint Car Style air box

provides ample air flow for your racing needs.

#KNE 100-8567 \$599.99

KINSER AIR FILTER COMPONENTS



Basket #KAF BASKET
 \$139.99



Foam
 #KAF FOAM
 \$59.99



Plate
 #KAF PLATE
 \$79.99



Grommets
 #KAF GROM \$105.99
 Set of 4



Outerwear
 #KAF OUTER \$48.99



Klotz Foam Filter Oil

K&N Filter Oil will not work on Kinser foam filters! This easy to use spray works great for protecting your motor from harmful dirt particles.

#KLO KL-606 \$7.95



K&N Air Filter Oil

A must have on K&N Filters, no matter what style. Without it, smaller particles will sneak through the screens into your engine.

#KNE 99-0516
 \$7.95

K&N Air Filter Cleaner

Specially blended to remove oil deposits & dirt from your air cleaner.

#KNE 99-0621 \$11.95



CP ASCS Piston w/Gas Ports

CP Pistons has hit a home run with their new piston

**NEW!**

for ASCS engines loaded with many options at shelf stocking prices.

Designed for Brodix Spec Head, back cut rings, wire locks, gas ports, metric ring package, back cut rings, accumulator and anti-detonation grooves, 15cc domes for max compression.
\$899.99



For over 60 years, JE Pistons has been the industry leader in forged racing pistons for Chevy, Ford, Mopar and Buick engines.

350/400 Pro Topline® / RHS® and Brodix® 11X

Specially designed to fit the Pro Topline 23° Lightning cylinder heads (Dome will also fit Brodix 11X heads) these pistons are offered in +.005" and +.010" bore sizes to accommodate new aftermarket cylinder blocks. Built for high horsepower alcohol and nitrous applications they are perfect for high rpm engines like ASCS sprint car and drag race engines. Piston accepts 1/16, 1/16, 3/16 rings.

23" Domed **\$895.00**
Flat Top **\$849.00**

**NEW!****NEW!****Maxi-Lite Crankshafts**

Developed by Crower's engineers, for the racers never ending desire for maximum throttle response, lighter rotating mass and of course reliability. This new design which combines our proven Ultra-Light and Standard Light Weight designs. Made from the world's finest 4340 chromoly steel. The Maxi-Light design comes standard; with pendulum undercutting, center counterweights removal, four lightening holes, gun drilled mains, profiled rear flange and radius edges.

Lightweight **\$2100.00**
Semi Ultralight **\$2350.00**

**Callies Crankshafts**

What more can be said about Callies than already has? Dyno testing and real world race car testing has proven to us Callie's crankshafts can take the abuse. From the MAGNUM XL 39lbs to the Race master 50 lbs Callies has what you need. Please contact us for purchase.

Starting @ \$1695.00

**NEW!****Maxi-Lite Rods**

The original tapered beam connecting rod. Crower's "RBT" (Radial Beam Technology) design combines lightweight performance with proven reliability at an extended rpm. CNC machined, vacuum degassed, and premium steel alloy rated to 170,000 p.s.i. The Maxi-Light 93 Series rods are available in six unique designs, depending on intended application, horsepower and rpm considerations. Crower pioneered the use of small journal diameters, including the popular Honda bearing size (2.008") and the Quad 4 bearing size (2.015") for reduced friction and increased horsepower. H11 tool steel rod bolts come in standard sizes, 3/8 for series 1, 2, & 3, and 7/16 for series 4, 5, & 6. Optional AMS5844 bolt upgrade available (280,000).
\$1379.00

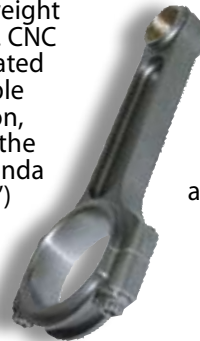
**Howards Ultimate Duty Billet Rods**

A true American billet rod at prices less than imported billets! 1000+ HP rating. American 4340 certified aircraft quality steel. American multi-phase heat-treating. American machined. Profiled for long stroke applications and weight savings. Rod caps are double ribbed for added strength. Rod cap alignment dowels to keep bearing pins. 7/16" ARP 2000 capscrew (220,000 psi) fasteners secure the caps. Chevy SB (LJ), 6.000 (670g) #HRC BR6000 **\$829.99**

Engine Block

The Little M block is the affordable alternative for serious small-block racers. Our precision machining eliminates the time and expense of 'blueprinting' a stock block. With extra-thick cylinder walls, four-bolt main bearing caps, and a competition oiling system, the Little M is the perfect starting point for a powerful and reliable engine on the race track. You can select nodular iron or steel four-bolt main bearing caps, 4.00" or 4.125" cylinder bores, and 350 or 400 main bearings. Don't waste time on a questionable junkyard block or waste money on machining a "semi-finished" factory casting. The Little M is brand-new, fully machined, and virtually ready to assemble with off-the-shelf small-block components. Available from bare block to completely machined CNC lightning also available.

Starting at \$2200.00 Options: **Lightning \$650.00**
Roller Cam Bearings \$400.00

All shipping additional

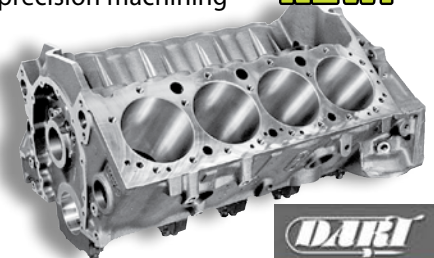
NEW!

T&D Competition Shaft Rockers

Produced with computer-aided design, then CNC manufactured to ensure precision in every application. Large diameter, deep case hardened 8620 steel shafts, along with 2024 aluminum bodies have proved these rockers to be the lightest, most efficient and most durable rocker arms available.



All T&D Machine Products available, including all options and rocker ratios.
Starting @ \$865.00



Clevite Engine Bearings

350 Mains: #M77 MS909H \$68.95
Sm Journal Rod: #M77 CB745H \$66.72
Lg Journal Rod: #M77 CB663H \$68.48
Std. Chevy Cam: #DUR CHP-8 \$25.99

Erson Cams

ERSON CAMS have dominated Top fuel drag racing for 40+ years. Why? Unsurpassed throttle quality, tunability, and reliability. Don't let your RPM's be limited by your ASCS heads.



Starting @ \$385.00

Allstar Gear Drive

This aluminum gear drive is complete with crankshaft and cam gears, needle bearing sets for the front and rear of cam gear, two camshaft dowel pins and five camshaft gear offset bushings.

#ALL 90000 **\$569.99**
Shaver/Westmar available \$569.00

This gear drive is used by some of the top engine builders in the country. When only the best will do.

NEW!



Push Rods

Comp Cams Hi-Tech Push Rods are a one-piece design and are made of a high-quality seamless 4130 chrome moly (NASCAR quality wall thickness - .080"). These push rods are heat treated to a hardness of 60 on the Rockwell "C" scale for even more strength and are finished in black oxide. The push rod length and part # is stenciled into each push rod for ease of use.

Starting @ \$119.95

Brodix ASCS Cylinder Heads

Whether you're looking for a bare unported set of castings or complete heads all tricked out with Titanium components and legal port work ready to bolt on, we've got them. Give us a call and we'll help you decide what package fits you best.

Starting @ \$1299.00

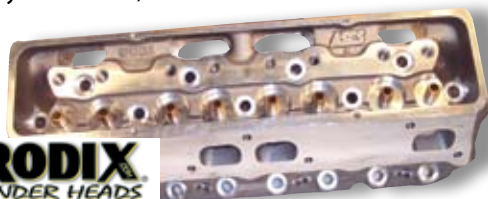

Crane Lifters

Crane Cams' mechanical roller lifters are used by motor sports' most famous and successful professional racing engine builders. Crane mechanical roller lifters are the strongest, most durable available



for engines used in competition CNC machined for accuracy. Choose from standard or new Pro-Series ultra light.
#CRN11553-16 \$549.99
PRO SERIES SHORT #CRN11548-16 \$569.99
TALL

Crower SB2 Roller Lifters

Incorporates all of the standard features of our proven roller tappet design, like carbo-nitrided body for the best possible wear resistance, a Crower designed roller bearing featuring longer needles, and a precision CNC machined one-piece body that delivers the utmost in rigidity and axle trueness. Alignment blade fastening system incorporates Crower's exclusive "orbit formed" locking

mechanism for permanent spool attachment. Available in SB2/SB2 and SB2/Standard block designs in .842", .874", .903" and .937" body diameters. Special option includes Crower's HIPO (high pressure oiling) which lubricates the axle and needle bearings for longer life. Hard chrome body option also available.
\$649.00

Total Seal Piston Rings

Total Seal's® 2 piece Gapless® Piston Rings seal the end gap with the secondary rail, virtually eliminating "Blow-By".



Total Seal pioneered this technology over 25 years ago and has been perfecting it ever since. Available for Top and Second Groove applications. Give us a call for application.

Starting @ \$279.00

**90 Deg Filter Adapter**

Provides greater ground clearance. Allows use of 2-quart truck oil filter. Avail. with 3/8 bolts for aluminum block or 5/16 bolts for iron blocks. NOTE: We recommend 3/8 bolts for all installations.
#BAR 9012 **\$139.99**

**Barnes 9017 Series Oil Pump**

Top quality materials, precision machining, solid engineering, and affordable pricing make Barnes oil pumps the choice for sprint cars. Available in 3 or 4 stage applications.

3 Stage BAR 9017-3C \$999.99
4 Stage BAR 9017-4C \$1250.00

Barnes 9117 Series Oil Pump

Barnes 9117 pumps incorporate the race-proven features of the 9017 PLUS the added performance benefits of our newest, high efficiency rotors and an oil pressure bypass and oil filter adapter machined directly onto the pump's mounting flange- to give you the easiest possible access to the oil pump, filter and pressure regulator. Available with the New 3-Lobe Rotor for high vacuum capacity
#BAR 9117-xC
Starting at \$1499.00

NEW!**Barnes Remote Oil Filter Mount**

Mounts to front of block using existing water pump bolt holes. Eliminates excess plumbing.
#BAR 8930 **\$109.95**

Barnes Pump Adapter

Just like a cam spud these drives will start to wear out. Replace yours if there's any wear before it's too late.
#BAR 029 **\$44.95**

**JOES -4 Engine Block Oil Pressure Fitting Adapter**

1/8" pipe to -4AN extra tall so you can screw into the back of the block with the manifold installed.
#JOE 42800 **\$12.99**

**Fram Sprint Car Oil Filter**

Sprint car racings most widely used oil filter.
#FRA HP4 **\$11.99**

FRAM**Barnes Block Off Plate**

Available with a -10 or -12 fitting for oil inlet or a -10 plug for filter block off.
#BAR 8910 **\$49.95**

**Pennzoil 25/50 Race Oil**

Hard to find blend used by all of the top engine builders. Sold separately or by the case.
#PEN 3623
\$4.99 Qt. / \$54.99 Case

Fibertec Carbon Fiber Oil Filter Protector

Protects oil filter from rocks or debris.
#FTC OILFCV **\$38.99**

**System 1 Oil Filter**

Ribbed Aluminum Housing, Reusable Stainless Steel Screen Element. Out flows paper elements by as much as 6 times. Pays for itself in just 8 races.
#SYS 209-51261 **\$163.99**



NEW!



Saldana 2 Piece Cleanable Vented Dry Sump Tank

Brand new Cleanable Internal Breather Dry Sump Oil Tank. 26" tall and available with a -16 return or 2-12 returns. 1" tube exiting the bottom of the tank which eliminates the need for crossover tubes on the engine. Bolted together to make cleaning the tank inside possible.
SAL OT626SLHIB-xx
\$339.99

Saldana Vented Dry Sump Tank

Available with or without internal breather, simply the most finished oil tank out today. Standard with two inlets. Custom tanks available.
#SAL OT624SRH 2-Piece **\$299.99**
#SAL OT626LH1B 2-12 Returns **\$283.99**
#SAL OT626LH1B1 1-16 Returns **\$283.99**



Dan Olson Oil Pan

Duarable, light, shiny, and welded to perfection. The best looking oil pan available. Sold with 2 or 3 outlets.
#DOP OP2 **\$625.99**
#DOP OP3 **\$656.99**

-4 x 24" Oil Pressure Line

Choose between the ULTRA LIGHT Kevlar Goodridge and the stainless braided line.
#GDR K310424BK **\$28.95**
#BKL 4-24-ST **\$15.00**

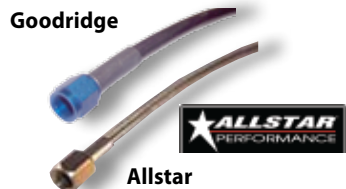

LRB 2 Piece Front Engine Mount w/Oil Tank and Barnes Mount

The nicest front engine mounts on the planet! Black anodized with oil tank brackets installed and optional Barnes filter mount holes. Securely holds oil tank in exactly the right place for all modern chassis. Price includes all oil tank mount hardware and both front engine plates.
#LRB FMMOT
\$147.99



1 Piece Front Motor Mount

Anodized black. Fits all modern chassis and engine blocks.
#KRP 1500 **\$69.99**



Winters Dry Sump Tank Mount

A must have with the new 2 piece front motor mounts. Bolts directly to motor mount and holds dry sump tank secure in car tight against engine for easy plumbing. Sold separately, but both are needed.
Upper #WIN 3981 **\$49.99**
Lower #WIN 3982 **\$49.99**



Oil Tank Heater

A simple way to preheat your oil with no welding or fitting.
#MOR 23995 **\$71.99**



Oil Preheater

Will heat 8 quarts of oil to 100° in approx. 20 minutes. Weldable bung for oil tank placement with STD 110 volt power cord. Engines will live much longer on consistent temperature oil.
#MOR 23980 **\$77.99**

ENGINE

Saldana Cross Flow Radiator

This new radiator is what all of the outlaw boys use. No airbox is needed. Just mount this directly to the logo tabs on your frame & you're done! Fits nicely under low scoop hoods, too! Comes complete with welded aluminum tube.
#SAL SRS15CFC **\$339.95**



New PMP Cross Flow Radiator

All 07 and later PMP chassis accept this new cross flow radiator just like the newer sprint cars. Dzuses directly into the chassis and sits perfectly under the hood to accept all of the air the car can grab.
2 Row #SAL CFMSZRW **\$339.99**
Single #SAL PMPRAD **\$319.99**
Available with fittings or push-on bungs.



NEW!

New thicker option for better cooling



Super Light Sprint Radiator

Only 9.1 lbs. full of water! Cools as good as double core radiators. Awesome way to lose weight!
#SAL SRS15LM **\$312.99**

NEW!



FSR Engine Mount Radiator Kit

New from FSR this year. A complete radiator system that bolts directly to the motor. Cross Flow design for increased cooling and supplied with all necessary components to hook directly up to a KSE water pump system. -10 Oring Boss Fittings lined up on the right side. Complete with all brackets and hoses.
#FSR 1105 **\$459.99**

SpeedMart



Honeycomb Radiator Protector

The cheapest way to protect your radiator from mud & rocks. Weighs 13 ounces. Great insurance!
#SMI HC1 **\$29.95**
#SMI HC12 **\$29.95**

Royal Purple Ice

Purple Ice is a high performance, synthetic, radiator coolant additive. It reduces engine heat by reducing the surface tension of the radiator fluids for improved heat transfer. Purple Ice fosters optimum coolant flow by helping to prevent formation of scale deposits in the radiator. It also lubricates the water pump seals.
#ROY 1600 **\$14.99**

NEW!



Standard Sprint Deluxe Radiator

With 4 1/2" NPT inlets and a 1 1/2" outlet. Cools better than any other sprint radiator.
#SAL SRS15V **\$285.95**

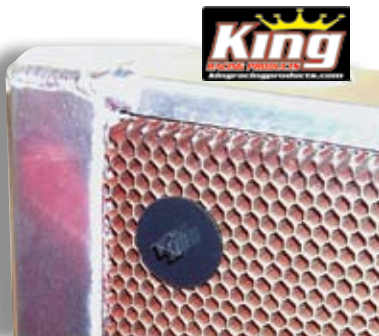

NEW!

Radiator Honeycomb Mounts

A simple little kit that is worth having. Mounts your honeycomb to the radiator so it won't slide down or fly out!
#KRP 2625 **\$14.99**

Water Wetter Super Coolant

Tired of overheating? Dyno tests prove-one bottle will drop motor temp 25 deg immediately. Also prevents premature corrosion.
#RDL WW **\$10.95**



Winters 2 Piece Front Motor Mount

With the increased torque of today's engines, a simple 1 piece front motor plate will not hold the engine secure in the car. 2 piece front motor plates bolt to both the top and the bottom holes on the block stabilizing it in a crash. Oil tank mounts directly to them as well.
#WIN SC2825 **\$74.99**



Lower Radiator Hose

Available in stock for cross flow and standard radiators. Both configurations will adapt to The Hot Setup or other engine heaters.
Cross Flow
#CQT 20442 **\$23.99**
Standard Radiator
#CQT 20753 **\$23.99**



JOES Freeze Plugs

These Freeze plugs work great for reverse cooling your motor. #8 AN fitting
#JOE 36200 **\$21.99**

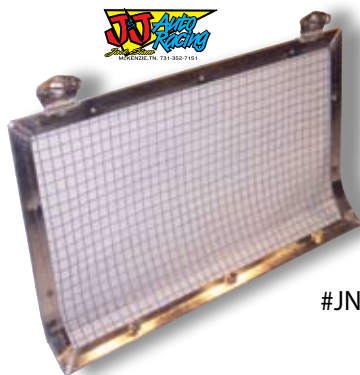

Rocket Radiator Mudd-Off Screen

This handy aluminum screen keeps all of the big chunks of mud out of your cooling system. Dzus holes for easy application.
#JNJ 101024K **\$47.99**

Rocket Radiator Tray

Dzus right into your chassis will fit all newer model chassis.
#ROC PNLRTRAY **\$32.95**



Rocket Aluminum Front Air Box

Heavy Duty. Dzus right into name plates on late model cars.
#ROC PNLABOX **\$49.95**



Radiator Ramp

Radiator ramps do two things: Create down force so your car turns easier at the end of the straightaway and force more air through the radiator cooling your engine more efficiently.
#FTC ADAM **\$85.95**
#ROC PN RAMP **\$59.99**



Aluminum Radiator Fittings

We've got just about every size imaginable.
Check out our fitting section on pages 65-66



Sprint Radiator Cap

Specially rated for racing radiators and high horsepower motors. Mini caps available, too!
29-31 Lbs. #ALL 30128 \$19.99
22-24 Lbs. #ALL 30127 \$16.99
Mini (31 lbs.) #SAL RAC-005 \$22.95





NEW!

Spintech Sprint Car Headers
Swept forward headers are on average 10"-12" shorter than standard swept back headers without sacrificing collector length. This allows more room for bigger mufflers without having to sacrifice torque and horsepower. Collector Merge Cones by SPINTECH More Efficient exhaust flow MORE POWER. SPINTECH's have perfectly timed collector firing order on both sides, and nearly equal length. This produces more horsepower, more torque and a broader powerband. Dyno tests have proved over 10 HP gain with Spintech Headers
1-3/4" TO 1-7/8" to 2" Step with 3-1/2" Collector or Std. 1-7/8 or 2"
#SPN HXT **\$379.99**

Straight Tube Headers
20 horsepower gain on any engine dyno! 2 lbs. lighter. Ideal for open header tracks or small muffler applications.
Std. \$219.99
Step \$249.99

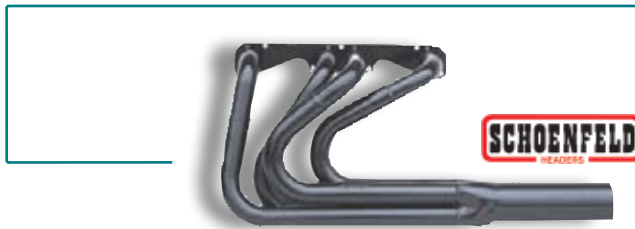

Swept Forward Spread Port Headers

Swept forward design for muffler clearance. Eliminates burning your left rear tire in the pits.
Std. \$199.95
Step \$249.95

NEW! Straight Tube Headers that fit BIG mufflers!
Part numbers followed by a RED "S" indicate a special/ custom header. (Add \$20.00)

TUBE DIAMETER	COLLECTOR DIA/LENGTH	STANDARD CHEVY	SPREADPORT Down Nozzle	ALL PRO	PRICE
Straight Tube Headers					
1 3/4"	3 1/2" - 13"	1054L	1054LSP	-----	209.99
1 3/4" - 1 7/8"	3 1/2" - 13"	1054LV	1054LVSP	-----	269.99
1 7/8"	3 1/2" - 13"	1055L	1055LDNS	1055LAP	239.99
1 7/8" - 2"	3 1/2" - 13"	1055LV	1055LVDNS	1055LVAP	289.99
2"	3 1/2" - 13"	-----	1056LDN	1056LAP	219.99
Swept Forward Headers					
1 3/4"	3 1/2" - 13"	1024L	1024LSP	-----	219.99
1 3/4" - 1 7/8"	3 1/2" - 13"	1024LV	1024LVSP	-----	269.99
1 7/8"	3 1/2" - 13"	1025L	1025LDN	1025LAP	219.99
1 7/8" - 2"	3 1/2" - 13"	1025LV	1025LVDN	1025LVAP	269.99
2"	3 1/2" - 13"	-----	1026LDN	1026LAP	219.99



King Muffler Clamp Kit
Used by all of the outlaws and traveling teams. They make changing mufflers or headers so easy and can be reused if necessary. Made from sturdy stainless steel for no failures.
#KRP 2111 **\$82.99**



King Muffler Clamp
Don't forget a spare muffler clamp when putting your spares together.
#KRP 2110 **\$39.99**

Header Gaskets
Available for spread port or standard port heads. Sold in pairs.

- All Pro** #FEL 1445 **\$29.99**
- Spread Port** #FEL 1409 **\$22.99**
- Std Port** #FEL 1426 **\$23.99**

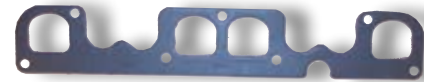

All Pro



Spread Port



Std Port



King Weld on Flange
These come in handy when welding up a spare set of headers.
#KRP 2115 **\$42.99**

Spark Plug Deflectors
Don't let a rock knock you out of a race. Use these to protect your spark plugs and nozzle lines.

Straight Tube Headers



- #HRP 8336LH **\$11.95**
- #HRP 8336RH **\$11.95**



Spin Tech's LW Muffler Assortment

The Pro name is just what these sound like, the purest of the pure racing muffler. These mufflers are for all out racing where sound requirements are very liberal. These patented mufflers are compact and light weight, yet still very effective.
#SPN 4543 **\$102.95**
#SPN 454-PRO **\$102.95**



Sprint Car Box Muffler
The industry's most popular quiet muffler. Passes all DBA rules on the stringent west coast. Easy to mount, clears everything on the car with swept forward headers. Size 4" x 8 1/2" x 12".
#SPN 1555 **\$113.95**



Swept Forward Headers

- #HRP 8329LH **\$10.99**
- #HRP 8329RH **\$10.99**



Exhaust Port Block Off Plates

Great for engine storage.
#HRP 0916 **\$20.99 set**



Exhaust Turndown
Used if fumes or noise are an issue. Slip onto headers or tack on mufflers to eliminate both.
#SCH 3525 **\$18.99**



Outlaw Muffler (100Db@100ft)
The most common muffler in sprint racing. Almost no horsepower loss.
#SCH 112535 **\$32.99**



ARP Cam Seals
Standard Block
 #ARP 934-0007 \$29.99
Dark Block
 #ARP 934-0008 \$29.99



1 5/8"
 overall
 length



ARP Cam Spud

If the survivability of your camshaft drive has been a concern, ARP's cam spud should put your mind to rest. These spuds are bulletproof!
 #ARP 934-0005 \$29.95



Intake Gaskets
 #FEL 1266 \$29.99
 Extra Thick for Hilborn 1 Piece manifolds. Trim to fit.
 #FEL 1263 \$25.99



Intake Gaskets
 #FEL 1206,1207,1209 \$24.99



Valve Cover Gasket
 Thin paper gaskets never stop leaking, Cork gaskets blow out. These thick rubber, metal inner liner gaskets stay in place, don't leak, and last forever.
 #FEL 1628 \$63.99



Fel Pro One Piece Pan Gasket

A great alternative to the O.E. four piece design. No leak paths and no cutting required. Rigid steel side rail carriers for easier installation. Specially formulated high-heat Fel Pro Silicone Rubber. No chemicals required!
 #FEL 1882 \$48.99



Rear Main Seal
 Nothing worse than a leaky rear main seal. Fel Pro Designed this one to take the abuse of dirt, heat and the high vacuum created by dry sump engines.
 #FEL 2912 \$29.99



MLS Head Gasket

Fel Pro's Multi layer steel Head gaskets are made for the abuse of today's high compression engines. Won't mark heads like regular head gaskets saving you money on resurfacing your heads every year.
 #FEL 1142 \$84.99



Head Gasket

The old stand by. The most widely used head gasket. Excellent sealing and durability.
 #FEL 1003,1004 \$44.99
 #FEL 1010 \$52.99

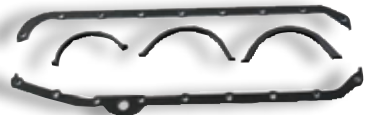

Oil Pan Gasket

Tired of trying to find the correct pan gasket? We've got it!
 #FEL 1821 \$30.99



Precision Tool Room Valve Springs

These are the best valve springs for sprint cars. They will withstand the 8500 plus RPMs and still last all season! \$449.99

Part #	Type	Color Code	O.D.	L.D.	Seat Pressure	Open Pressure	Rate per Inch	Coil Bind	Max Net Lift
ISK9965	Dual w/ Damper	Gold	1.560"	.740"	245 lbs @ 1.950"	585 lbs @ 1.270"	470	1.170"	.680"
ISK9985	Dual w/ Damper	Gold	1.560"	.740"	245 lbs @ 2.000"	600 lbs @ 1.300"	500	1.200"	.700"



Valve Spring Changer

LSM developed the standard for changing valve springs with their innovative design. The LSM Spring Removal Tools are simply the best quality, and easiest to use. It makes changing valve springs a fast and simple one-man job.
#LSC 100 \$238.99



Valve Spring Height Checker

#PFM 66902
\$59.99



Valve Lash Tool

This awesome tool gives you an extra hand when adjusting your valves. No toolbox is complete without one. Specify sizes for wrench and Allen when ordering.
#ALL 9640X \$34.99

NEW!



Liquid Filled Leak Down Tester

The only leak down tester sold with a liquid filled gauge. Ever notice when you leak your motor down, the needle is shaking or hard to locate. Liquid filled gauges are the only way to prevent that. Sold complete with 2-18" x 3/8" hoses.

One with a #6 female for barrel valve and one with a 14mm o-ringed spark plug adapter for leaking down the cylinders.

#KRP 1910 \$151.99



Feeler Gauge Handles

Full-Bore Race Products has come up with an inexpensive set of feeler gauge handles to compliment our E-Z Wrench Valve Adjuster Tool. Each set comes with 2 handles, one marked "EX" (exhaust) and the other "IN" (intake). Put your own feeler gauge blades in the handles according to your cam manufacturers specifications and they will always be ready when you are.
#FBR 234-A \$18.50



Economy Valve Spring Checker

The ideal tool for checking valve seat pressure on an assembled engine.

#MOR 62391 \$101.99



Engine Pulling Strap

Simply the easiest way to change a motor today. Top teams have one attached to the spare motor in the trailer, too!
#CRO 11645 \$19.95

Oil Filter Cutter

Cut your old filter open to spot problems before they cost you an engine.
#LON 77750 \$52.95



Engine Box

Used by all major engine builders to store and ship engines.
#SCR 5108 \$214.99



HRP EZ Store Motor Stands

Simply the best motor stands made. Tubular structure so they slide easy. Stores in 18" x 8" x 1" when not in use. No sharp edges to scratch trailer floor.

#HRP 6002 \$69.99

FITTINGS



AN Caps and Plugs			
Size	Cap	Plug	Port Plug
#3	\$2.99	\$2.99	\$2.50
#4	\$2.99	\$2.99	\$2.99
#6	\$3.99	\$2.99	\$3.99
#8	\$4.99	\$3.99	\$5.99
#10	\$5.99	\$4.99	\$6.99
#12	\$7.99	\$5.99	\$8.99



Hose End for Steel Braided Line						
Size	Straight	45°	90°	120°	150°	180°
#4	\$8.75	\$20.50	\$20.50	X	X	X
#6	\$9.30	\$22.10	\$22.99	X	\$27.80	\$27.80
#8	\$11.50	\$25.95	\$25.95	\$31.95	\$31.95	\$31.95
#10	\$14.95	\$30.70	\$30.70	\$35.95	\$35.95	X
#12	\$20.50	\$36.95	\$36.95	\$39.99	X	X
#16	\$32.75	\$48.95	\$48.95	X	X	X



Pre-made Stainless Steel Flex Line Chart

Size	Length	Fittings	Part #	Price
#3	5"	St.	BKL 3-5	\$12.99
#3	15"	St.	BKL 3-15	\$14.99
#3	16"	St.	BKL 3-16	\$14.99
#3	18"	St.	BKL 3-18	\$14.99
#3	21"	St.	BKL 3-21	\$14.99
#3	21"	St. 90	BKL 3-21-90	\$19.99
#3	24"	St.	BKL 3-24	\$14.99
#3	24"	St. 90	BKL 3-24-90	\$19.99
#3	28"	St.	BKL 3-28	\$19.99
#3	30"	St.	BKL 3-30	\$19.99
#3	36"	St.	BKL 3-36	\$19.99
#3	48"	St.	BKL 3-48	\$24.99
#4	12"	St.	BKL 4-12	\$15.00
#4	15"	St.	BKL 4-15	\$15.00
#4	16"	St.	BKL 4-16	\$15.00
#4	18"	St.	BKL 4-18	\$15.00
#4	18"	St. 90	BKL 4-18-90	\$19.99
#4	20"	St.	BKL 4-20	\$15.00
#4	22"	St.	BKL 4-22	\$15.00
#4	24"	St.	BKL 4-24	\$15.00
#4	28"	St.	BKL 4-28	\$15.00
#4	36"	St.	BKL 4-36	\$19.99

Pipe Plugs	
Size	Price
1/8"	\$3.99
1/4"	\$3.99
3/8"	\$4.99
1/2"	\$4.99
3/4"	\$5.99

Tube Nut & Sleeve Chart		
Size	Tube Sleeve	Tube Nut
#3 (3/16)	\$1.29	\$1.29
#4 (1/4)	\$1.29	\$1.29
#6 (3/8)	\$1.99	\$1.99

Couplings	
Size	Price
1/8" F	\$3.99
1/4" F	\$3.99
1/8" M	\$2.99

Reducer Pipe Bushing		
NPT Size	NPT Size	Price
1/8"	1/4"	\$4.99
1/4"	3/8"	\$4.99
1/8"	3/8"	\$4.99
3/8"	1/2"	\$4.99
1/4"	1/2"	\$5.99
1/8"	1/2"	\$5.99
1"	3/4"	\$14.99
3/8"	3/4"	X

AN Female Swivels	
Size	Price
#4	\$7.99
#6	\$7.99
#8	\$8.99

Male Union	
Size	Price
#3	\$3.99
#4	\$3.99
#6	\$4.99
#8	\$6.99
#10	\$7.99
#12	\$12.99

90 Deg Elbow	
Size	Price
#3	\$8.99
#4	\$7.99
#6	X
#8	\$11.99
#10	X
#12	X

Male Flare Tee	
Size	Price
#3	\$9.99
#4	\$9.99
#6	\$9.99
#8	\$15.99
#10	\$20.99
#12	X



Push On Hose End Fittings					
Style	#4	#6	#8	#10	#12
Straight	\$5.99	\$5.99	\$7.99	\$8.99	\$14.99
45 Deg	\$15.99	\$19.99	\$23.99	\$24.99	\$27.99
90 Deg	\$15.99	\$16.99	\$20.99	\$23.99	\$27.99
120 Deg	X	\$20.99	\$26.99	\$29.99	\$34.50
150 Deg	X	\$21.30	X	\$29.99	\$34.99
180 Deg	X	\$19.99	\$24.99	\$25.99	X

AN Port to Flare Fittings		
AN Port Size	Flare Size	Price
#10	#4	X
#6	#6	\$9.99
#6	#8	\$11.99
#8	#6	\$11.99
#8	#8	\$11.99
#8	#10	\$14.99
#8	#12	\$10.99
#10	#6	\$9.99
#10	#10	\$18.99
#10	#12	\$18.99



Pushlock Hose	
Flare Size	Price
#4	\$3.50
#6	\$3.75
#8	\$4.00
#10	\$4.25
#12	\$5.95

Price per Foot



Stainless Steel Braided Hose	
Hose Size	Price
#6	\$6.50
#8	\$8.25
#10	\$9.50
#12	\$10.50
#16	\$13.95

Price per Foot

Adapter Tee Pipe on Run		
Size	Pipe	Price
#3	1/8"	\$12.99
#4	1/8"	\$11.99
#6	1/4"	X
#8	3/8"	\$17.99
#10	1/2"	\$18.99



Adapter Tee Pipe on Leg		
Size	Pipe Size	Price
#3	1/8"	\$10.99
#4	1/8"	\$9.99
#6	1/4"	X
#8	3/8"	\$17.99
#10	1/2"	X



Male Flare to NPT Pipe Fittings				
Flare Size	Pipe Size	Straight	45 Deg	90 Deg
#3	1/8"	\$3.50	\$8.99	\$8.99
#4	1/8"	\$3.50	\$8.99	\$8.99
#4	1/4"	\$3.99	X	\$8.99
#6	1/8"	\$4.99	X	X
#6	1/4"	\$3.99	\$8.99	\$8.99
#6	3/8"	\$3.99	\$11.99	\$12.99
#6	1/2"	\$5.99	\$18.99	\$19.99
#8	1/4"	\$5.99	X	X
#8	3/8"	\$5.99	\$10.99	\$10.99
#8	1/2"	\$5.99	\$17.99	\$16.99
#10	3/8"	\$6.99	X	\$18.99
#10	1/2"	\$6.99	X	\$17.99
#10	3/4"	\$10.99	\$24.99	X
#12	1/2"	\$10.99	X	\$25.99
#12	3/4"	\$10.99	\$24.99	\$25.99



Tee Male Flare Swivel on Leg	
Size	Price
#3	\$30.99
#4	\$14.99
#6	\$17.99
#8	\$25.99
#10	X
#12	X

Tee Male Flare Swivel on Run	
Size	Price
#3	\$31.99
#4	\$15.95
#6	\$19.99
#8	\$27.99
#10	X
#12	X

Wing Port Fitting	
Size	Price
#6	\$14.99

Bulkhead Nuts	
Size	Price
#3	\$1.99
#4	\$1.99
#6	\$1.99
#8	\$2.99
#10	\$2.99
#12	\$2.99

Bulkhead Fitting						
Style	#3	#4	#6	#8	#10	#12
Straight	\$4.99	\$4.99	\$5.99	\$7.99	\$11.99	\$14.99
45 Deg	\$9.99	\$6.99	\$8.99	X	X	X
90 Deg	\$9.99	\$7.99	\$9.99	\$14.99	\$18.99	X



Tough Because?

This pump can ingest dirt and spit it out that would fail any other pump.... Twelve 10-32 studs holding the rigid cover plate in place decreasing pump body flex, larger bearings that will exceed any RPM's you put to this pump, direct flow to the gears that eliminate pump cavitations, Case Hardened precision Ground gears and shafts, Hard Coated Housing, Snap ring to prevent seal blowout, bolt on fittings and manifolds to eliminate leaks. Available in the traditional 400 thru 500 sizes
\$960.99

NEW!

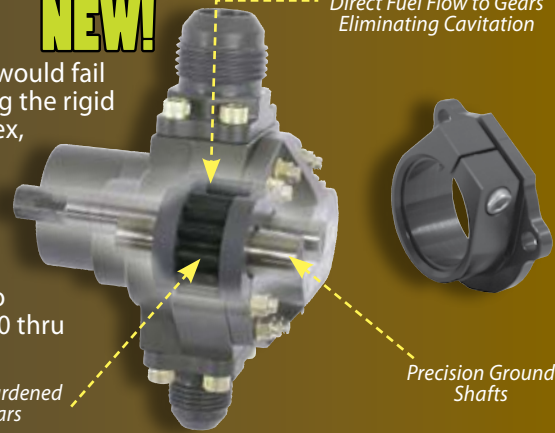

Direct Fuel Flow to Gears
Eliminating Cavitation

Case Hardened Gears

Precision Ground Shafts



Fuel Pump -6 Fitting
 -6 Port to -6 Flare fitting for return side of all fuel pumps.
 #XRP 980006 **\$9.99**



Non Gumming Fuel Pump Lube

Use on your entire fuel system. WD-40 and other store bought lubricants will gum up inside of the pump, losing accuracy. Easy to use in tight cockpits and in the barrel valve of the injector.
 #WAT LUBE **\$8.99**



Kinsler Swivel Flange

Very important to have when you switch fuel pumps between cars. It takes too much time to tighten the 3-1/4" bolts into the flange, and they are easily stripped out junking your power steering pump. (Sold for Waterman and Kinsler Pumps)
 #KIN 2903 **\$71.99**



Fuel Pump Inlet Fitting

-8 Port to -12 Flare. Very hard to find! Make sure you have one.
 #PET 15-1077 **\$10.99**

Fuel Pump Inlet Fitting With Returns

Substitute this inlet fitting for the standard one and it allows you to plumb the fuel pump back to the filter or the tank without a fuel block. You can even return the lines right back to the pump and mount the pill cans on the manifold of the pump saving tons of mess and weight.
 #DSR 1504 **\$51.99**



Kinsler Manifold Fuel Pump

The Kinsler Manifold Sprint Fuel Pump is engineered to withstand the punishment of competitive Sprint Car Racing. This fuel pump is designed and machined from forged aluminum and houses machined steel shafts and precision lapped gears. Each fuel pump is equipped with a swivel flange mount. After mounting the fuel pump, the flange clamp bolt can be loosened to allow for easy rotation and alignment of your fuel pump. Simply re-tighten the flange clamp bolt once the fuel pump has been properly positioned. Over the past several years great advancements have increased cylinder head efficiency by 25% to 35%. Shouldn't your fuel system deliver an additional 25% to 35% in fuel volume to complement these increases? The Kinsler Manifold Fuel Pump is designed for ease of plumbing. The 500 pump has a 4-port return to allow you to plumb in a second high speed; a trick used by all the Outlaw teams.

- #KIN 2913-M3P \$639.99 400
- #KIN 2955-M3P \$639.99 450
- #KIN 2917-M4P \$649.99 500 4-Port

Fittings not included

Fitting Kit: #KIN K-PFM \$31.99
 (add \$9.95 for 4-port 500 Pump)

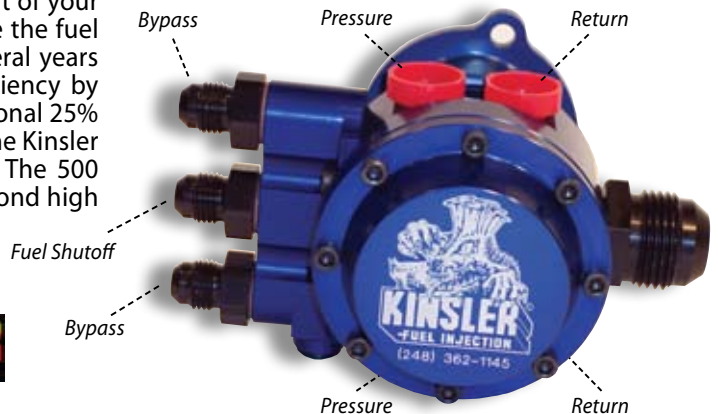



NEW!

FUEL



SpeedMart's New Complete Fuel System

We get requests for fuel system plumbing advice all of the time. We have done one better. We have built a complete plumbing system with all of the fittings, pill cans, line, steering bracket, fuel shutoff, fuel filters and brackets. -8 back to tail tank with the union to go in tank plate. -12 from tank to pump. (Fuel pump must have manifold to work.) Kinsler Quick Release Pill Can, Kinsler Diaphragm High Speed, and Kinsler Brass Low Speed Pill Cans Included. Peterson -12 Fuel Filter with Shutoff Included. King Racing Top Steering Plate, Peterson -6 to -8 Fuel Block, SpeedMart Fuel Shutoff and Flight -6 Inline Fuel Filter are all included! We will ship this to you in pieces or fully assembled. #SMI K-FSK **\$989.99** Available in blue or black hose



Standard Fuel Shutoff



Looking for an economical fuel shutoff? We found one. Will mount to your aluminum dash or to the incorporated steering gear mount featured on page 119 in our catalog.

#BCC DMFV **\$45.99**

Positive Locking Fuel Shutoff

DSR's -6 male fuel shutoff has the best detent on the market. Won't vibrate on or off in a race or while traveling. Available in fuel pump mounting style or inline.

Pump Mount Shut-Off

#DSR 1200 **\$95.99**

In-Line Shut-Off

#DSR 1201 **\$95.99**



-6 Inline Ball Valve Fuel Shutoff

The simplest, lightest fuel shutoff made. No extra fittings, just push your hose on each side. Awesome lever feel for driver. Also available in -6 male screw on fittings.

-6 AN #PET 09-0900 **\$103.99**

-6 P/L #PET 09-0902 **\$103.99**

Tank to Pump Fuel Shutoff

Push on -12 shutoff designed to shut main fuel line off for pump changing and safety. No extra fittings needed to save weight.

#PET 09-0962 **\$109.99**



Peterson
FLUID SYSTEMS

100 micron



Peterson Inline Fuel Filter w/Shutoff

Designed to go between the tank and the fuel pump. Cleanable stainless steel screens and hard anodized for methanol compatibility. Most local racing series require an additional fuel shutoff and this combines it with your filter.

#PET 09-0627 (w/shutoff) \$157.99

#PET 09-0622 (w/o shutoff) \$122.99

TECH TIPS

Fuel Filters:

Many fuel filters are referred to as a particular "micron" size. What this refers to is a size of particle that is allowed to travel through the filter. The size of the particle is also determined by the speed it is traveling through the filter. We have carefully calculated the micron we sell in each of our filters to give you the maximum protection. Below are the micron sizes we sell in our filters.

Methanol

Pressure side of pump = 140 Micron

Inline side of pump = 100 Micron

In tank filters = 60 Micron

Gasoline = 45 Micron

140 micron

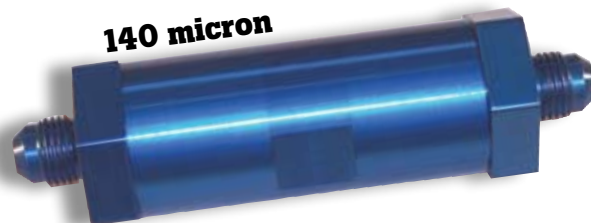

-6 Inline Flight Fuel Filter

The most economical fuel filter on the market. Perfect for filtering your fuel between the pump and the motor. Keeps nozzles super clean.

#FLI CB-6AN \$39.99

Also great for mini sprints!

60 micron



Paper Fuel Filter Element

Paper Element Separate #FRA CG27 \$12.99



100 micron

mpd
racing



Stainless Fuel Filter Element

Reusable and cleanable filter element for MPD black and blue filter. Paper filters last only a few cleanings, but these last forever.

#MPD 073200 \$40.99

Peterson In Tank Fuel Filter

Eliminate the hassle of cleaning your inline filter. Install this one in the tank and forget about it. The fuel in the tank sloshing around will keep particles from residing in the filter.

Straight #PET 09-1460 \$59.99

90 degree #PET 09-1461 \$75.99

(recommended for Outlaw style tanks)

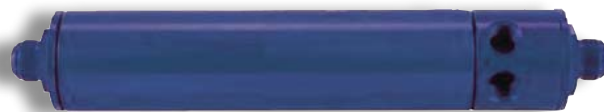

mpd
racing

MPD Fuel Filter

The industry standard for years! Sold with a paper filter installed.

#MPD 072512 \$82.99

4-Port Clamp on Fuel Block

This Fuel Block clamps to any 1.375 frame tube vertical or horizontal. It comes with three -6 fittings, one -8 fitting, one -8 plug. If running a second high speed, you can remove the -8 plug and install a -8 90 deg. fitting. Flow through design. Made from 6061 Billet Aluminum. Anodized Black. #LRB FB-BLK **\$120.00**



DSR Fuel Systems

DSR Secondary Pill Cans

Set at 35 PSI at the factory for low speed pressure relief. #DSR 1063 **\$72.99**



DSR High Speed Pill Cans

Pre set for hi-speed pressure relief and comes complete with jet. These are set at the factory, but if you have a special pressure you'd like it set at, we'll do it for you in house. #DSR 1060 **\$72.99**



DSR Fuel Systems



King Fuel Block

This very cool fuel manifold is loaded with options! With 4 -6 A/N ports and 1 -8 A/N port you can now run a Main jet can, Secondary By Pass and two High Speeds. Fuel bench tested with No fuel pressure or volume change. Hard anodized for an awesome look! #KRP 1930 **\$89.99**

Peterson
FLUID SYSTEMS



Peterson -8 to -6 Fuel Block

Awesome piece! This compact fuel block is hard anodized for a truly finished appearance. Keeps fuel lines close together. 2-3/16" holes for mounting to motorplate or kickpanel. #PET 10-0041 **\$99.99**

Kinsler Quick Disconnect Pill Holder

Used by everybody to make main jet changing a snap. #KIN 3112 **\$79.99**



Kinsler's Ultimate Hi-Speed Bypass

Absolutely the best hi-speed bypass on the market. Expensive, but worth every penny. Reduces all fluctuations in fuel flow leading to maximum fuel efficiency and horsepower. Dyno proven, and used by all of the Outlaws. Adjustable from 72-152PSI. #KIN 3972 **\$459.99**



Kinsler Diaphragm Pill Holder

Engineered for hi flow and super accurate. Allows you to adjust pressure without disassembly. #KIN 3904 **\$129.99**



King IRL High Speed Mount

Finally a mount for this hard-to-locate high speed. Bolts to the high speed and tie wraps or hose clamps to the car. Anodized black and VERY light. #KRP 2605 **\$15.99**



NEW!

SpeedMart
gettin' it done fast



Jet, Spring & Shim Kit

Now there is a jet kit to make most of the changes needed to your fuel system. Kit includes 20 Kinsler K-jets from 50 to 88 in increments of 2 as well as 5 Kinsler bypass springs (.028,.032,.036,.039, and .042.) All in a nice plastic case. Perfect starter kit!

#SMI A-KJETBP **\$239.99**



KINSLER
FUEL INJECTION

Kinsler Flowed Jets

The only jets worth having. Available in .002 increments and computer flowed for accuracy.

#KIN K-XX **\$9.99 each**



NEW!

King Super Flow High Speed Tester

Made for today's High Pressure Fuel Systems. This is the most accurate gauge you will ever find. The Extra Large 4" Gauge goes up to 160 lbs. With the Billet Aluminum Distribution Block and the Easy Flow Handle, there's no guessing if your high speed is right.

#KRP 1900 **\$179.99**



KINSLER
FUEL INJECTION

Kinsler Jet Holder

Easy rotation for choosing jets quickly. See through view window allows you to see the numbers on the jets through the holder.

#KIN 3720 **\$19.99**



SpeedMart
gettin' it done fast

King Billet Down Nozzle Filter Set

The little filters get broken because they hang out in the open on the side of the head. Without them dirt can get up into your motor. Have one or two in your tool cart in case. Sold in set of 8.

#KRP 1990 **\$79.99**



King
FUEL PRODUCTS

Injector Nozzles

Available from Hilborn, Kinsler, or Engler. All sizes and lengths available.

Call for pricing

HILBORN
FUEL INJECTION



Bypass Spring & Shim Kit

Here is a kit that includes many of the springs and shims needed to adjust your fuel system pressures. Kit includes: Kinsler By-pass springs .028,.032,.036,.039, and .042. Kinsler shims 2).183, 4).030, and 8).020. All in a nice plastic case.

#SMI A-BPK **\$39.95**

Nozzle Lines

We stock MANY different lengths of nozzle lines to replace yours as they get hard to tighten or the lines get frayed. Available for Kinsler or Hilborn. Prices vary based on lengths and fittings. Call for price and availability.



HILBORN
FUEL INJECTION

Pre-2008 Fuel Tank Plumbing Diagram

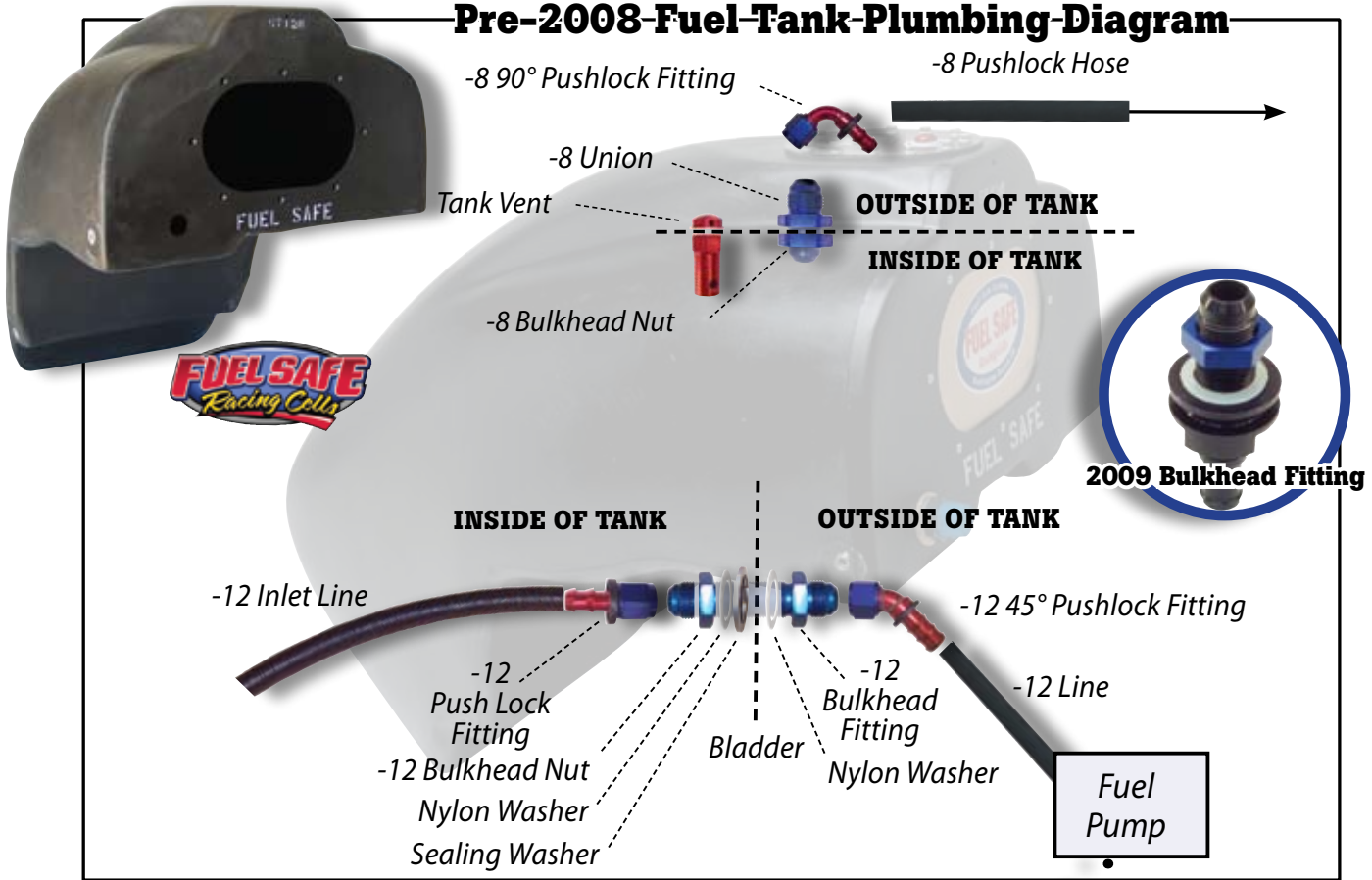

Saldana 28 Gallon Sprint Tank

Double seams for added strength, stronger hose mounting, better nut ring adhesion, better manufacturing techniques make Saldana tanks a good choice for your race team. Same mounting as Fuel Safe and -12 pickup in stock upper location.

#SAL OS228-BT **\$1429.99**
Shell only
 #SAL OS-28 **\$349.99**

See page 68 for SpeedMart Complete Fuel Plumbing System!



Our most popular fuel funnel Scribner D-Shaped Fuel Funnel

Used by all the top teams and legal at all racetracks.
 #SCR 6110X **\$15.99**



5 Gallon Jug

Available colors in stock: clear, red, blue
 #JAZ 10-015-xx **\$26.99**



D-shaped Scribner Fuel Funnel Filter

SpeedMart filters its fuel twice before ever distributing it, does your local provider? Very cheap insurance for your expensive motor! Fits D-shaped fuel funnel.
 #SCR 6119 **\$5.95**

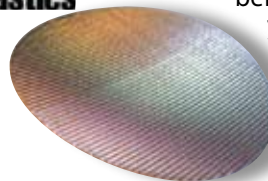



Sprint Outlaw Fuel Tanks

Designed to fit all major brand sprint cars. These wide body tanks carry fuel forward to distribute weight more evenly.

- #FUE SB225 25 gallon complete \$1485.99
- #FUE SB228B 28 gallon complete with baffle \$1676.99
- #FUE ST125 25 gallon Shell \$306.99
- #FUE ST128 28 gallon Shell \$342.99
- #FUE SB230AT-B 30 gallon \$1847.99
- #FUE ST130 30 gallon Shell \$387.99



Accessories

- #FUE SFP240 Fuel safe top plate complete \$212.99
- #FUE SFC300 Fuel Cap \$122.99
- #FUE TV6 Tank Vent \$44.99
- #FUE BH12K -12 Bulkhead Assembly \$52.99
- #FUE FP183 -12 Pick-up Line \$86.99
- #FUE 1GAS98 Top Plate Gasket \$10.99
- #FUE CP6X10 6x10 Cover Plate \$54.99

Fuel Safe Seal Kit

- #FUE A-SEALKIT \$19.99



Titanium Top Plate Bolt Kit

Every bolt you need to bolt the top plate to your tail tank. A great place to save weight because the bolts are placed high on the car
#AST 5408KIT \$61.99



Tail Tank Mount for Trailer Wall

Mounts an Outlaw tank in 4 spots for easy storage.
#HRP 6781 \$74.99



JOES Top Fuel Tank Plate Complete

Raised cap section preventing dirt from collecting around the cap base. The round cap surface keeps the cap clean. Cap threads on with an o-ring seal. A #8 High Flow Roll Over Vent is included. The top plate can be used on nearly any tank and also bolts right on standard bladders.

- #JOE 13275 \$174.99



Titanium Tail Tank Bolts

The perfect length for mounting the tail tank to any late model car.
#AST 4507KIT \$19.99

LRB Adjustable Tank Mounts

NEW!

Finally a way to mount a tail tank on a sprint car without an 8' piece of lumber and 3 of your x-best friends once you are done!

These mounts replace the fixed tank mounts on the chassis and swivel to fix the ever changing nutsert location on the tail tank.
#LRB FTUM-BLK \$89.95



Klotz Uplon Fuel Lube

Designed and tested at the most extreme temperatures. Red in color so it's easy to see any leaks. This will hold up to anything!
#KLO KL-107 \$10.99



Fuel Tank Cover

Protect your fuel from the hot sun. Warm methanol does not ignite as quick, and may cost you valuable horsepower. Easy to use and store.

- #CRV 906 \$69.99



Royal Purple Max Gear Oil

Max-Gear is an ultra-tough automotive gear oil. Max-Gear outperforms other gear oils because it combines the highest quality synthetic oils with Royal Purple's proprietary Synslide additive technology.

#ROY 1303 \$16.99

NEW!

WE RECOMMEND...

Red Line Shock Proof Gear Oil



Joe Gibbs Racing Oil

XP6 Full Synthetic Racing Oil. Viscosity Grade: 15W-50. Designed for aluminum blocks and looser clearances commonly found in Sprint Car engines. Dyno tests have proven this oil to be worth 7-10 Hp over the yellow jug. Don't let the price scare you away as many Outlaw teams run this oil 3-4 nights between changes.

#JGP XP6 \$15.99



NEW!



Wilwood 570 Brake Fluid

Wilwood's standard brake fluid. Built for cooler temperature braking applications. An economical fluid that will mix with anything.

#WIL 290-0632 \$5.99

Pennzoil 25/50 Race Oil



Hard to find blend used by all off the top engine builders. Sold separately or by the case.

#PEN 3623
\$4.99 Qt. /
\$54.99 Case

At high temperatures and extreme pressures of racing. Heavy ShockProof Gear Oil has a film thickness greater than an SAE 250 lube, but with a drag comparable & light weight lubricant. Resist throw-off, reducing gear noise and preventing tooth breakage.

#RDL 58204 \$12.50

Super Hi-Temp Dot 5.1 Brake Fluid

This fluid will withstand even the toughest drivers on brakes. There simply is no better fluid. Non-silicone based so will mix with anything.

#APF 15601500 \$17.99



Energy Release Grease

G-200 Synthetic Formula is a premium, high temperature grease. Provides excellent performance in severe/hot applications such as disc brake wheel bearings, Spicer and Rockwell U-joints, backhoe hinge pins, fan hubs and fifth wheels, mining and construction equipment.

Formulated with ER, G-200 offers high film strength, resistance to oxidation, rust and corrosion. O-1200 RPM.

#ENR P006 \$7.99



Red Devil Brake Fluid

Used exclusively by Red Devil for longer lasting calipers.

#RED 1032
\$35.00



Scrubs Hand Towels

Make no mistake, these towels are awesome! Designed for painters, They will remove everything from paint to oil. You'll be shocked!

#DYM SCRUBS
\$16.99



Exp 600 Plus

Exp 600 Plus is a highly refined blend developed for extreme performance under the high heat and extreme pressure of professional motorsports.

#WIL 290-6209 \$19.99



Klotz Uplon Fuel Lube

Designed and tested at the most extreme temperatures. Red in color so it's easy to see any leaks. This will hold up to anything!

#KLO KL-107 \$10.99

Energy Release

Used by all of the top teams in motors, steering gears & rear ends. Doubles the life of metals by providing a barrier of oil between them when they touch.

Pint: #ENR P002
\$16.99

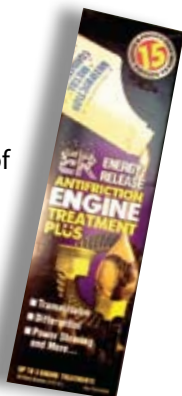
**KSE Power Steering Fluid**

The industry standard for power steering fluid.

#KSE KSM1086C \$10.99

**Mudd Off Concentrate**

Great for applying before the races or packing to make your crew's job easier.

#MUD P601 \$8.50

**Brake Clean**

Removes debris, oil, and grease from anything it touches.

Compare our price!
#SMI BRKCLEAN \$2.99

Royal Purple Ice

Purple Ice is a high performance, synthetic, radiator coolant additive. It reduces engine heat by reducing the surface tension of the radiator fluids for improved heat transfer. Purple Ice fosters optimum coolant flow by helping to prevent formation of scale deposits in the radiator. It also lubricates the water pump seals.

#ROY 1600 \$14.99

**NEW!****K&N Air Filter Cleaner**

Specially blended to remove oil deposits & dirt from your air cleaner.

#KNE 99-0621
\$11.95

Klotz Foam Filter Oil

K&N Filter Oil will not work on Kinser foam filters! This easy to use spray works great for protecting your motor from harmful dirt particles.

#KLO KL-606
\$7.99

**NEW!****Mudd-Blocker**

Not found in stores anywhere, and simply the best mud remover on the planet! Will not affect paint or vinyl in any way and works better than anything else... TRY IT!

#SMI MB \$21.99 (gallon jug)

**Water Wetter Super Coolant**

Tired of overheating? Dyno tests prove-one bottle will drop motor temp 25 deg immediately. Also prevents premature corrosion.

#RDL WW \$10.95

**K&N Air Filter Oil**

A must have on KN Filters, no matter what style. Without it, smaller particles will sneak through the screens into your engine.

#KNE 99-0516 \$7.95

**NEW!****S-D 20 All Purpose Degreaser**

Simply the BEST CLEANER/DEGREASER available!!! This product is used by 100% of the Winston Cup racing field and many of the NASCAR racing field to clean tire rubber, oil and grease from their cars!

#SMI SD-20 \$6.95

**MUD X**

The best mud treatment made. Concentrated gallon allows you to mix at your specs.

#BIO MUDX \$21.99 Gal

SET-UP TOOLS

NEW!



King Adjustable Set Up Blocks

Magnetic on the bottom so they will not fall down. Each set comes with 4 platforms for more adjustment.

Short set from 1 3/4" to 4"

Tall set from 3" to 6" Tall

#KRP 2585 \$61.99

#KRP 2590 \$74.99

JOES Racing Stop Watch

80 lap memory. EZ to read oversize split times on the top line. Rubberized coated ergonomic shape that fits nicely in your hand. One touch recall button right on the face of the watch.

#JOE 28340 \$39.99



NEW!

SpeedMart Rear Axle Birdcage Level

The most important tool in your collection! Top pin centers into predrilled bolt in your birdcage (we can supply you one no matter what kind of cage you have), and precision level on top rotates as you square your rear end. There is no substitute for these guys. Every team must have one.

#KMI BCLEVEL \$69.95

SpeedMart
gettin' it done fast



Digital Level

Make leveling your car quick and easy with this digital level.

#LON 78310 \$99.99

NEW!



EZ Weigh Scale System

Used for dirt and asphalt sprints for setup accuracy. Know for sure your car is set up with the same crossweights as that night you won!

#LON 72595 \$1119.99



AVAILABLE FOR MIDGETS TOO!

Adjustable Set Up Blocks

These handy blocks adjust from 2-7". They make adjusting ride height so much easier. Not to mention the space they save!

#SAL SUB-S \$99.99 set

#SAL SUB-M \$99.99 set



Accutech Memory Stopwatch

Crips one-button action with 10 lap memory. Don't be fooled by competitors gimmicks. You'll know how fast they're going!

Used by Steve Kinser.

#LON 22162 \$28.95



ASSEMBLY & REPAIR TOOLS

NEW!

Air Rivet Gun

Heavy duty, for use with steel or aluminum rivets from 3/32" to 3/16". Great for wings!!!

#ALL 18207 **\$65.99**



SpeedMart Birdcage Tool

Designed by a race car owner who damaged his birdcages trying to get his birdcage bearings in. With this tool you will be able to drive the bearings in and out straight, preventing them from bending the cages or forcing them out of round.

#KMI BCT **\$52.99**

SpeedMart
get 'em 'til done fast



NEW!

Lightweight Aluminum Jack

NEW!

Lightweight 3000 lb. capacity floor jack has a low profile to roll under the chassis. Made of high quality aluminum, jack incorporates a patented hydraulic system to reach maximum height of 17 1/2". Rolls really easy.

#ALL 10425 **\$479.99**



Bolt Extractor Kit

A must have. Ever broke off a header stud or a bolt in the steering arm? Just drill a hole big enough to screw one of these in and pull them out in a snap! A cheap tool but invaluable if you need them!

#ALL 11050
\$46.99



NEW!

Torque Tube & Drive Shaft Checker

The must have tool of the year! Simply lay your torque tube or driveshaft on this checker and make sure it's straight before reassembling a crashed race car.

Made with precision ground bearings and a sturdy aluminum base. Very accurate, and inexpensive, too! Eliminate all questions before going onto the track!

#KRP 2560 **\$62.99**



Safety Wire Twister Pliers

Never lose another race because of loose bolts. Rugged pliers have an end bearing for smoother, faster twisting, especially in tight areas where a second pull is needed.

#ALL 10120 **\$39.99**



Handy Unibit Kit

You will never have to look for a drill bit again! Just drill any size pilot hole and chase it to whatever size you need! A requirement for any racer's tool box. 3 sizes in each kit for your convenience.

#ALL 11040 **\$17.99**



NEW!

EZ Pull Rivet Gun

Will even pull 3/16 steel rivets with ease. Designed to hold up to the abuse of a race team.

#ALL 18206 **\$31.99**



Safety Wire

1 Lb. roll contains 362' of .032 stainless steel wire.

#LON 22599 **\$16.99**

#ALL 10121 **\$16.99**



DMI Front Hub Wrench

Removes dust cap easily without scratches.

#DMI SRC-1998 **\$17.99**

NEW!

King Torsion Bar Reamer

The best torsion bar reamer on the market. Complete with all tools needed to align your torsion bar bushings perfectly. 3/4" hex socket built right in for your impact gun. A little WD-40, a 3/4" socket, 8 bushings, and you are in business!

#KRP 2500 **\$178.99**



AVAILABLE FOR
MINI SPRINTS TOO!

3/8" Cordless Impact Wrench

JOES 3/8 Drive 24V Cordless Impact Guns are great for working on your car. The 3/8 drive lets you use more sockets from your tool box and is perfect for sprints, mini sprints and more. Gun has JOES rubber coating for great grip and feel and comes complete with 2 JOES Prolong TM batteries and charger. 380 lbs torque.

#JOE 32830 **\$249.99**



ASSEMBLY & REPAIR TOOLS

All new shaft holder cutout!



Shock Working Vise

JOES makes this handy vise for working on any take apart shock. Hold the body on one side, and the shaft on the other.

#JOE 19200 19250 **\$219.99**



JOES QA1 Drip Cup

Tired of the mess of working on shocks? Before beginning your shock work, simply install this drip cup over the body of the shock and you are in business! No more oil dripping off of your table.

#JOE 19300 **\$49.99**

Rear End Snout Heli-Coil Repair Kit

Simple jig allows you to drill and tap the face of the rear end square. Without it, it's tough to get the bolts in square.

#LRB T0002P
\$134.95



Brake Flaring Tool

Brake lines must be flared correctly. Cheap auto parts tools do not have the right degree for aluminum AN fittings. This has everything you need to flare your brake lines perfectly.

#ALL 11015 **\$28.99**

LRB Snout Facing Tool

This precision tool allows you to face the snout on Your Rear End. Features a carbide cutting tool and a .005 mark on knob. Comes with "Bolt-t-mount" lower shaft. Great finishes. Internal coupler. Can also mount dial indicator in place of cutter to measure surface. Made from 6061 aluminum.

#LRB T0001P **\$149.95**



JOES QA1 Shock Wrench

Spanner wrench on one end and jam nut wrench on the other side. 1 wrench will completely disassemble a QA1 shock.

Small body #JOE 19085
Large body #JOE 19080
\$48.99



Deluxe Brake Line Cutter

More precision than the smaller ones and includes a reamer built right in.

#ALL 11011 **\$12.99**



Dial Caliper

Quality hardened stainless steel dial caliper is shockproof and capable of measuring items from .001" to 6" in increments of .001". Includes protective carrying case.

#ALL 96410 **\$34.99**

QA1 Shock Wrench

This combo wrench fits both large and small body QA1 shocks.

#QA1 7791-104 **\$19.95**



Coil Over Adjuster Wrenches

We've got one with a short and long handle for more leverage.

Std. #JOE 33000 \$38.99
Long #JOE 33500 \$39.99



Aluminum AN Wrench Set

The best way to make your aluminum fittings last. Keeps crew from over tightening, too.

#ALL 11100 **\$69.99**

5/8" Radius Rod Taps

Tired of fighting gummed up threads? We stock the hard to find left and right hand threaded taps for the threads in the radius rods and threaded spuds on sprint cars.

RH #ALL 11066
LH #ALL 11067
\$14.99



TOOLS

ENGINE TOOLS

Feeler Gauge Handles

Full-Bore Race Products has come up with an inexpensive set of feeler gauge handles to compliment our E-Z Wrench Valve Adjuster Tool. Each set comes with 2 handles, one marked "EX" (exhaust) and the other "IN" (intake). Put your own feeler gauge blades in the handles



according to your cam manufacturers specifications and they will always be ready when you are.

#FBR 234-A
\$18.99

Mallory Static Timer

The best way to set your mag timing before firing the car. Box will buzz until the timing of the magneto is perfect. Simply loosen the mag-to-base clamp and spin the generator until the box stops buzzing. A must have for setting timing.

#MAL 28355 \$174.99



Rapid Engine Rotator Tool

The most desired tool on the market and up until now the hardest one to get. This handy wrench allows one person to adjust the valves on a sprint car. Splined insert ratchets allowing motor tuner to stand on one side of car and run all of the valves at once. Any engine man's best friend!

#SNO RTR \$285.99



MOROSO



4 Seasons Block Heater

No external boxes or hoses. These bolt to the side of the block and heat the engine from the bottom up.

#FSR 120832 \$349.99



Oil Preheater

Will heat 8 quarts of oil to 100° in approx. 20 minutes. Weldable bung for oil tank placement with STD 110 volt power cord. Engines will live much longer on consistent temperature oil.

#MOR 23980 \$77.99



Flaming River Timing Light

The easiest timing light in the world for sprint car mechanics. These things are tough and will take the abuse of a dirt race team!

#FRI 1001LIGHT \$59.99

NEW!



Liquid Filled Leak Down Tester

The only leak down tester sold with a liquid filled gauge. Ever notice when you leak your motor down, the needle is shaking or hard to locate. Liquid filled gauges are the only way to prevent that. Sold complete with 2-18" x 3/8" hoses. One with a #6 female for barrel valve and one with a 14mm o-ringed spark plug adapter for leaking down the cylinders.

#KRP 1910 \$151.99

Mini-Temp Series Laser Temp Gun

These make tuning your motor so easy. Great for checking exhaust temps and setting side to side.

#LON 50612 \$84.95



longacre
RACING PRODUCTS

ENGINE TOOLS

TOOLS

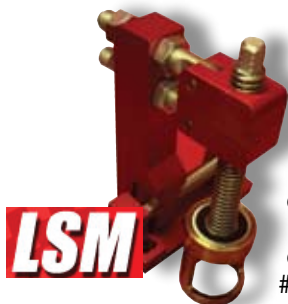

Valve Spring Changer
 LSM developed the standard for changing valve springs with their innovative design. The LSM Spring Removal Tools are simply the best quality, and easiest to use. It makes changing valve springs a fast and simple one-man job.
 #LSM SC-100 \$223.99

LSM One-Tool Valve Adjuster Tool
 One wrench to adjust the valves. It's like having 16 valve lash adjusting tools in one. One-Tool configures to adjust ALL shaft and stud mount rocker systems on the market today.



NEW!

Just snap on the appropriate standard 1/2" drive socket, insert the correct hex key and you are good to go.
 #LSM 1T-100 \$199.99
 Additional Hex Keys
 1/8" #LSM 1T-1/8 \$4.99
 3/16" #LSM 1T-3/16 \$4.99
 5/32" #LSM 1T-32 \$4.99



Oil Filter Cutter
 Cut your old filter open to spot problems before they cost you an engine. Simple easy to use!
 #LON 77750 \$52.95



Deluxe Spark Plug Reader
 10x Magnification for accurate readings.
 #LON 50886 \$39.95



Proform Valve Spring Checker
 Adjustable on-head valve spring pressure tester for various shaft style and stud mount roller rocker systems. It features a 0-600 lb liquid filled gauge and is available in standard or low profile configurations. Comes with adjustment shim kit which enables adjustment to within .050 of rocker arm pivot length. Includes set-up and adjustment guide. (Low profile unit handle length is 2.4" shorter than standard)
 #PFM 67597 \$237.99



Economy Valve Spring Checker
 The ideal tool for checking valve seat pressure on an assembled engine.
 #MOR 62391 \$101.99



Oil Tank Heater
 A simple way to preheat your oil with no welding or fitting.
 #MOR 23995 \$71.99



Valve Lash Tool
 This awesome tool gives you an extra hand when adjusting your valves. No toolbox is complete without one. Specify sizes for wrench and Allen when ordering.
 #ALL 96400 \$34.99



Exhaust Port Block Off Plates
 Great for engine storage.
 #HRP 0916 \$20.99 set

TIRE TOOLS



Stagger Tape

Long enough for big right rear tires.
Magnetic, too!
#ALL 10111 \$6.00



IDEAL Tire Groover

A grooving tool that quickly & easily grooves dirt tires.
Complete with 12 adjustable #4 blades & brass #4 grooving head.
#IDE 125-250W \$84.99



NEW!

Hot Lap Tire Softener

Works on asphalt or dirt for maximum tire grip that lasts the entire race. Tires run 18-22° cooler and last up to 50% longer. Hot Lap is proven not to "give up" after several laps, extends tire life and is undetectable. One gallon can.
#PRB 6000TS \$76.99

Heavy Duty Tire Siper

Uses 6 standard utility blades for up to 6 sipes per block. Slides much easier than the small ones we used to use. Strong aluminum construction.
#KRP 2580 \$79.99



NEW!

New Heated Tire Siper

This 13 Blade Siper will Sipe tires quickly and effortlessly while maintaining effortless precise control. Tire Siping can greatly improve traction and decrease tire blistering. Tool heats in 10-15 minutes. 110V plug in operation only.
#ALL 10266 \$219.99

NEW!



Tire Marking Stick

Writes reliably on any surface, even super cold nights. Use to write your stagger measurements on each tire for easy calculation.
#LON 50880 \$3.95



Lightweight Aluminum Air Tank

Quicker than dragging the air hose around the car! This will make all other crew guys jealous! Special inlet valve fills in less than 10 seconds.
#LON 50459 \$136.95

NEW!



Allstar Tire Groover

Add extra traction in a matter of minutes! Tapered, razor sharp blades groove faster and easier with less heat. 4 different heat settings to choose from. Comes complete with flat blades in 4/32", 6/32", 8/32" and 10/32".
#ALL 10270 \$369.99



IDEAL Heated Knives

Replacement Tire Groover Blades

We stock blades for both groovers up to 1/2" cuts
#IDE 2-6 \$8.99
#IDE 8-10-12 \$9.99

TIRE TOOLS



Sprint Bead Breaker
A must for breaking down tires.

Available in wide or narrow flange.
Std: #ALL 10105 **\$48.99**
Wide: #ALL 10106 **\$49.99**



Aluminum Wide Jaw Bead Breaker

This easy to use bead breaker is a must have, especially with shiny new wheels. Won't carve into edges like many steel ones do.
#MNW ABB **\$159.95**



Deluxe Tire Pressure Gauge

Our favorite!
-2 1/2" Glow in the Dark face for high accuracy and easy readability
-High flow release button and swivel chuck
-HOLDS PRESSURE UNTIL RELEASED
-Internal gauge damper for more accurate readings and longer life
-Ultra flexible 17" hose
0-15 by 1/4 lb #LON 50452 **\$44.95**
0-30 by 1/2 lb #LON 50422 **\$44.95**

Valve Core Tool

Conveniently stores extra valve cores in the handle.
#LON 50270 **\$16.95**



Aluminum Bleeder Check Tank

Compact tank allows you to accurately set regular and diaphragm axle bleeders perfectly every time. Built in tray for storage, too.
#FSR 122853 **\$119.99**

Replacement Glass for Longacre Tire Gauges

Now you can fix them when they get dropped and broken.
#LON 50498 **\$3.95**



Saldana Wheel Wrench

The best wheel wrench on the market!
Comes with adaptors for all three weights of axles.
#SAL WW-S **\$161.99**
#SAL WW-M **\$139.99**
#SAL WW-MS **\$131.99**



Magnum Tire Gauge

Huge 3 1/2" Glow in the dark face for high accuracy and the easiest readability. High flow release button and swivel chuck. Holds pressure until released. Internal gauge damper for more consistent accurate reading. Comes complete with silver case for protection.
LON 0-15 #50454 **\$79.95**
LON 0-30 #50424 **\$79.95**



EZ Tire Roll Stand

Now you can check stagger, sipe, groove, inspect and clean tires without chasing them all over pits. You can adjust the width for different tire sizes and break it down for easy storage.
#JOE 32200 **\$69.99**



Tire Durometer

Tire hardness has a huge affect on your car's performance. A tire too hard won't bite and a tire too soft may wear quickly or even ball up. Also tire hardness changes during its life cycle. To run your best you must keep track of all your tire's hardnesses. This easy-to-use tool will help you do just that-quickly, accurately, and easily.
#LON 50540 **\$69.00**



PIT TOOLS



Fuel Tank Cover

Protect your fuel from the hot sun. Warm methanol does not ignite as quick, and may cost you valuable horsepower. Easy to use and store.

#CRV 906 \$69.99



Outlaw Hood Blanket

Running your engine cold can damage it worse than anything else. This Thermal Hood Blanket will help keep your engine up to racing temperature for a fraction of the cost

NEW!

of a Hot Setup. Side flap snaps up so your headers don't burn it, too!

#KRP 2610 \$199.99

XXX Pit Stands

Pit Stand. Anodized aluminum. Comes with rubber inserts to stop car frames from sliding in the pits. Wide feet so cars won't sink into dirt. Stackable, lightweight and compact. Sturdy and strong to get your Race Car in an ideal position to work on. Sturdy fabrication won't buckle under high load capacity like our competitors.

#TRX PA-0009 \$159.00 (pair)



NEW!

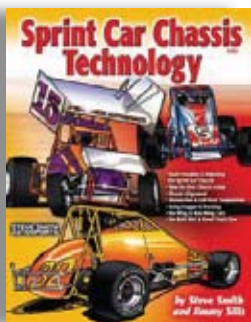

Steve Smith Sprint Car Tech Book

Great advice on setting up and sprint car as well as driving one. Jimmy Sills aids in describing what a driver feels and how to relate that into a set up change. Skills such as setting and adjusting ackerman, roll center, squaring car, and using stagger are described inside.

#SSA S282 \$28.95

Steve Smith Mini Sprint Tech Book

Learn micro and mini sprint technology start to finish. Great advice on chains, roll center, pivot points, where to put weight, etc..

#SSA S286 \$28.95



HRP EZ Store Motor Stands

Simply the best motor stands made. Tubular structure so they slide easy. Stores in 18" x 8" x 1" when not in use. No sharp edges to scratch trailer floor.

#HRP 6002 \$69.99



Sprint Car Hood Shade

Keep your motor and electronics cool in the hot sun with this hood blanket made to fit nicely around your hood.

#CRV 783 \$169.99



Chrome Plated Chassis Stands

Frame Stand and Dolly. Plated. Sturdy and strong to get your Race Car in an ideal position to work on. Heavy duty casters make moving your race car around the shop easy. Removable 1" block on left side so stand fits both raised rail and standard rail chassis. Light weight and super strong. They collapse to lay flat for easy storage in a hauler.



Sold as a pair.
#TRX PA-0002 \$219.99



Engine Pulling Strap

Simply the easiest way to change a motor. Top teams have one attached to the spare motor in the trailer, too!

#CRO 11645 \$19.99



Engine Box

Used by all major engine builders to store and ship engines.

#SCR 5108 \$214.99

scribner plastics

PIT TOOLS

Rolling Car Stands
The nicest rolling stands on the market. Fully adjustable in height, and equipped with a brake for convenience.
#SHR STANDS \$269.95



NEW!



King Wash Plugs with Spark Plug and Nozzle Keepers

All aluminum anodized o-ringed plugs for the injector of your car to keep water out when washing. When car is put away leave them installed for a place to put each spark plug and nozzle when doing motor maintenance. Built for all sizes of injectors, specify size when ordering.
#KRP 1935 up to 3" \$128.99 to \$135.99



scribnerplastics

5 Gallon Jug
Available colors in stock: clear, red, blue.
#JAZ 10-015-xx \$26.99

Scribner D-Shaped Fuel Funnel

Used by all the top teams and legal at all racetracks.
#SCR 6110X \$15.99



scribnerplastics

D-shaped Scribner Fuel Funnel Filter

SpeedMart filters its fuel twice before ever distributing it, does your local provider? Very cheap insurance for your expensive motor! Fits D-shaped fuel funnel.
#SCR 6119 \$5.95

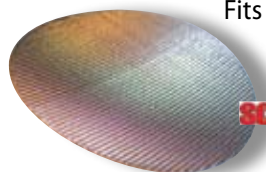

scribnerplastics



72 Piece Cap & Plug Kit

Makes a great addition to your tool cart. Eliminates the mess of tape. Sized from -3 to -12. Super cheap!
#FAS CPP72 \$18.00

NEW!

Mudd-Blocker

Not found in stores anywhere, and simply the best mud remover on the planet! Will not affect paint or vinyl in any way and works better than anything else... TRY IT!
#SMI MB \$21.99 (gallon jug)



New Generation Mud Scraper

Do not leave home without one of these. Make cleaning your racecar 10 times easier. Will not break, & stores nicely in the tool cart. Your crew guys will thank you.
#ALL 44165 \$24.99



High Quality Mud Scrapers

Inexpensive, yet necessary for any dirt race team.
#POP 1500x \$6.95

PIT TOOLS

Alpinestar Crew Gloves with Magnet

Lightweight and flexible mechanic's glove. Synthetic suede leather palm construction.

Lightweight and breathable ribbed spandex top.

Enclosed magnet to hold small screws and bolts. Velcro® wrist strap closure.

Plastic print detail on top of finger. Velcro® wrist closure. #ALP 355258 **\$29.99**



NEW!



King Rear Arm and Radius Rod Builder

Here is one of the most handy tools that you can ever own. This tool will save you time in the shop and at the track. This Precision Manufactured Gauge lets you build and duplicate all of your Radius Rods and the Rear Arms on your car. Simply build and square your car perfect, tighten everything, and take the radius rods and rear arms off of the car and put them in this tool, set the tool and copy everything. No resquaring in a crash! #KRP 2530 **\$181.99**



Pit Apron

Tired of ruining clothes on work nights? This is the best way. Hang it up at the shop when the night is over for the next week! #SIM 39035 **\$22.95**



Multi-Colored Race Tape

Many colors available! #ALL 141XX **\$6.99**

Sure Shot Mudd Off Sprayer

No pit stall is complete without one! Uses less Mudd Off than other sprayers since it sprays a wider path. #SUR A2000 **\$59.95**



Paulson Bubble Goggle

These are the cat's meow. Controls 99% of dust. A great gift for crew guys or fans! Clear: #PAU 100 **\$11.95**
Amber: #PAU 300 **\$11.95**



Tie Wraps

Available in grey, black, natural, red, blue yellow & purple. Packaged 100 per bag.



#ALL 141XX
7 1/4" **\$5.99**
11 1/4" **\$11.99**
14 1/4" **\$14.99**



Pit Mat

Never lay in the dirt again with these inexpensive EZ store pit mats. Remember image is everything to potential sponsors! #ALL 1012X **\$24.99**



Foam Roll Bar Padding

Many colors to choose from, and very reasonably priced. #LON 657x (specify color) **\$4.95**

Hi Density Roll Bar Padding

High density roll bar padding that doesn't look bulky and won't drip or molt in a fire. Red or Black.

Black: #LON 65182 **\$12.95**
Red: #LON 65184 **\$12.95**





Gear Case Rack
Built from .080 aluminum. Holds 10 sets of gears in cases.
#HRP 6518 **\$33.99**

Wall Mount Radius Rod Rack
Holds 16 Radius Rods without a single pin or clip. O-ring pins allow user to slide rods on and off quickly. Lower tray comes off easily and is held on by lip on outside. Mounting holes pre-drilled.
#HRP 6521-D-20 **\$157.99**



Wall Mount Lubricant Tray
Available in medium and tall version. Tall version will hold every type of lube and cleaner needed for a sprint car in one rack!
Medium #HRP 6471 \$79.99
Tall #HRP 6473 \$133.99

Wall Mount Paper Towel Dispenser
Eliminates messes.
#HRP 6430P **\$34.99**

HRP Air Line Storage Rack

Holds 50' of airline without a clip or a strap. Lip on face catches edge of airline to keep it from falling off in the trailer.
#HRP 6280 **\$39.99**



Fluids Storage Rack
All sizes below we stock in powder coated and non powder coated versions. 3 1/4" wide holds aerosol cans. 4 1/2" wide holds oil quarts and mud off jugs.



Aluminum Gear Change Tray
Room for rear end oil, nuts and gears. Oil pours out easily too.
#HRP 6220 **\$40.99**



16" w x 6qt x 3 1/4" d Aerosol Bin
#HRP 6300P **\$35.99**



16" w x 6qt x 4 1/2" d Oil Can Bin
#HRP 6301P **\$35.99**

32" w x 12qt x 3 1/4" d Aerosol Bin
#HRP 6305P **\$39.99**

32" w x 12qt x 4 1/2" d Oil Can Bin
#HRP 6306P **\$46.99**



Drivers Helmet Preparation Cabinet
"Driver's best friend!" Folds away when not being used.
#HRP 6410P **\$198.99**



Spacer Storage Tray
Available in drawer or wall mount.
Wall Mount #HRP 6181 \$35.95
Drawer Mount #HRP 6180 \$21.00
Wall mount version also available powder coated white
#HRP 6181P **\$41.99**



Sprint Car Axle Racks

Made from 3/16" aluminum and welded together. 5 choices of designs: Rear End only, Front End only, 1 Front 1 Rear, 2 Front 1 Rear, Front Axle Pack (2 Blank Axles)
 #HRP 6775: **Axle Rack (1 frt .1 rear) \$179.99**
 #HRP 6776: **Rear End Rack (2 frt. 1 rear) \$209.99**
 #HRP 6777: **1 Front Axle \$130.99**
 #HRP 6778: **2 Blank frt. \$101.99**

No Bolts or Pins!



Steering Gear Rack

Use on mule or trailer for steering gear storage.
Standard Gear
 #HRP 6780-1 **\$84.99**
Gen 2 Gear
 #HRP 6780-3 **\$84.99**



Wall Shock Mounts

Holds 8 shocks wide and 2 deep each pinned separately.
 #HRP 6522-15c **\$169.99**

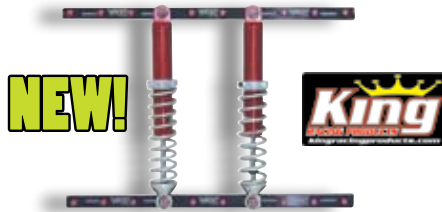

King Shock Hanger Mounts

O Ring Shock Racks with slotted mounting holes that will bolt to anything. Holds 10 Shocks. Will even hold shocks with coil springs attached.
 #KRP 2630 **\$119.99**



Wall Mount Nose Wing Rack

Padded on the nose wing contour. Nose wing mounts quickly and very clean! Comes with straps.
 #HRP 6553 **\$69.99**

Tail Tank Mount for Trailer Wall

Mounts an outlaw tank in 4 spots for easy storage.
 #HRP 6781 **\$74.99**



Wall Mount Header Racks

Simply the best available. 3 nuts and you're in business. Keeps headers flush to the wall.
 #HRP 6700A **\$59.99 set**

Torsion Bar Rack

Holds 10 bars. Easy to use, easy to read the numbers on bars.
 #HRP 6350P **\$134.99**



Trailer Radiator Mount

Wall mount easy to use, and NO PINS! Two knobs on each side drop the sliding tabs down to tightly secure the radiator in the rack.
 #HRP 6340 **\$89.99**



Top Wing Trailer Mount

Very simple and compact. Adjustable from the ceiling. Wings can hang with the big sideboard in the center (extender needed) or on the wall.
Wall and Roof Mount #HRP 65506551 \$209.99





HRP Collapsible Tire Rack
The best tire rack ever built for resale. Available in 4', 6', or 8' lengths. Powder coated black and easy to install. Complete when you get them, just hang them up. Will fit dirt or asphalt sprint car tires.
#HRP 6600-48 \$345.99
#HRP 6600-64 \$415.99
#HRP 6600-96 \$625.99



Ratchet Strap Rack
Holds two ratchet straps tight against the wall for easy storage.
#HRP 6006P \$34.99



Broom Racks
Finally a place to hang the broom that is sitting in the corner!
Small #HRP 6393 \$8.99
Large #HRP 6392 \$9.99



Grease Gun Rack
#HRP 6298 \$16.99

Flashlight Holder

Mount one just inside the trailer door so you can reach it to hit the guy who left the 12 volt light on all night with the flashlight.
#HRP 6299P \$29.99



Shovel Rack
#HRP 6391 \$8.99



Electrical Cord Storage Rack
Keeps cords clean!
#HRP 6275P \$32.99



Nose Wing Tool Tray
Holds tools in one spot while maintaining motor or car. Works awesome!
#HRP 6009 \$75.99



Duct Tape Holder
#HRP 6390P \$20.99

Fuel Funnel Storage Rack

#HRP 6261 \$42.00
Powder Coated:
#HRP 6261P \$49.99

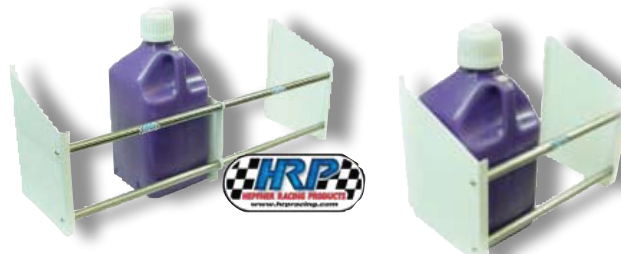

Wall Mount Fuel Jug Racks

Available in 2,4,6 jug capacity. Mounts easily to wall and each 2 jugs are separated for strength. Easy to keep clean unlike the others that have a bottom. Just lift the jugs and sweep underneath!
2 Jug: #HRP 6360 \$125.99
4 Jug: #HRP 6361 \$140.99
6 Jug: #HRP 6362 \$160.99



Air Gauge Holder

2 sizes available. Small one holds 2" gauge, large holds 2 1/2" gauge.
Small #HRP 6380 \$14.99
Large #HRP 6383P \$22.99

SpeedMart Hoodie Sweatshirt

s-xl \$29.99 xx \$32.99



NEW!



FRONT



BACK

SpeedMart Racing Team Cap

\$19.99

Fitted Hats: Sizes S/M and L/XL available

NEW!



SpeedMart 2010 Calendar

\$16.99

Blacktop Lifestyle Shoe

New from Simpson. A great crew or everyday life shoe. Very comfortable! A wide forefoot section to fit every foot! Sold in sizes 8-14 including 1/2 sizes.

#SIM BT \$59.95 (specify size)



NEW!



Simpson Racing Team Cap

#SIM 60799x \$19.99

Fitted Hats: Sizes S/M and L/XL available



Simpson Beanies

#SIM 42023x \$19.99 (specify color)

Fitted Hats: Sizes S/M and L/XL available



Crew Shoe

Oil resistant, all condition high profile sole with aggressive lug-grip pattern. Super lightweight athletic insole for full support.

Sizes: 4-14

#SIM 560xx \$49.95 (specify size)



NEW!

Oakley Crew Shoe

High Quality split suede with shielded lacing. High abrasion toe and heel cap. Internal compression molded EVA midsole. Available in sizes 7-13.

#OAK 11089xx \$99.99 (specify size)



Chicane Lifestyle Shoe

A comfortable "racing shoe" like feel, without the expense. Great for wearing anywhere! Non-slip sole with satin suede and leather top for durability.

Sizes: 4-14

#SIM 590xx \$59.95 (specify size)



Impression Lifestyle Shoe

Look like the champion you are, even off the track. Low cut vintage racing style with Simpson "S" logo embossed on sides. Extra set of laces included.

Sizes: 4-14

#SIM 580xx \$59.95 (specify size)



Master Cylinder Kit

The universal master cylinder used in dirt and asphalt sprinters. Use 7/8" if you want to push pedal harder to stop (eliminating excess brake rotor warping). Use 1" if you want instant force on rotors for quicker stopping. Also use 1" when running a right rear brake.
 3/4": #WIL 260-3374 **\$68.99**
 7/8": #WIL 260-3376 **\$68.99**
 1": #WIL 260-3378 **\$68.99**

King Master Cylinder Spring

Prevent unintentional brake riding. Driver will often rest his foot on brake without even knowing it! Very heavy duty spring that installs on master cylinder and resists gentle force on brakes. Works awesome!!!
 #KRP 2400 **\$15.99**



NEW!



Master Cylinder Heim

Don't forget to order one with your master cylinder!
 #QA1 AFR5 **\$9.50**



2 lb. Residual Pressure Valve

This valve keeps 2 lbs. of pressure on your calipers. Helps eliminate excessive pedal travel.
 #WIL 260-1874 **\$21.99**

J & J Residual Valve

Built correctly for sprint cars with a male 1/8" NPT male fitting on one end that threads directly into the master cylinder. The other end accepts the 1/8" NPT brake T for simple lightweight plumbing.
 #JNJ 109015K **\$24.99**



NEW!



Master Cylinder Fitting

Screws into the back of the master cylinder to eliminate unnecessary fittings. 1/8" NPT on one side, -3 flare on other sides.
 #XRP 982603 **\$12.99**

Wilwood Master Cylinder Rebuild Kit

If your brakes become spongy, it's one of two things; a bent rotor or a bad master cylinder. Fix one problem cheap!
 #WIL 260-38XX **\$20.99**



Featherlite Brake Setup

The ultimate sprint car brake. Utilizes a 10.4" ceramic coated vented .810" titanium or steel rotor with our lightweight 200 series caliper. The .810" vanned titanium rotor weighs only 2 lbs. 11 oz, and the steel weighs only 4 lbs. 2 oz. Steel is investment cast 8740 chromoly. Redesigned caliper mount for ultimate strength. There is no better, lighter, brake system!

Featherlite Steel Setup #RED FEA-4130 \$1195.00
Titanium Rotor Setup #RED 410-8100

NEW LOW PRICE \$1369.99



Lightweight Inboard Brake Kit

The best value in lightweight steel brake kits. Complete with:
 • 1/2' Brakeman Scalloped Rotor
 • DMI Floating Clamp
 • Rotor Clamp Spacer
 • Wilwood Billet Dynapro Caliper
 • Pads
 • Titanium Inboard Caliper Bolts
 • Titanium Rotor Bolts
 #SMI K-IBLW **\$569.99**



Economy Inboard Brake Kit

Excellent stopping power for a great price! Complete with:
 * DMI Scalloped Inboard Rotor
 * DMI Floating Brake Clamp
 * Wilwood Billet Dynapro Caliper
 * Pads
 #SMI K-IBSTD **\$395.99**



Entire Rear Brake System Only \$395.99



Left Front Caliper Mount

For 10 1/8" Rotor with Allen Bolts. Super strong!
#MNW CB10 **\$14.95**



Left Front Caliper Mount

For 10 7/8" Rotor with Allen Bolts. Won't flex!
#MNW CB11 **\$14.95**



LRB Built Strong Caliper Mount

The only brake mount that will hold up to the punishment of the incredible braking of the Red Devil System. This brake mount will not flex, break, or crack. Held on by 6 bolts. All hardware provided.
#LRB BMRD10 **\$300.00**

NEW!



Billet Dynapro Caliper

Wilwood's lightest sprint caliper. The most widely used caliper on the market. Uses 4" slotted pads. Sold in two versions depending on rotor thickness. It is recommended you purchase the narrowest caliper you can to keep pistons as far in the caliper as possible.

Narrow Caliper (3/8-1/2" rotors)
#WIL 120-9734-SI **\$164.99**
Wide Caliper (.810 rotors)
#WIL 120-9736-SI **\$164.99**

Left Front Steering Arm Bolts

Tapered head countersunk bolts sized perfectly for the left front steering arm of a sprint car. Tighten them down with an allen and go!



#AST 3519KIT **\$28.99 set**

Titanium Left Front Caliper Bolt Set

Sold in sets of 2. Bolts caliper to left front caliper mount without jam nuts to save weight.
#AST 5610KIT **\$18.99**



Wilwood Front or RR Caliper

Used on Sprint car front ends or 600 Minisprints.
#WIL 120-10188 **\$99.99**



Front Caliper Brake Pad Spacers

Spacers to place behind your brake pads in your front caliper to take up the dead space as your brake pads wear down. Aluminum so weight is not a factor.
#KRP 2420 **\$3.50 ea.**



Inboard Caliper Bolt Retainer

Stop the worry of your inboard brake caliper coming loose. This kit comes complete with a Dog Bone that goes on first and also acts like a washer, then you just thread your bolts into the Rear End Side Bell. Once you have them tight into the Side Bell, all you need to do is slide the retainer over the hex of the bolt. Install the safety spring and you're done! Installs in seconds.
#KRP 2236 **\$19.99**

Wilwood Superlight Caliper

This is the newest edition to sprint car brake calipers. Inexpensive and lasts forever. More stopping power because it uses 4 3/4" pads instead of 4". More surface area to resist fluid boiling.



#WIL 120-7430-SI **\$184.99**

Titanium Inboard Brake Caliper Bolts

Sold in sets of 2. Bolts caliper directly to rear end. Very strong!
#AST 4715KIT **\$22.99 set**



Wilwood Dynapro Caliper Front Asphalt

Also used on 1200 mini sprints or midgets. Used on sprint cars where 2 brakes are used. 5.25 Bolt center requires front mount and 4 ear spindles.
#WIL 120-9695 (3/8" rotor)
#WIL 120-9693 (.810" rotor) **\$159.99**





DMI Splined Floating Brake Clamp

Stronger than the competitors magnesium version, and twice as durable. Threaded ears for easy mounting. Uses regular coarse thread bolts. Will hold up to any rotor!

#DMI SRC-2930 **\$113.99**



RR Spline Rotor Adaptor

Use your existing LF rotors on the right rear brake with this lightweight brake mount. Exactly the same thickness a standard right rear rotor, so spacing stays the same.

#DMI SRC-2701 **\$27.99**

Floating Rotor Mount

The first complete universal floating rotor mount for sprint cars. No more warping brake rotors, no more breaking ears off of rotors because they can't float as they get warm. Will adapt to any brake rotor and strong enough to hold up to the thick .810 rotors.

#DMI SRC-2932 **\$219.99**



Red Devil Complete Front Brake System Titanium Rotor

A Sprint Car Brake System is only half way done if only the rear has the Red Devil Featherlite System. Red Devil also builds the lightest, most complete left front also. Allows the driver to hold the throttle down entering the corner and apply the brake, locking the left front up and planting the front end.

#RED 410-7600 **\$745.00**

Titanium Front Rotor Bolts

Beveled perfectly to mount any sprint car front rotor to all front hubs.

#AST 3507KIT **\$33.99**



Front Brake Rotor Bolts

Special taper that is very hard to find. We sell them in 3 packs.

#DMI SRC-1993 **\$9.99**



NEW!

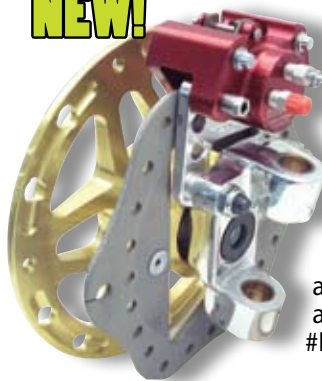

RED DEVIL BRAKES
Ultra Lite
Featherlite System



Red Devil Featherlite Button Kit

A must have when running the Featherlite System. Bolts and floating mounts are unique to Red Devil and you won't find them at any hardware store.

#RED BUT KIT **\$60.00**



Titanium Inboard Brake Rotor Bolt Set

A complete kit for the inboard rotor. Coarse thread to thread directly into rotor clamp, and sized to perfect length.

#AST 4510IB **\$45.99**



Winters Brake Clamp Spacer

Required with all of the new floating clamps. Aligns a Winters rear end and a DMI floating brake clamp up perfectly so the rotor is right in the center of the caliper. Eliminates the centrifugal force from shoving the brake rotor into the caliper on the housing side of the rear end. Keeps the brake pad wear equal.

#WIN 2299 **\$19.99**





Brakeman Revolutionary Steel Front Rotor

Very light steel front rotor! Allows driver to turn the car with the brake on small tracks without losing momentum. You'll never run another left front rotor again!
#BRA 3-1075 \$129.99



Front-3 Lug Rotor
10 1/8" with holes
#DMI SRC-2700 \$42.99
10 7/8" with holes
#DMI SRC-2710 \$42.99

NEW!

King Economy Left Front Steel Rotor

Need more stopping power for your money? The King left front steel rotor is the answer. Available in 10 1/4" and 10 3/4" configurations.
#KRP 2465 \$79.99
#KRP 2470 \$82.99



Wilwood .810 STD Sprint Rotor

Available solid or drilled. This rotor is reasonably priced and without a doubt the most common rotor for racing.
#WIL 160-0277 \$51.99

Brakeman Revolutionary 1/2" Rotor

Truly the best stopping power for the money! Once you switch to these lightweight 1/2" rotors you won't ever change. No fancy brake pads or clamps.
#BRA 3-121950D \$164.99
Sold in our Lightweight Brake Kit Also



Right Rear Splined Rotor

The most reliable aluminum RR brake rotor out there. Use with Wilwood polymatrix Q pads for best results.
10" #WIL 160-3270
11" #WIL 160-3275
\$64.99



Lightened Inboard Brake Rotor

Weighs 5.99 lbs! 3 1/2 lbs lighter than std .810 rotors. Fits standard brake clamps
#DMI SRC-0811 \$69.99
Sold in our Economy Brake Kit

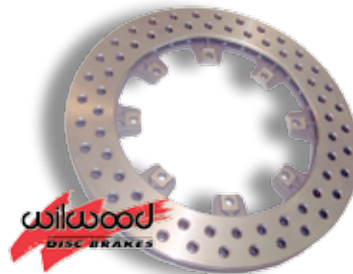

Wilwood Drilled .810 Rotor

Inexpensive, yet lighter than std .810 rotor with equal braking power. Saves a half a pound.
#WIL 160-5865 \$64.99

Rocket Lightweight 4130 Brake Pedal

Built to fit all recent chassis. Including raised rail cars. #ROC BPS \$65.00



Titanium Brake Pedal

This thing is so light! Works in any of the new cars- raised rail or not. Made from 1" tubing for zero deflection. #BCK TI BRK \$109.99



Right Rear Birdcage Caliper Mount

Fits most birdcages. #DMI SRC-2581 \$14.99



Wilwood Caliper Rebuild Kit

#WIL 130-2655 \$8.99



XXX Race Company Sprint Car Brake Pedal

Sprint Car Brake Pedal. Lightweight 4130 Chromoly. Black powder coat. Fits all cars, but designed for raised rail chassis. #TRX SC-CH-0005 \$51.95

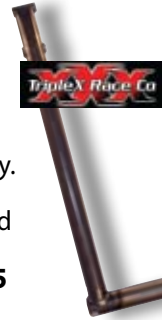

Left Front Caliper Brake Line Rock Guard

Protects fitting from breaking off! #DMI SRC-2820 \$9.99



Replacement Caliper Bleeders

Will fit most all models. #ALL 50180 \$2.99 #ALL 50180-4pk \$9.99



SpeedMart Power Brake Bleeder

1 man bleeder system!!! Finally a system that actually works. Screw the cap onto the master cylinder and hook up the catch cans to each caliper, and brake bleeding is no longer a hassle. Perfect every time! #MOT 0100 \$51.99



Brake Line Quick Disconnect

These make front or rear end changes so easy. The expensive aluminum ones have been used for years. These economical steel units work the same for 1/6 of the cost. #WES QRBRKFT \$34.95



NEW!



Aluminum Brake Line Quick Disconnect

100% Dry Brake Coupling. This dry brake coupling is manufactured to let you disconnect and connect your brake line without getting any air in your brake system. Manufactured from Billet Aluminum and Hard Anodized for protection. #KRP 2435 & 2440 \$386.99

Knob Style Brake Proportioning Valve

Used on most asphalt sprint cars for adjusting the amount of pressure to front calipers. Very easy to turn while racing. #WIL 260-8419 \$48.99



Lever Style Brake Proportioning Valve

Decrease up to 57% line pressure, the most of any available valve. Lever style has six detents. #WIL 260-8420 \$82.99





Kevlar Hi Strength Brake Flex Lines

These are the best looking brake lines out there! Made from bullet proof vest material for durability and colored blue so they even look light. Available in many colors on special order.

- 18" #GDR 318BK \$19.99
- 21" #GDR 321BK \$19.99
- 24" #GDR 324BK \$21.99
- 24" ST/90 #GDR 32490BK \$46.99 (required for Red Devil Inboard Brake)



Brake Flaring Tool

Brake lines must be flared correctly. Cheap auto parts tools do not have the right degree for aluminum AN fittings. This has everything you need to flare your brake lines perfectly. #ALL 11015 \$28.99

Teflon Lined Stainless Steel Braided Brake Lines

We carry flex lines from 5" to 28" with either straight fittings on both ends or a 90 deg fitting on one end. Also available in -4 for oil pressure gauge & wings. #BKL X-XXX \$14.99 w/ 90° fitting on one end: \$19.99



25' Steel Brake Line Coil

Use with -3 aluminum nuts & ferrals. #ALL 48040-3 \$24.99



Red Devil Brake Fluid

Used exclusively by Red Devil for longer lasting calipers. #RED 1032 \$35.00



Super Hi-Temp Dot 5.1 Brake Fluid

This fluid will withstand even the toughest drivers on brakes. There simply is no better fluid. Non-silicone based so will mix with anything. #APF BKF \$17.99

Wilwood 570 Brake Fluid

Wilwood's standard brake fluid. Built for cooler temperature braking applications. An economical fluid that will mix with anything. #WIL 290-0632 \$5.99



Exp 600 Plus

Exp 600 Plus is a highly refined blend developed for extreme performance under the high heat and extreme pressure of professional motorsports. #WIL 290-6209 \$19.99

Pre-made Stainless Steel Flex Line Chart

Size	Length	Fittings	Part #	Price
#3	5"	St.	BKL 3-5	\$12.99
#3	15"	St.	BKL 3-15	\$14.99
#3	16"	St.	BKL 3-16	\$14.99
#3	18"	St.	BKL 3-18	\$14.99
#3	21"	St.	BKL 3-21	\$14.99
#3	21"	St. 90	BKL 3-21-90	\$19.99
#3	24"	St.	BKL 3-24	\$14.99
#3	24"	St. 90	BKL 3-24-90	\$19.99
#3	28"	St.	BKL 3-28	\$19.99
#3	30"	St.	BKL 3-30	\$19.99
#3	36"	St.	BKL 3-36	\$19.99
#3	48"	St.	BKL 3-48	\$24.99
#4	12"	St.	BKL 4-12	\$15.00
#4	15"	St.	BKL 4-15	\$15.00
#4	16"	St.	BKL 4-16	\$15.00
#4	18"	St.	BKL 4-18	\$15.00
#4	18"	St. 90	BKL 4-18-90	\$19.99
#4	20"	St.	BKL 4-20	\$15.00
#4	22"	St.	BKL 4-22	\$15.00
#4	24"	St.	BKL 4-24	\$15.00
#4	28"	St.	BKL 4-28	\$15.00
#4	36"	St.	BKL 4-36	\$19.99



Wilwood Front Brake Pad

Used for all types of rotors- any brand. Also used for rear brake on 600 mini sprints.

Aluminum Rotor: #WIL 15Q-10144 \$13.99

Steel Rotor: #WIL 15B-9819 \$15.99

Ti Rotor: #WIL 150-4756 \$27.99



Brakeman Sprint Car #2 Front Brake Pad

Excellent stopping power for any steel rotor. Aggressive yet easy on rotors.

#BRA 201R \$16.99



Red Devil Front Pad

Use on any titanium rotor. Unique patented construction.

#RED UL-104 \$26.95

3/8" OR 1/2" ROTORS



.810 ROTORS



Wilwood Wide Rotor Inboard Pad

All Wilwood 4" Lightweight Calipers now use the same inboard brake pad. Wilwood lightened up the backing plate and built the pad to accept the new 3 position clip that comes with the 2008 calipers. Same great stopping power and consistency.

Steel .810 Rotor #WIL 15B-7264 \$24.99

Steel Narrow Rotor #WIL 15B-9836 \$24.99



Red Devil Inboard Brake Pad

A must have with all coated rotors. The ultimate in stopping power! Fits wilwood NDL & Red Devil Featherlite systems. Other configurations available too.

#RED UL-200 \$40.00



Red Devil Asphalt or Midget Front Pads

#RED UL-300 \$35.95



Wilwood Asphalt Sprint & Midget Inboard Pad

Designed for 4 piston front calipers & rear 1200 mini sprint or midget calipers. Steel rotor application. Thin Pad for narrow clearance(most common)

Steel Rotor #WIL 15B-3991 \$19.99

Ti Rotor #WIL 150-8450 \$39.99

Pro Ultimate Aluminum Shocks

Look at most of the top Sprint teams throughout the nation and you will see they are running Pro Shocks. We stock many of the popular valvings. Available in large smooth or threaded body. Small smooth or threaded body, and rebound adjustable in small or large body.

7"	Compressed Length	Extended Length	8"	Compressed Length	Extended Length
A740B	12.5	19.5	A840B	13.5	21.5
A750B	12.5	19.5	A850B	13.5	21.5
A760B	12.5	19.5	A860B	13.5	21.5
A746B	12.5	19.5	A838B	13.5	21.5
A757B	12.5	19.5	A8313B	13.5	21.5
			A846B	13.5	21.5
A752B	12.5	19.5	A847B	13.5	21.5
A753B	12.5	19.5	A8410B	13.5	21.5
A762B	12.5	19.5	A8412B	13.5	21.5
			A849B	13.5	21.5
			A856B	13.5	21.5
			A857B	13.5	21.5

Aluminum Smooth Large Body



\$147.99

Afco Small Body Shocks

AFCO small body aluminum shocks have proven to be winners all over the country. So Afco went to work redesigning their aluminum small body. This shock provides the advantage you have been looking for and the consistency any racer needs. Superior feel with a valving curve that allows for the driver to have direct connection to what the car is doing. Many other shocks will fall off as the car travels at increased speeds. Afco Small Bodies maintain their feel throughout the shock curve.

#AFC 16xx
\$156.99

NEW!

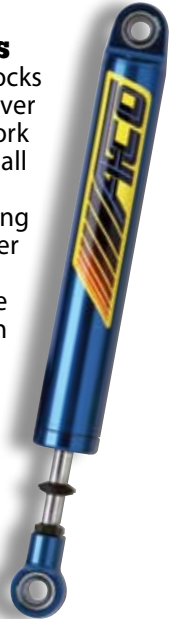

Small Body Aluminum Shocks

7" Stroke (Sprint Frt, Midget, 1200 Mini Sprint)		8" Stroke (Sprint Rear)	
Compressed Length 12.38		Compressed Length 13.38	
Extended Length 19.75		Extended Length 21.75	
Part #	Valving	Part #	Valving
8273	3	8283-8	3-8
8273-1	3-1	8284	4
8274	4	8284-6	4-6
8274-6	4-6	8284-7	4-7
8274-7	4-7	8284-8	4-8
8275	5	8285	5
8275-2	5-2	8285-6	5-6
8275-3	5-3		
8275-4	5-4		
8276	6		
8276-2	6-2		



82 Series
\$167.95

40% lighter than full size shocks!



QA1 Aluminum Mini Sprint Shocks

The most economical shock to have on your sprint car is the QA1. The shocks are precision built for repeatability, they don't fade, and the valving stays consistent throughout their life span. QA1's can be mounted in any direction and have ribbed exteriors for superior cooling. The shocks are completely owner Re-valveable and Re-buildable. All of the parts are available to rebuild them if you damage them in any way.

#QA1 82xx \$167.95

Pro Rebound Adjustable Shocks

The ultimate in Adjustable Shocks. We stock the compression set at 3 or 4 with two different rebound ranges. You will love the ability to adjust the shock as the night progresses.

A simple dial allows you to adjust it on the fly.

- #PRO A8338B (3 Comp, 3-8 Rebound)
 - #PRO A83611B (3 Comp, 6-11 Rebound)
 - #PRO A8438 (4 Comp, 3-8 Rebound)
 - #PRO A84611B (4 Comp, 6-11 Rebound)
 - #PRO A84.53-8B (4.5 Comp, 3-8 Rebound)
 - #PRO A853-8B (5 Comp, 3-8 Rebound)
- \$295.99



Afco Double Adjustable Sprint/Mini Sprint Shock

The M2's ability to keep the tires in compliance with any track surface condition from tacky to slick, bumpy to smooth, rutted to washboard, lies in its combination of low friction and fast reacting components. Working together, all the parts of the M2 provide unparalleled seat-of-the-pants feel for the track, consistency, and TRACTION.

Flexible Gas Bladder Design

The M2's gas inflated bladder is able to compress and expand at incomparably high speeds, very slow speeds, very small movements and large deflection all at the same time with virtually no resistance or friction. This allows it to react to the most minute high frequency chatter, while still providing positive control of weight transfer during transitions on the track.

Adjustment Range

The M2's design allows it to perform in ways other shocks cannot. The M2 provides an unparalleled range of adjustment & performance abilities. Due to its unique design, the adjustments you make with the M2 have a very large effect on handling.

The M2's mono-tube, gas pressure design coupled with its superior valve design and use of gas charged bladder provide real, substantial control of compression and rebound resistances throughout the entire velocity range. This means the M2's adjustments are much more pronounced and provide more sensitive & extended low speed adjustments for increased effective tuning range.

Low Gas Pressure

The M2 remains hyper-sensitive at significantly lower gas pressures than the competition. This gives you the advantage of being able to run a MONO-TUBE shock and achieve TWIN-TUBE shock feel & characteristics.

Easy To Use & Accurate

The adjusters on the AFCO M2 are specifically designed to make fast, precise, and repeatable changes. The knobs are 100% O-ring sealed from the elements and easy to grasp, even with muddy, greasy, or gloved hands. The easy-to-feel, spring-loaded detents allow you to quickly change with a

NEW!

THE ULTIMATE WEAPON

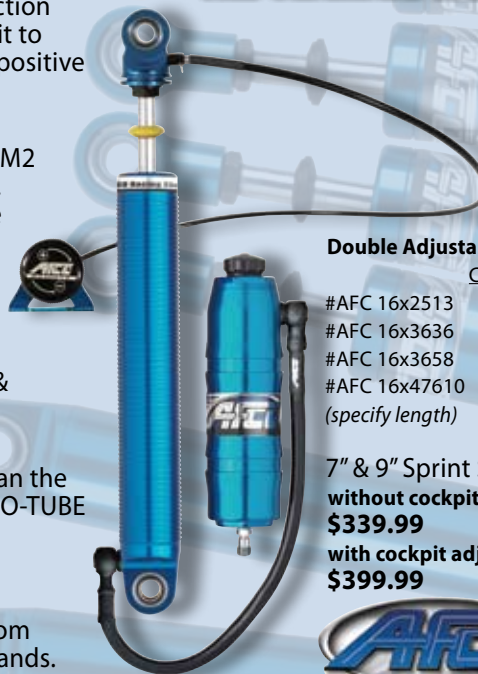

Double Adjustable Ranges

	Comp	Reb
#AFC 16x2513	2-5	1-3
#AFC 16x3636	3-6	3-6
#AFC 16x3658	3-6	5-8
#AFC 16x47610	4-7	6-10

(specify length)

7" & 9" Sprint Shock
without cockpit adjuster
\$339.99
with cockpit adjuster
\$399.99



Afco Edge Complete Shock Packages

NEW! EDGE Sprint Car/Mini Sprint Packages - (Now available in 6" & 8" Packages, as well as 7" & 9")

Winning reputations aren't given – they're earned. Tireless testing and development have earned AFCO a reputation for offering the best-performing Sprint Car shock line on the track, with multiple championships in USAC and the World Of Outlaws as a result. Now, with the help of many champion drivers, AFCO has developed an all-new line of EDGE Sprint Car/Mini Sprint Packages, available now!

The EDGE Sprint/Mini Sprint Packages are more than just boxes of shocks. Each of the 11 shocks in these packages is designed to provide specific rebound and compression dampening at both low- and high-speed shaft velocities to maximize handling for specific track conditions. Each package also includes a comprehensive tuning guide that shows you exactly which shocks go together to make all four corners of your car perfect for any track condition – whether it's dry, slick, heavy or rough.



EDGE VALVE



NEW!

- 11-Shock Package, Wing Cars (7" & 9")**
\$1759.99
- 4-Shock Slick Track Package, Wing Cars (7" & 9")**
\$639.99
- 11-Shock Package, Non-Wing Cars (7" & 9")**
\$1759.99
- 4-Shock Slick Track Package, Non-Wing Cars (7" & 9")**
\$639.99



Titanium Quick Pin Shock Kit

A complete kit to fit most late model chassis. Comes with nuts, spacers, clips, and studs. Mounts a complete set of shocks to car.
#AST 1256 **\$191.99**

Afco Shock Bumper Kit



The most popular shock bumper on the market. Flush mount aluminum washer and medium/soft 2 3/4" bumper.
#AFC 20174 **\$25.99**



Titanium Shock One Nut Studs

One nut on the front side of the stud that you actually take on and off, but the other side is fixed so only one ratchet is needed. You will love these. In stock for Rocket thread in front axles. We also sell other combinations for your chassis.
#AST 1253 **\$172.99**

Steel Heim for Tie Rods & Drag Links

- Carbon Steel
- Protective coated for corrosion resistance.

Heim: #QA1 EXMR8-10 **\$14.00**
Jam Nut: #QA1 JNR10A **\$0.95**



Rear Arm Heim

- Chrome Moly Steel
- Heat treated
- Protective coated for corrosion resistance

Heim: #QA1 XMR8-10 **\$22.95**
Jam Nut: #QA1 JNR10A-LG **\$1.75**



Eibach Spring

The finest springs available today. Guaranteed to be built within 2% for life. Eibach springs are metric sized and, therefore, not limited to the SAE sized wire used in the production of many of the springs currently on the market. Used by many of the top teams. Available in 2 1/4 ID or 2 1/2 ID and 8" or 10" long.

8": #EIB 800XXX **\$63.99**
10": #EIB 100XXX **\$63.99**



Afco Coil Springs

- Perfect fit for open wheel, dwarf cars, and other applications that require 1 7/8" I.D. Springs
- Made to the same specifications as all AFco Coil-overs
- Fits small body shocks
- Lifetime warranty
- 8" or 10" free height

#AFC COILx **\$64.99**

Hyperco Coil Springs

The most versatile spring for sprint cars. Many rates and sizes available. We stock them in 1.875", 2.25" I.D. Available in rates from 75 to 400 Lbs depending on I.D. and overall length.

From \$69.99



Chromoly Heim Spacers

#KRP 2845-5 **\$6.99**

Sold in convenient 5 packs! **NEW!**

Aluminum Shock Spacers

Only .200 Thick, perfect for shock heim movement throughout the car.

Sold in 10 packs.
#KMI SSK **\$11.50**



Aluminum Heim Spacers

#BPW 0804A **\$1.25**



Aluminum Rod End

Aircraft Aluminum 7075-T6

Color Anodized

2 Piece Construction

Red, Silver or Black Available

\$13.99

Aluminum Jam Nut

\$9.95



King Bolt on Shock Towers

Every traveling team should have these in their tool box in case of an emergency. Get in a wreck and you can run with a coil over shock on the right or left front with one of these 4130 chromoly shock towers bolted on your car even if the torsion bar tube is destroyed.

#KRP 2355 **\$42.99**





Large Body Tuning Kit

For FC, 50, 60 and 62 Series Shocks
Tuning kit contains:

- (4) pistons • Seal kit for (4) shocks
 - (2) base valves for 0 - 5 valvings
 - (2) base valves for 6 - 13 valvings
 - Assortment of deflective discs
 - Drill bits • Easy-to-follow instructions
- #QA1 TK01 **\$144.95**



QA1 Shock Oil

Specially formulated for use with QA1 shocks.
#QA1 SF01 **\$9.95**



Small Body Tuning Kit

For 70 and 82 Series Shocks
Tuning kit contains:

- O-rings, seals, wipers
 - Assortment of deflective discs
 - Easy-to-follow instructions
- #QA1 TK02 **\$144.95**



QA1 Shock Wrench

Make QA1 shock work a snap with this wrench. The spanner wrench takes the closure nut off, the box end removes the nut on the shaft. No other tools necessary.
#QA1 7791-104 **\$19.95**



JOES Small Body Shock Wrench

Perfect for working on your shocks. One wrench takes the whole shock apart!
#JOE 19085 **\$48.99**

All new shaft holder cutout!



NEW!

Shock Working Vise

JOES makes this handy vise for working on any take apart shock. Hold the body on one side, and the shaft on the other.

#JOE 19200 19250 **\$219.99**

Coil Over Adjuster Wrenches

We've got one with a short and long handle for more leverage.

Std. #JOE 33000 **\$39.99**
Long #JOE 33500 **\$39.99**



Coil-Over Kit

Contains:

- Spring cap
- Spring seat adjuster nut
- 2 wire ties
- 1 spring cap retainer pin

For threaded aluminum 82 & 62 series only. Kit includes components for one shock.
#QA1 CK6201 **\$36.15**
#QA1 CK8201 **\$36.15**

AUTHORIZED AFco REBUILDER

SpeedMart is proud to announce the convenience of rebuilding your Afco shocks! We will be sending our staff back to Afco to be trained to produce the perfect Afco shock every time. Stay tuned as we add this feature to our already full service speed shop!



NEW!



JOES QA1 Drip Cup

Tired of the mess of working on shocks? Before beginning your shock work, simply install this drip cup over the body of the shock and you are in business! No more oil dripping off of your table.
#JOE 19300 **\$49.99**



Titanium Tie Rod/ Drag Link Kit

All 4 studs needed to connect your tie rod and drag link to front end and pitman arm. A great addition to the shock and radius rod kits. Super strong!
#AST 1259 **\$76.99**



Sprint Car Radius Rod Kits

Complete Radius Rod Kit
12 QA1 Aluminum Heims, Jam Nuts, and 6 Polished Radius Rods
#SMI K-RR8xR (specify car length-see below) **\$239.99**
Complete Kit Including Drag Link and Tie Rod with QA1 Steel Heims on Drag Link.
12 QA1 Aluminum Heims, 4 Steel Heims, Jam Nuts, 6 Polished Radius Rods, 1 Tie Rod, and 1 Drag Link
#SMI K-RR8xCS (specify car length-see below) **\$339.99**



XXX Anodized Black Aluminum Radius Rods

Length: 18" - 24" (select size)
#TRX SC-SU-0010B **\$11.45**

Complete Sway Bar Kit

Sprint Sway Bar Kit-Used by all non wing cars for front end stability. A bolt on system that fits on Eagle, Maxim, Rocket, and Schnee Chassis. Sold complete with arms, heims, rods, and frame addition. Look at all of the pictures of the USAC winning non wing cars, all of them have it.
#ROC K-SWBAR **\$559.99**

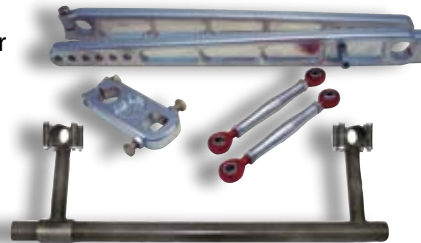

Titanium Radius Rod Stud Kit

Same style as the shock kit. Only one wrench needed to take a rod off of your car. Great in a thrash. We also sell these kits in quick pin configurations. 6 Rod Bolts and 3 to hold the front rods onto the front axle.
#AST 1257 **\$169.99**

Swedged Aluminum Radius Rods

We stock 18-1/2" through 24-1/2" for all makes of cars. Made from 1-1/8" aluminum for strength. For drag links and tie rods we carry 45"-52" made from 1-1/4" aluminum. Custom lengths available for any application.

0-24" 1-1/8 **\$11.99**
24 1/2-39" 1-1/8 **\$16.00**
40-54" 1-1/4 **\$22.00**



RECOMMENDED RADIUS ROD LENGTHS

Chassis	Length	Panhard	LF	RF Top	RF Bottom	LR	RR	Drag Link	Tie Rod
Rocket	40/88	18.5	23.5	24	24	23.5	24	50	46
Rocket	40/87	18.5	22.5	23	23	23.5	24	49	46
Rocket	40/86	18.5	21.5	22	22	23.5	24	48	46
Maxim	40/86	18.5	21	21.5	21.5	23.5	24	48	45.5
Maxim	40/87	18.5	22	22.5	22.5	23.5	24	49	45.5
Eagle	40/86	18.5	21.5	21.5	21.5	23.5	24	48	46
Eagle	40/88	18.5	23.5	23.5	23.5	23.5	24	50	46
XXX	40/88	18.5	23.5	24	24	23.5	24	50	46
XXX	40/87	18.5	22.5	23	23	23.5	24	49	46
J&J	40/87.5	19	22.5	22.5	22.5	23.5	24	50	45.5
J&J	40/88.5	19	23.5	23.5	23.5	23.5	24	51	45.5

4130 Tie Rod and Drag Link

1 1/8" chromeoly material with high strength inserts and CNC threads so heims won't jam in the ends. Powder coat ready.
\$36.95



XXX 13 5/8" or 14" Bare Watts Link

Sprint Car Jacob Ladder. Plated. No straps or hardware (bolts). Jig built for quality and exact fit. Specify Size When Ordering.
#TRX SC-SU-0002 \$36.00

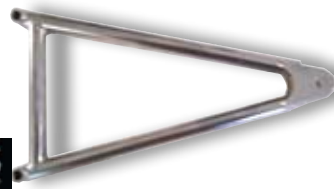

Steel Tubular Watts Link

Made from 4130 chromeoly tubing. Will resist bending or braking better than any aluminum W-Link. Each link built in a fixed jig for accuracy.

13 5/8" Key: #ROC WL1358 \$47.50
13 5/8" Complete: #ROC A-WL13558 \$65.00

14" Key: #ROC WL14 \$47.50
14" Complete: #ROC A-WL14 \$65.00



J & J 3 Hole and Standard Watts Links

Precision built like everything at J & J. 3 hole adjustable configuration is the quickest way to tighten or loosen your race car.
 3 hole #JNJ 104015 **\$84.99**
 Standard #JNJ 104014 **\$69.99**

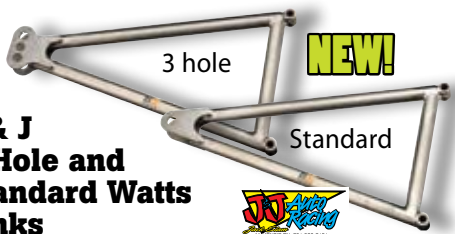

SpeedMart Watts Link Strap 4 Pack

4-pack of lightened and radiused watts link straps.
#MNW JLS-7 \$9.95



Watts Link Spacer Spring Set

Regular spacers tend to prevent your watts link from moving freely. These springs allow your w-link to travel without resistance.
#SMI WLSPRG \$2.00



XXX Race Company Plated Chromeoly Tie Rod and Drag Links

4130 Chromeoly Tubing and plated for polished appearance. 1 1/8" in diameter with 5/8" heim threads. The best value on the market! Available in 45 3/4" through 51".
#TRX SC-SU-0200 \$28.95
 Specify Length

XXX 13 5/8" or 14" Complete Watts Link

13 5/8" Jacob Ladder Complete (with straps). Nuts/Bolts not included. Plated. Jig built for quality and exact fit. Available with CNC'd Lightweight Straps or Standard Straps. Specify Size When Ordering.
13 5/8: #TRX SC-SU-0004 \$42.00
14: #TRX SC-SU-0008 \$42.00



Titanium Watts Link Pin Kit

Easy to change in a wreck and really light! All pieces provided to make installation a snap.
3/8" Car 1/2" Watts Link #AST 951 \$47.99
3/8" Car 3/8" Watts Link #AST 950 \$47.99

Jacobs Ladder Quick Pin Kit

This handy kit is great for changing watts links quickly in a crash. Especially nice with the long kick panels of today!
#FAS JLPK1 \$15.99





Winters Performance Bird Cage Set

Winters Performance bird cage set (left and right birdcage). Aluminum. Black powder coat. Complete with bearings, torsion arm bolts (with washers), and radius rod bolts. Light weight and super strong. #WIN SC2575 **\$338.95**



King Lightweight Birdcages

Guaranteed against any and all breakage for one year! Solid lower flag construction allows your rear arms to stay stable through bumps and severe chassis load. Available in Black powdercoat. #KRP 1705 **Left \$226.99**
#KRP 1710 **Right \$226.99**



SpeedMart Rear Axle Birdcage Level

The most important tool in your collection! Top pin centers into predrilled bolt in your birdcage (we can supply you one no matter what kind of cage you have), and precision level on top rotates as you square your rear end. There is no substitute for these guys. Every team must have one. #KMI BCLEVEL **\$69.95**

KRP Quick Reference Birdcage Level

Need a quick leveling at the race track? Snap this handy plastic birdcage level on your axle and over the shoulder of the bolt and you are there! #KRP 1780 **\$19.99**

NEW!



Ti22 Adjustable Birdcage Set Complete

The newest invention in sprint car racing! Machined from 7075-T6 aluminum with a 28mm double row angular contact bearing. Ti22 birdcages have an adjustable ladder pickup option for adjusting the roll center quickly and precisely. Accepts a standard watts link and has adjustments in 1/8" increments. #T22 1079/1081 **\$539.99 set**

NEW!



SpeedMart Birdcage Tool

Designed by a race car owner who damaged his birdcages trying to get his birdcage bearings in. With this tool you will be able to drive the bearings in and out straight, preventing them from bending the cages or forcing them out of round. #KMI BCT **\$55.99**



DMI Lightweight Angular Contact Birdcage Set

Solid flag construction for chassis stability, and built from 7075-T6 aluminum for added strength. All birdcages have brake brackets built right in. #DMI SRC-2575 **\$399.99**



Angular Contact Birdcage Bearing

The most common birdcage bearing used today. We stock both sizes that are used in birdcages for sprint cars. One of them measures 1 1/8" wide and the other measures 1 1/4" wide so measure first before you order. #SUP D5914RS **\$54.95**



1 1/4 wide #SUP D5914RS 1 1/8 wide #SUP 5914RS

LW Birdcage Bearing

The smallest & lightest birdcage bearing for sprint cars. We tested many brands to come up with this one. It's super durable! Fits 1999-2002 LW birdcage sets. #SUP 69142RS **\$24.95**



Winters Birdcage Spacers

Hardened steel spacer for the right side of the rear axle behind the birdcage. You must have one or the force of the birdcage will dig into the rear axle surface. #WIN 6156 **\$9.99**

Splined side



STD Birdcage Bearing

Used by many different birdcage manufacturers. Almost all STD birdcages use this bearing. #SUP 6014RS **\$18.00**



King Front Torsion Arms

After looking at pictures of many sprint cars throughout the country, King noticed that many front arms flex. These are designed not to flex and still be light enough for a top notch sprint car. Available in black anodized, too!

Right Front #KRP 1100

\$50.00

Black #KRP 1105 \$59.99

Left Front #KRP 1110 \$60.00

Black #KRP 1115 \$65.99



NEW!



DMI Front Torsion Arms

DMI makes the most durable arms around. Lightened, but only partially through the arm for the ultimate strength.

#DMI SRC-2120 LF

#DMI SRC-2130 RF

\$52.99



NEW!

LRB Front Arms

The strongest front arms on the market. Anodized black and machined after for a really great finish. Made blunt on the axle side to prevent front axle damage.

#LRB Arxxx \$62.99

(specify right or left)



NEW!



J & J Torsion Arms

Built to fit your late model J & J perfectly. Why buy anything else, buy what fits.

Front Arms #JNJ 10200x \$53.99

(specify right or left)

Rear Arms #JNJ 10200x \$65.99

(specify right or left)



XXX Front Torsion Arms

Brand new for 2009! XXX aluminum or powder coated black front torsion arms. Lightweight and strong! Complete with bolts.

Right Front #TRX SC-SU-0116 \$41.50

Black #TRX SC-SU-0116B \$43.50

Left Front #TRX SC-SU-0115 \$41.50

Black #TRX SC-SU-0115B \$43.50

Winters Front Arms

Winters Performance front torsion arms. Aluminum. Polished. Complete with bolt.

Light weight and super strong.

#WIN SC2120L

\$41.95

#WIN SC2130R

\$41.95



Offset Left Torsion Arm

Allows drivers to turn farther right. Vital to a non-wing car.

#DMI SRC-2115 \$59.99



XXX Rear Torsion Arms

Brand new for 2009! XXX aluminum or powder coated black rear torsion arms. LR bend is 2 1/4", RR bend is 4" from outer edge to rod end centerline. Complete with bolts.

Right Rear #TRX SC-SU-0118 \$59.95

Black #TRX SC-SU-0118B \$61.95

Left Rear #TRX SC-SU-0117 \$59.95

Black #TRX SC-SU-0117B \$61.95



Lightweight

Rear Arms

Replacement arms available for Eagle, Rocket & Maxim. These arms resist twisting and hold up great! Ultra-light too!

#ROC ARMLR \$69.00

#ROC ARMRR \$69.00



DMI Rear Torsion Arms

Simply the strongest rear arms made. These will line up perfectly with any large bearing birdcage and late model chassis. Once guys put these on, they won't change.

#DMI SRC-2687 (left)

#DMI SRC-2689 (right)

\$61.99

Winters Rear Arms

Winters Performance rear torsion arms. Aluminum. Polished. Complete with bolt. Light weight and super strong.

#WIN SC2689L \$61.99

#WIN SC2686R \$61.99



Zemco Torsion Bar Bushings

Made from high density plastic, these bushings install with no tools. Torsion bars slide in with ease!
.095 (All newer sprint cars)
 #ZEM 095 \$5.50
.120 #ZEM 120 \$5.50



4 or more \$75.95

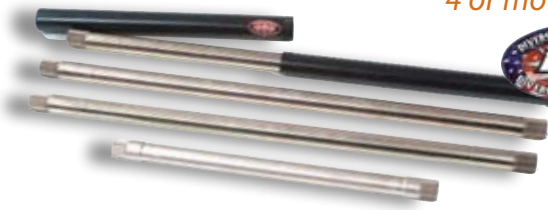

Torsion Bars

Bar starts out as 4340 heat-treated material, then CNC machined to specs and tolerances of ±001. The bar is straightened twice during the machine process to assure trueness. If you are looking for consistency, we've got it. The best torsion bars made!
\$79.99

Sanders X Bar

Rifled Drilled Special Material and not manufactured anywhere else but Sanders. These are by far the most exact rated torsion bars on the market. There is no substitute for their longevity. Once you have switched to a Sanders X Bar, you will never buy anything else.
 #SAN XBAR (Specify rate) **\$144.99**



MNW T-Bars

New to the market in 2008 and built right! We have sold these to our pickiest teams and have had great luck. Drivers report repeatability and great feel. Take them out after a season, and they still test great!
 #MNW TBxxx \$84.99



Brass Torsion Bar Bushings

Sometimes plastic bushings aren't tough enough on the older cars when the tubes get out of round. Specify .095 or .120 tubes.
.095: #DMI SRC-2210 \$5.99
.120: #DMI SRC-2211 \$5.99



King Torsion Bar Reamer

The best torsion bar reamer on the market. Complete with all tools needed to align your torsion bar bushings perfectly. 3/4" hex socket built right for your impact gun. A little WD-40, a 3/4" socket, 8 bushings, and you are in business!
 #KRP 2500 **\$178.99**



SpeedMart
 gettin' it done fast



Alum Torsion Stop

The choice of most racers for front torsion stops.
 #DMI SRC-2140 **\$32.99**



Mettec Steel Stops

These rear stops are the best! Tighten them for years and they will still slide right on and off the torsion bars! Super strong!
 Available in 1 3/4 & 2" split.
 #MET STOPST-7 **\$29.95**

6AL-4V Titanium Torsion Stop

The best value in titanium stops! 1 3/4" Split
 #BEN TTS **\$159.99**

Titanium Torsion Stop Bolt w/Jam Nut

1/2 the weight of steel torsion stop bolts, & they last twice as long. Won't stick or ruin the threads in aluminum torsion stops either!
 #AST 5719 **\$15.99**



Alum 5/8 Stop Adjuster Nut

A must have! Use the same size wrench for your torsion bolt and nut.
 #AST 1006 4pk **\$7.99**



Steel Torsion Stop Bolt and Nut

Very important to keep an eye on these as they wear down. Once they become too worn, you will not be able to change them. Cheap insurance.
 #DMI SRC-2159 **\$5.99**

NEW!



FRONT RIMSHELL

	Size	Offsets	Non Beadlock	Beadlock	B/L w/cover
250 & 600 Mini Sprint	10 x 7	3,4	\$133.99	x	\$231.99
1200 Mini Sprint	13 x 7	3,4	\$230.99	x	\$318.99
Midget Front	13 x 8	3,4	\$173.99	x	\$323.99
Sprint Front	15 x 8	3,4,5	\$190.99	x	\$347.99
Asphalt	15 x 10	3,4,5,6,7	\$198.99	x	x

SPLINE

Mini Sprint/Midget	Size	Offsets	Non Beadlock	Beadlock	B/L w/cover
27 Spline Mini	10 x 9	4	x	\$288.99	x
27 Spline Mini	10 x 10	4	x	\$294.99	x
27 Spline Mini	10 x 12	5	x	x	\$318.99
31 Spline	13 x 8	4,5	x	\$410.99	x
31 Spline	13 x 10	1,2,3,4,5	x	x	\$442.99



SPRINT SPLINED REARS

Size	Offsets	Non Beadlock	Beadlock	B/L w/cover
15 x 15	5,6	x	\$499.99	x
15 x 16	5,6	x	x	\$528.99
15 x 17	5,6,7	x	x	\$534.99
15 x 18	5,6,7	x	x	\$540.99

NEW!



FRONT RIMSHELL

	Size	Offsets	Non Beadlock	Beadlock	B/L w/cover
250 & 600 Mini Sprint	10 x 7	3,4	\$86.99	x	\$176.99
1200 Mini Sprint	13 x 7	3,4	\$187.99	x	\$258.99
Midget Front	13 x 8	3,4	\$158.40	x	\$264.99
Sprint Front	15 x 8	3,4,5	\$153.99	x	\$275.99
Asphalt	15 x 10	3,4,5,6,7	\$166.99	x	x

SPLINE

Mini Sprint/Midget	Size	Offsets	Non Beadlock	Beadlock	B/L w/cover
27 Spline Mini	10 x 9	4	x	\$228.99	x
27 Spline Mini	10 x 10	4	x	\$230.99	x
27 Spline Mini	10 x 12	5	x	x	\$265.99
31 Spline	13 x 8	4,5	x	\$275.99	x
31 Spline	13 x 10	1,2,3,4,5	x	x	\$322.99



SPRINT SPLINED REARS

Size	Offsets	Non Beadlock	Beadlock	B/L w/cover
15 x 15	5,6	x	\$387.99	x
15 x 16	5,6	x	x	\$422.99
15 x 17	5,6,7	x	x	\$422.99
15 x 18	5,6,7	x	x	\$428.99



FRONT RIMSHELL

	Size	Offsets	Non Beadlock	Beadlock	B/L w/cover
250 & 600 Mini Sprint	10 x 7	3,4	\$93.95	x	\$217.95
1200 Mini Sprint	13 x 7	3,4	\$175.95	x	\$335.95
Midget Front	13 x 8	3,4	\$175.95	x	\$335.95
Sprint Front	15 x 8	3,4,5	\$185.95	x	\$282.95
Asphalt	15 x 10	3,4,5,6,7	\$203.95	x	x

SPLINE

Mini Sprint/Midget	Size	Offsets	Non Beadlock	Beadlock	B/L w/cover
27 Spline Mini	10 x 9	4	x	\$294.95	x
27 Spline Mini	10 x 10	4	x	\$300.95	x
27 Spline Mini	10 x 12	5	x	x	\$317.95
31 Spline	13 x 8	4,5	x	\$424.95	x
31 Spline	13 x 10	1,2,3,4,5	x	x	\$465.95



SPRINT SPLINED REARS

Size	Offsets	Non Beadlock	Beadlock	B/L w/cover
15 x 15	5,6	x	\$417.95	x
15 x 16	5,6	x	x	\$444.95
15 x 17	5,6,7	x	x	\$454.95
15 x 18	5,6,7	x	x	\$463.95

SPRINT CAR DIRT

Front

85.0/8.0-15 D12/D15

Left Rear

90/15.0-15 D10 / RD12 / D12

92/15.0-15 D10 / RD12 / D12

94/15.0-15 D10 / RD12 / D12

96/15.0-15 D10 / RD12 / D12

Right Rear

105/18.0-15 SC-15

West Coast Spec Right Rear

105/16-15 Med

ASCS Right Rear

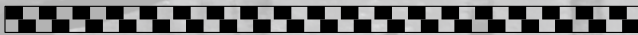

Weld Valve Stems

Designed for Weld and Sanders. Hard to find at your local tire shop for this price! Use small stem for front or mini sprint wheels.

Std: #WEL VLVSTM \$3.00

Small: #WEL VLVSTSM \$3.00



Aluminum Bleeder Check Tank

Compact tank allows you to accurately set regular and diaphragm axle bleeders perfectly every time. Built in tray for storage, too.

#FSR 122853 \$119.99

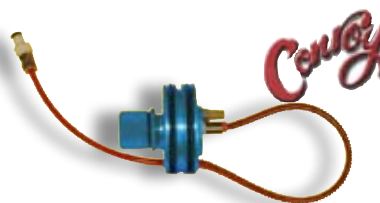

Conroy Diaphragm Bleeder Set

The bleeder works on the same principle as a High Speed By-Pass. Preset spring pressure against a Diaphragm that controls the amount of air that is to pass through the port. It releases air instantly in a 360 degree pattern. You don't have to compensate for what you think it may bleed off at. It repeats within 2/10 of a pound. With 4 different Springs, it has a range of 2 to 30 pounds.

#CON xxx-DIA \$349.99

Conroy Bleeder Repair Kits

All of the stuff that breaks in one kit

Diaphragm Kit

#CON DRK \$59.99

Standard Kit

#CON RK \$47.99



Specify Axle type - Midweight or Lightweight

Conroy Replacement Hose

#CON PLYHS \$10.99



Kwik Change Bleeder Sealing Washers

#KCP 713-005 \$4.99



Conroy Muffler

Required on the diaphragm bleeders, and a very weak link. If this gets broken off, dirt can get into the bleeder, making a mess out of it internally.

#CON MFLR \$6.99

Kwik Change Shrader Valve

Eliminate the valve stem for rotating weight savings. Just put this in your wheel insert to air up tire. No leaky valve problems either!

#KCP 713-002 \$12.99



Conroy Replacement Diaphragm

#CON RDIA \$8.99



Conroy Hose Connectors

Replacement hose connector for center of diaphragm bleeder.

#CON HSCNT \$22.99



Conroy Replacement O-Ring

Very hard to find o-ring for diaphragm bleeder assembly.

#CON ORING

\$1.99



Conroy Rear Axle Bleeders

Bleeders inside of the wheel will stay closed even if the pressure is over their limit just because of the centrifugal force of the wheel spinning. This kit puts the bleeder itself inside of the axle so it has no force acting against it. The hose connects the bleeder to the wheel allowing it to bleed off at the pressure it's set at.

(Specify axle size when ordering)

\$179.99

Bleeder Screens

The new diaphragm bleeders are extremely sensitive to dirt and debris. These screens install in the bleeder housings inside the wheel and block dirt from getting into the bleeders. Do not run diaphragm bleeders without them.

#CON SCRIN \$6.99



Saldana Wheel Wrench

The best wheel wrench on the market! Comes with adaptors for all three weights of axles.

- #SAL WW-S \$161.99
- #SAL WW-M \$139.99
- #SAL WW-MS \$131.99



Kwik Change Bleeder Starter Kit

4 wheel inserts & 4 bleeders. What a kit! Gives you the ability to have your stagger combinations preset.

#KCP A-223-70 \$124.99



Kwik Change Wheel Bleeders

Pre-set them in the shop & keep them in a bag in your tool cart, just like the pros.

#KCP 713-100 \$18.99 ea.



DMI's Black Widow Replacement Wheel Center

The only way to go with replacing a crashed wheel center. Fits Weld and Sanders wheels perfectly. Stronger than the manufacturers originals.

#DMI SRC-1979A \$136.99

Kwik Change Next Generation Bleeder Kit

A little more expensive but twice as accurate. Two springs inside which are adjustable for higher pressures. A must have for asphalt racers.

#KCP A-714-1002 \$54.99



Kenny's Components Carbon Fiber Wheel Covers

The strongest wheel cover made. Kenny's carbon fiber is very high quality and highly glossed for a very pristine look. Complete when you receive them and ready to bolt on.

- #KEN WWC-15 \$134.99
- 10" #KEN WWC-10 \$59.99



Kwik Change 4 Pack Wheel Inserts for Bleeders

The one thing everyone forgets when they buy a new wheel. Nice to have around for spares.

#KCP A-713-158 \$48.99



New Generation Bleeder Starter Kit

4 New Generation Bleeders and 4 Wheel Inserts. The kit we sell the most of for today's cars. High speeds are forcing most teams to go to these higher quality bleeders.

#KCP A-223-701 \$169.99

Kwik Change Bleeder Repair Kits

Don't throw your bleeders away if they aren't accurate. This kit repairs 4 bleeders. Just specify black or red bleeders when ordering.

- Black: #KCP A-713-006 \$13.99
- Red: #KCP A-713-006NG \$16.99



Weld New Generation Mud-cover

Designed for appearance and functionality. All bolts are completely covered. Mud will not gather in between and cause wheel to be off balance.

- #WEL P650-4014A 10 inch \$33.95
- #WEL P650-4314A 13 inch \$37.95
- #WEL P650-4514A 15 inch \$42.95



NEW!

Lightweight Black Anodized Driveline Kit

Our own lightweight kit with simply the best combination of components for your sprint car. The King Racing Products Torque Ball and Housing fits perfect and has awesome movement with almost no play. We tested them all and this one was the best! The LRB Torque Tube is a perfect fit inside the King Torque Ball. Kit comes complete with a DMI Hollow Steel Driveshaft. Entire kit weighs 14.25 pounds.
#SMI K-DLLW **\$599.99**

LRB Torque Tube

Shiny anodized black, Ultralight, and a perfect fit for LRB, VMAC, DMI, or Sanders Torque Ball Housings. Long torque tube collar with lightning spots everywhere for weight savings and strength. A SpeedMart Favorite.
#LRB TTUBE **\$169.99**



NEW!

DMI Lightweight Torque Tube

The truest torque tube we've found. Lightened everywhere where strength isn't compromised. Long collar provides stability for the increased traction of today's cars.
#DMI SRC-2393 **\$137.99**



Torque Tube Shims/Snout Repair Tool

Did a crash knock your car out of square? It's probably the snout of the rear. Once they bend, you must repair the snout. This tool will repair the snout without a machine. Then add a shim or 2 to take up the difference from what you cut off. Back in business!
Shims #LRB S30 **\$24.95**
Snout Facing Tool #LRB T0001P **\$149.95**



NEW!

DMI Oversized Tubular Driveshaft

Sprint cars are locked down so hard with today's wings that some teams are experiencing driveshaft whip. DMI has offered a solution for this in its oversized driveshaft. 2" OD material and completely true for ZERO driveshaft whip. Available in 26 1/2 and 27 1/2 for XR1 Swivel coupler. 29 1/4 and 30 1/4 for XR2 with swivel coupler. 28 3/4 and 29 3/4 for internal coupler rears. Material is chrome moly. OD is 2"
\$284.99



SpeedMart Complete Driveline Kit w/U-Joint

Everything you need from the back of the motor to the rear end at one low price! Complete with lightweight torque tube, tubular steel driveline, aluminum u-joint, aluminum torque ball, and housing.
#SMI K-DLC **\$649.99**
Steel Housing Substitution Add: **\$42.00**



Sanders Torque Tube

Sanders set the standard for driveline components years ago. Compatible with all torque ball and housings except MPD. In stock in 26.5", no cutting necessary.
#SAN 331-26.75 **\$199.99**

NEW!



Steel Hollow Driveshafts

By far the best driveshaft on the market! No vibration, even with the high horsepower 410's out today. Best value, too!
DMI #DMI SRC-2430 **\$108.99**
M&W #DS-30H **\$99.99**
Sanders #SAN-S164-16-26.5 **\$135.00**

Titanium Torque Tube Stud Kit

A complete kit of ti studs, AN washers and full nuts. Super light, and way easier than using bolts.
#AST 935-TT **\$44.99**



DMI Hollow Titanium Driveline

Larger O.D. than other brands to prevent vibration but oh so light! 6AL4V titanium.
#DMI SRC-2480 **\$785.99**

King Rear End Saver

NEW!

King's Rear End Saver is truly made to help protect your Rear End. This Rear End Saver is manufactured so that in a crash, you won't bend, break or pull the threads out of the snout of your expensive Rear End. Complete with all hardware.
#KRP 1630 **\$59.99**





DMI LW Torque Ball
DMI torque balls are hard coated first and then teflon coated for a smooth "no bind" feel.
#DMI SRC-2380 **\$99.99**



DMI Lightweight Torque Ball Housing
Perfectly machined then powdercoated with a durable non-corrosive finish.
#DMI SRC-2310 **\$147.99**



Winters Stamped Steel Torque Ball Housing & Ball
A little less expensive than the cast version, yet still protective steel to protect u-joint explosion from injuring the driver's feet. Complete with the rubber boot and anodized torque ball.
#WIN 4605 **\$212.99**



NEW!

Winters Cast Steel Torque Ball Housing & Ball

A complete set! And finally the ball and housing will stay clean! Complete with a cast steel protective housing, smooth anodized torque ball, and a rubber boot that slides over the joint to keep it free of mud.
#WIN 4609 **\$222.99**



NEW!



Billet Torque Ball Housing

King Racing Products has designed this housing with the racer in mind. Billet Aluminum for Maximum Safety while saving the weight of steel housings. Hard anodized for low friction and minimal wear. The only housing on the market that pivots in the same linear pattern as the U-Joint letting your car drive harder and roll freer. A SpeedMart Favorite.
#KRP 1605
\$189.99



NEW!



NEW!

Billet Aluminum Torque Ball

CAD 3 Designed for maximum strength and ultimate weight savings. Forged and then machined for a perfect low friction fit. Precision spherical Radius keeps your car rolling the corners free. Fits any 2.990 torque tube.
#KRP 1610 **\$129.99**

DMI Steel/Aluminum U-Joint

This is a great car owner's piece of mind. Adds only 17oz to the car over an aluminum U-Joint. Billet aluminum housing with steel snout protects the driver from the aluminum snout exploding in a wreck. Included in our Complete Driveline Kit as well.
#DMI SRC-2339 **\$216.99**



NEW!



NEW!

Sander U-Joint
Sanders U-Joints have been the standard for sprint car aluminum U-Joints for many years. Run exclusively by Steve Kinser Racing. Sold complete with Bolts and Spring.
#SAN S304A **\$259.99**



Winters Aluminum U-joint
7075 T6 forged aluminum u-joint. The strongest material used in u-joint construction.
#WIN 3700 **\$169.99**



MPD Torque Ball Housing
The original mag torque ball housing.
#MPD 068000-100 **\$176.99**

MPD Torque Ball LW
Machined from solid aluminum billet and are hard anodized.
#MPD 064203
\$146.99



MPD U-Joint (Plated)
Always replace an MPD U-joint with another MPD U-joint for correct driveline length!
#MPD 063800P
\$299.99



- > Improved pinion inspection location
- > Oil level plug
- > Lighter weight shifter housing assembly utilizing no hardware.



ALL NEW REARS COME COATED BLACK FOR FREE!

- > Non twist one bolt shifter cable mount.



- > High Temperature Silicone O-Ring provides a leak-free seal of the gear cover.
- > Cover Bridge Retainer keeps hot bearings where they belong.



- > Pinion support is increased by the re-designed casting. Incorporating a built in pinion reservoir, the XR-2 features increased oil capacity over a standard rear.

- > Center section nose bearing is 1 3/4" closer to rear axle to lessen the chances of a bent or broken snout in a wreck.

- > Available in swivel and standard 10/10 coupler.

DMI XR-2 Rear End

The Bulldog XR-2 is the rear for the 21st Century. The XR-2 saves 6 lbs. over the conventional rear while incorporating 95% of the same components. The XR-2 utilizes the DMI stock dependable ring and pinion. A mix of space age design and old fashioned common sense make the Bulldog XR-2 the premier rear for sprint car racing.

Complete XR-2 Rear End 4:12 Ring and Pinion (includes breather and shifter bracket)
#DMI RRC-9000 **\$1995.99**

SpeedMart Ultra-Light XR-2 Rear End \$ 2480.99
(Ours are coated)

EDM Ring Gear add: \$208.33
REM Ring and Pinion add: \$125.00

Titanium Bolt Kit add: \$500.00
Swivel Spline Coupler: \$375.00



Winters SpeedMart Pro Eliminator

Our standard rear end includes everything you need, nothing you don't. Xtra heavy duty center, shoulder splined axle, midweight axle (black or red), pinion nose roller bearing, heat treated lower shaft, and internal coupler. New Low Prices!

4:12 #WIN SM4:12 \$1599.99
4:86 #WIN SM4:86 \$1574.99

DMI Bulldog Rear End

Designed to withstand the most extreme abuse of any sprint car rear. Pinion bearing support uses a unique bat wing design for increased strength and more rigidity. Gear housing is supported by ribs top and bottom to eliminate breakage or failure. We stock them with the mid-weight and the lightweight axle and black thermal coating.

4:12 #RRC-5000 \$1899.99
4:86 #RRC-3000 \$1799.99



SpeedMart's Custom Ultralight Rear End

We built this one for the racer who wants to cut as much weight as he can without sacrificing longevity. EVERY part inside of this rear is lightened, titanium, or aluminum. The axle, however is a lightweight, not an ultralight. Most teams who run 360 and 410's don't want to have to change out their ultralight axle every 10 races like is recommended. The lightweight axle still saves 4 pounds over the standard axle. Ultralight axles are always available, and we carry one in stock, for those who run them.

4:12 #WIN SM412LW \$2725.99
4:86 #WIN SM486LW \$2680.99



Winters 8620 Quick Change Gears
Tons in stock.
Many ratios available!
#WIN 85XX **\$64.99**



SCS Quick Change Gears
The dominant quick change gear today. Regular gears will not hold up to your high horsepower. 1.5 lbs lighter than Winters Std gears.
See pg 133 for SCS gear chart.
#SCS XXX **\$158.99**



Winters Internal Coupler Seal
#WIN 7242 **\$13.99**

SCS Sportsman Gears
The SPORTSMAN SERIES gears are CNC Crown Hobbled to produce a quality that meets the exacting standards accepted by SCS. The gears are not lightened and are made of 8620 material. They are Heat Treated as are the PROFESSIONAL SERIES, but have a REM finish rather than the Black Oxide.
#SCS 11xx **\$74.99**



Winters Internal Coupler Conversion Kit
Fits Winters or DMI
#WIN 6942-01 **\$204.99**



Winters Breather Kit
A special O-ring fitting that will be tough to build for this price. Will work in DMI or Winters Rears.
#WIN 2966 **\$21.99**



DMI Spacer Kits & Individual Spacers
10 pc. alum spacer kit
#DMI SRC-2590A **\$69.99**
10 pc. mag spacer kit
#DMI SRC-2600A **\$249.99**



Aluminum Brake Clamp Spacer
Lines up inboard rotor and eliminates rotor warpage.
#WIN 2299 **\$19.99**



DMI Aluminum and Magnesium Axle Nuts
LH Thread (RR) RH Thread (LR)
Mag #DMI SRC-2660 **\$59.99** #DMI SRC-2650 **\$59.99**
Alum. #WIN 6121L **\$19.99** #WIN 6121R **\$19.99**

Winters Rear Cover
Winters Standard Aluminum Rear Cover will hold up to the heat and the abuse a sprint car will deliver. No need to upgrade!
#WIN 6746 **\$146.99**



Lightweight Side Bell w/ Caliper Mount
#WIN K6964-02 **\$282.99**



Inner Birdcage Steel Spacers
One protects the left side axle spline by covering it. One protects the right side from birdcage load.
Std. 3/16" #WIN 6156 **\$9.99**
U/L Birdcage Spline Protector
#WIN 2269 **\$14.99**



Winters Rear Cover Gasket
Std: #WIN 6729 **\$5.99**
Heavy Duty:
#WIN 6729HD **\$8.99**

Pro Eliminator Mag Center Section
#WIN K2225XHD **\$539.99**



King Hex Rear End Plug Kit



Great crew gift! No more bloody knuckles!
Grab a 1" box end ench to remove both rear plugs. You'll never go back to standard!
#KRP 2225 **\$32.99**

NEW!



Winters Ring and Pinion Sets
In stock complete with all of the goodies: pinion posi-lock and pinion nose roller bearing. Out of the box, into your quick change.
4:12 Complete
#WIN 5715LD **\$405.99**
4:86 Complete
#WIN 5401LD **\$361.99**





MPD Clamp on Positive Lock Shifter

Wow! No welding on frame! Still the same positive locking capabilities with no grinding or welding!
#MPD 084000C **\$161.99**



DMI 2 Bolt Shifter Bracket

Finally a shifter bracket that won't bend or rotate! Sold as a kit with spacers needed to space it away from the housing taking all bind out of the shifter cable.
#DMI RRC-1049 **\$31.99**

Winters LW 2 Bolt Shifter Bracket

This lightweight shifter bracket will save you a race. Unable to rotate, and made from lightweight steel so it won't bend from use. Bolts to 2 bolt holes on rear end for increased strength. Lines the shifter cable up perfectly.
#WIN 4043 **\$11.99**



MPD Positive Lock Shifter

MPD's lightweight shifter is a positive lock system that securely locks the car into gear. Lever is spring loaded, locking the rear end into or out of gear! The best shifter on the market!
#MPD 084000 **\$99.99**
Complete w/ Cable & Ends
#MPD 084000KT **\$157.70**



Quick Disconnect for Shifter Cable

10/32 x 1/4- Winters
#CAL QRSHIFT **\$7.99**

DMI Stratoshifter

ALL NEW DESIGN for the posi-lock shifter! This one might look similar, but it's got a way better final lock than the others. Even though the shifter handle is down, a guy would still like to know it is locked in gear. Takes the tension off the internals of the rear when the shifter is completely engaged every time.
#DMI SRC-2400 **\$139.99**
Comes with cable and all hardware.



Bracket for Shifter Cable

Very clean! Simple and light!
Stainless steel
#HRP 8001 **\$12.99**



SpeedMart Positive Lock Shifter

The only way to go to make sure your rear end does not come out of gear. Easy-to-grab handle that mounts directly to the frame rail on the right side of the car.
#MNW SHIFT **\$146.95**



Shifter Cables

Push/ pull w/ twist lock
#CAL SC38 **\$45.99**
MPD Shifter Cable
#MPD 084020 **\$44.99**
Posi Loc Shifter Cable
#CAL SC40 **\$45.99**

Winters Posi Lock Shifter

Used by all of the professionals. Anodized black and sold complete with cable and all ends.
#WIN 3232 **\$109.99**



NEW!

Sander Magnesium Direct Mount Front Hubs

Aircraft Magnesium CNC Machined heat treated and CNC Machined to exact tolerances make these the sprint car standard in front hubs. Hubs have watertight dust caps for oil filling capabilities.

#SAN 1015 Set



10.93 LBS

\$451.99

LOWEST PRICE ON THE MARKET!



11.72 LBS

Winters Ultralight Front Hubs

Complete Set!

Winters has built a brilliant gold front hub using the strongest material possible for added strength. The most common front hub on the market today. Screw on caps with o-rings for oil filling capabilities. Fits all direct mount front wheels.

#WIN 3980 **ONLY \$214.99**



Front End Bearings and Seals

We offer replacements for both bearing and seal sizes.

Bearings (Stepped or Straight Snout)

\$12.99

Seals (Stepped or Straight Snout)

\$8.95

Races (Stepped or Straight Snout)

\$6.95

Black Widow Front Hubs

Fully contained roller bearing design or standard bearings available. Super light but extremely strong.

Spacing in lightning pockets designed after two years of testing to maximize strength without additional weight gain. These are the nicest hubs made today!

#DMI SRC-1971 **\$299.99**



11.75 LBS



Weld Ultra Hub

Weld has cornered the market with their new 3 spoke front hub. Track tested on winged and non wing sprint cars on the toughest race tracks in the country! These ultra-light hubs will take a beating!

Sprint LF C88-LT3

Sprint RF C88-RT3

\$248.99 ea.



8.3 LBS



PICK YOUR FRONT END KIT HERE

Complete DMI Black Widow Front End

DMI Black Widow Hubs
Winters Spindles, Kingpins, Steering Arms, Brake Rotor, Brake Mount
Rocket 2 1/4" Front Axle
MPD Thrust Kit
Polished Tie Rod
QA1 Heims
Grade 8 Bolts with 1/2 nuts
Aluminum Heim Spacers
#SMI K-FEBW **\$839.99**

Super Strong, Light, Front Hubs



Complete Winters Direct Mount Front End

Contents:
Winters Front Hubs
Winters Spindles, Kingpins, Steering Arms, Brake Rotor, Brake Mount
Rocket Chassis 2 1/4" Front Axle
MPD Thrust Kit
Polished Tie Rod
QA1 Heims
Grade 8 Bolts with 1/2 nuts
Aluminum Heim Spacers
#SMI K-FEW **\$749.99**

BEST VALUE!!



UPGRADE YOUR FRONT END KIT HERE

UPGRADE & REPLACE ANY OF THE FOLLOWING ITEMS WITH THE ITEMS INCLUDED IN YOUR KIT



Complete Titanium Upgrade (AVAILABLE ON ALL FRONT ENDS!)

Contains:
DMI Titanium Spindles
DMI Titanium Kingpins
All bolts titanium including: front rotor, RF steering arm, LF steering arm bolts, and tie rod bolts.
#SMI FAOPTI **\$499.99**



Steel Rotor Upgrade

Contains:
Brakeman 10 7/8" Steel Rotor
DMI 11" Brake Mount
#SMI K-FAOPST **\$68.00**



Substitution of 11" Rotor available.
#SMI K-FAOP11



2 1/2" Front Axle Upgrade

Upgrade to a lightweight 2 1/2" front axle. Saves 2 lbs.
#K-FAOPAX **\$34.99**



FRONT END



Rocket 2 1/4" "Tipped" Front Axle

Wait 'til you try one of these axles! We sell over 500 a year all over the country. 12°/3° on right front 9° on the left.

#ROC FA22550 \$179.95



2 1/2" Lightweight Front Axle

Chrome Powder Coated 2 1/2" Lightweight Front Axle with castor and camber built in. Precision built and pre-reamed kingpin eyes.

#MNW FA250-50P \$219.00



Rocket Non-wing Front Axle

Available in 52", 53", and 54". Super strong. Run by the nation's top non wing drivers. Our 52" version is used in many winged cars also.

52" #ROC FA 22552 \$179.95

53" #ROC FA 22553 \$179.95

53" #ROC FA 22554 \$179.95

Deluxe Spindle Nut Kit

"Trick" Spindle lock nut kit allows for finer adjustments.

DMI: #DMI SRC-1997 \$19.99

MPD: #MPD 01420KLT \$45.99



DMI Spindles

Available with steel or ti, step or straight snout. All snouts are Rockwell tested for hardness. All spindles are made lightweight durable forged aluminum, with your choice of steel or titanium.

Straight Snout: #DMI SRC-2000 \$147.99

Step Snout: #DMI SRC-2010 \$189.99

Straight Ti Snout: #DMI SRC-2020 \$229.99



XXX Race Company 2 1/4 and Lightweight Front Axles

4130 Chrome Moly (tube) Front Axle. Plated. Available in Black Powder Coat, Chrome and White Powder Coat.

#TRX SC-FA0002 \$125.00 Plated

#TRX SC-FA0007 \$125.00 White

#TRX SC-FA0008 \$125.00 Black



13 LBS

NEW!



J & J Lightweight Front Axle

Built with superior quality from the folks at J & J. Precision welded with extended shock studs, nuts and spacers all included. Kingpins fit perfectly with NO deflection. Accept no substitutes!

#JNJ 103001 \$219.99

Sander Aluminum Spindle

New redesigned version is lighter than years past yet still made from the best material for superior strength. Made from 2024 t351 Aircraft Material. Complete with nut and clevis pin.

#SAN S503 \$240.99

NEW!



Winters Lightweight Spindle

Made from high quality aluminum and machined with precise tolerances. Designed to be the strongest spindle made. Fully adjustable locknut comes stock.

#WIN 3622 \$128.99





Titanium Front Axle to Radius Rod Bolt

The perfect length to fit through the axle bracket for the radius rod. Custom cut shank to keep the threads intact as suspension works. Sold in kits of 3.

#AST 5814KIT \$43.99

Titanium Front Rotor Bolts

Beveled perfectly to mount any sprint car front rotor to all front hubs.

#AST 3507KIT \$33.99



Left Front Steering Arm Bolts

Tapered head countersunk bolts sized perfectly for the left front steering arm of a sprint car. Tighten them down with an allen and go!

#AST 3519KIT \$28.99



Titanium Inboard Brake Caliper Bolts

Sold in sets of 2. Bolts caliper directly to rear end. Very strong!

#AST 4715KIT \$22.99



Steel Tubular King Pins

Available in the long version also.

Steel #WIN 6476-2WC \$20.99

Titanium King Pins

Saves over 1/2 lb from steel and the best longevity you can buy in a kingpin. Same length as a stock steel and utilizes the same cap as the DMI steel kingpin.

#DMI SRC-2059 \$81.99



Titanium Right Front Steering Arm Bolts

Mounts the right front steering arm through the spindle on any brand spindle.

#AST 5817KIT \$35.99



Replacement King Pin Caps

We carry them for long and short kingpins.

Short #DMI SRC-2045

Long #DMI SRC-2055

\$4.99



J & J and Sander Steering Arms

Built with strength in mind yet Very Light. Fits 3 1/4" spindles with a 1" offset on the Tie Rod and a 6" offset on the drag link for superior steering feel.

J & J #JNJ 103009C \$79.99

SAN #SAN S506-CR6 \$91.99

DMI Combo Arm

Made for 3 1/4" spindles. Standard offset of 5.5" x 1" forward. Best steering arm for turning radius.

#DMI SRC-2085 \$61.99



DMI Right Hand Steering Arm

Made for 3 1/4" spindles. Super strong and light, too.

#DMI SRC-2100 \$35.99



MPD King Pin Bushing Kit

#MPD 014203 \$17.99

Gen 2 Steering Gear

KSE stepped up to the demands of today's racer with the Gen 2 steering gear. Complete with built in reservoir, this gear is 25% lighter than its predecessor, and eliminates the need for any extra fittings and hoses saving even more weight. A single -10 line from the built-in reservoir to the pump inlet, and a -6 pressure line from the pump to the pressure port is all that is needed. The

new four-degree valve and 20% faster lead ball screw transfers quicker front wheel feedback to the hydraulic assist to improve front wheel stability. This all new valve contours the pressure load over a greater range than the previous two degree valve. This provides a more uniform feel in the steering wheel regardless of the steering load on the front wheels.

- Built in Reservoir
- Wing Slider Ports
- Positive Feel
- Consistent Feel
- Improved Durability
- Less Weight
- Simplifies Plumbing
- Easier and Cleaner Installation
- No "Tight" Spots

#KSE GEN 25652 **\$1449.99**



King 1/2 Box Mount

The nicest 1/2 box mount out on the market. Lightened just the right amount and anodized black. #KRP 1420 **\$34.99**

NEW!



NEW!



King Lightweight Steering Gear Mount

Wow! This is cool. Anodized Black and lightened everywhere it can be. Available in Left Side, Right Side and Bottom location for fuel shutoff. #KRP 1435 **\$24.99**



Baffled Power Steering Reservoir

Tapers down at the bottom for clearance for steering gear. Baffle inside helps stabilize power steering fluid. **Wide #SAL BPSR-10 \$79.99**

KSE Gen 2 Steering Gear Wing Slider Fitting

Required to plumb a wing slider assembly into a Gen 2 Steering Gear. Fitting not available aftermarket. #KSE KSM6002 **\$5.99**



LRB Lightweight Power Steering Mount

The lightest power steering pump mount on the market today. Fits standard and raised cam engine blocks for easy application. Black anodized and lightened in every way possible. #LRB PSPMT **\$49.99**



KSE Pump

KSE HPD pump has the most efficiency, lightest weight, and smallest package of any pump in the industry. Weighing in at 2.5 lbs including mounting bracket and fits in all makes of sprint car and midget chassis. The special design tear-drop timed porting and large #10 inlet eliminates cavitation up to 10,000 engine RPM. Stock with 3000 PSI pressure capability with non-sticking poppet-type relief valve set at 1400 PSI. This is made possible by the rigid construction design and zero tolerance clearances as well as thermal expansion of only 0.0001 @ 200 degrees. #KSE 1068-002 **\$529.99**



The Ultimate Steering Wheel

The coolest steering wheel we've ever seen stock! 15" Diameter with CNC holes in all possible locations. 1 1/8" Grip for reduced hand fatigue. Very light but very strong. Precision built. Silver or Black available.
 #JOE 13535-A \$79.99 (Silver)
 #JOE 13535-B \$82.99 (Black Anodized)



NEW!

JOES Steering Wheel Tape

Stops your hands from slipping on the wheel and keeps gloves from ripping.
 #JOE13600 \$6.99



Butlerbuilt Aluminum Steering Wheel

The 1 1/4" version is the widest grip steering wheel on the market. Available on 1" or 1 1/4" tube for reduced hand fatigue. 15" or 17".
 #BUT 1X-X \$82.99
 Powder Coated Black or Red Available



KSE Steering Hub

Sold with new gears, but they get lost or robbed off of used gears. Only fits KSE.
 #KSE KSG1027 \$109.99



LRB Pitman Arm

Made from 2024 aluminum. We have increased the strength on the splined end. Arms are lightweight but strong. Offered in 10 Degree Broach and Straight Broach. Drag Link Holes at 10 and 11".
 St. #LRB PA1 \$59.99
 Angle #LRB PA1A \$59.99



Weld on Splined or Hex Steering Gear Hubs

Welds onto 3/4" steering shaft. Both hubs are aluminum with either push button or spline pull type quick release.
 Hex: #LON 56600 \$29.95
 Spline (pull): #LON 56605 \$64.99



SpeedMart Top Steering Mount

Standard steering mount for all late model cars and steering gears.
 #KMI 011945 \$15.95

Top Steering Plate for MPD or Waterman Shutoff

Mount your fuel shutoff where you can easily reach it! Much safer in a fire, & easy to plumb to pump.

MPD Shutoff #KMI TSPMPD \$27.95
 Waterman Shutoff #KMI TSWAT \$21.95



Ultralight Hi Pressure Power Steering Hose

3/4 of a pound lighter than a standard high pressure hose! We've got the steering gear plumbing perfect for the KSE pumps and gears. This hose fits awesome!
 #BMR RC-015 \$69.95



Hi Pressure Power Steering Hose

With the high pressure pumps used in sprint cars today, it is impossible to use STD hose and fittings for your pressure line from the gear to the pump. Save yourself a race. Replace these lines often!
 When ordering specify gear & pump
 #SKA GEN2 \$26.95
 #SKA HO9090 \$26.95
 #SKA HO90ST \$27.99



Lightened 10 Degree Pitman Arm

Made from billet aluminum, this angle swedged pitman arm will help the muffler clearance problem.
 #MNW PA12A \$43.99

Vortex Top Wings

Simply the best top wing on the market today. Undisputed. Vortex wings have over 360 wins, 4 Outlaw Championships and 5 Knoxville Championships. Run exclusively by Shatz Racing, Terry McCarl and the SpeedMart Sprinter of Martinez Racing. LR Drive is increased immediately by switching to Vortex. Wing is well worth every dollar you spend in how the race car performs. Sold in 2 1/2" dish and flat with 1" Wicker. Panel kick out options available. Sold with panels off. Wing assembly available.

Outlaw Flat #VOR OLPFT **\$849.99**
Standard Weight Dish #VOR TWSTD **\$695.00**



Photo by Stacy Verrall

NEW!

H2H

HRP LW Top Wing

The only wing made with recessed rivets! This is not your common sportsman wing that the others sell. The panels are completely flat when you run your hand across them. The perfect wing to apply vinyl wraps to. CNC punched, aerodynamic

tested, strong, and lightweight. Run by all of the top teams.

Unassembled: #HRP 8521 **\$695.00**
Assembled: #HRP 8521C **\$725.00**

NEW!**Top Wing Roller Posts**

Made to fit the HRP wings. Teflon rollers allow wing to glide easily as the driver adjusts it with the wing valve. Zero friction! Wing moves much faster!

#TRX SC-TW-0016 **\$29.00**

HRP Top Wing Internal Posts

All new design! No tube to crush, and very smooth radius to not allow the wing to gall on the underside where they ride.
#HRP TWPOST **\$26.95**

**XXX Wing Tee Insert**

#TRX SC-TW-0012 **\$10.50**

XXX Aero Wing Tee

Designed to fit all wings. Ultralight, yet designed for strength!

#TRX SC-TW-0011 **\$78.98**

**Aerotech Wing Caps**

Designed by Racers for Racers.

These are more durable than carbon fiber at 1/2 the price. High density plastic makes 'em super strong! UPS Shipable!

Top only #ARO TOPBL **\$60.00**

Top and Nose Wing Set #ARO WC SET **\$95.00**

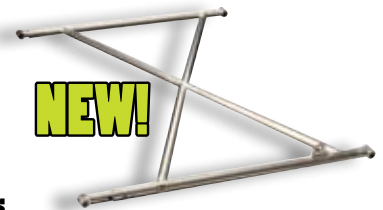
**NEW!****XXX Top Wing Internal Runner Posts**

Top wing posts. Plated 4130. Built strong so they don't bend like some we've used from other suppliers.

IMPORTANT NOTE: The "T" on the top of the post is 5/16" in diameter. Please ensure this will fit your wing runners.

#TRX SC-TW-0004 **\$12.50**

NEW!**T22 Titanium Top Wing Post**

Ti22's Wing Posts are 11 5/8" in length with a 1" OD and are available in Titanium or Chromoly. Weight: Titanium - 7.5 oz., Chromoly - 13.9 oz.

#T22 1010T **\$74.99**

**XXX Race Company Plated Tubular Wing Tee**

Top wing tree. Plated 4130 Chrome Moly. 1" adjustment holes, with a total of 6" of adjustment. "X" design for lateral and horizontal strength.

Comes with two 1/8" aluminum spacers (to fit various wider chassis mounts).

#TRX SC-TW-0002

\$64.00



Vortex Nose Wing

Vortex Nose Wings are built with the concept of air management. The cleaner the air under the nose wing, the more downforce it creates and the more clean, cool air is taken in by the engine. Tons of wind tunnel tests have proved the theories of air management/horsepower correlation. Make no mistake, these guys do nothing 1/2 way.

#VOR SFW-1 \$125.00



HRP Nose Wings

The strongest nose wing in sprint car racing! No supports needed from the wing body to the panels because they're properly constructed. We stock them in 2" Deep Dish with both angled and straight panels. (Hint: angle panels allow you to push the car farther into the trailer.)

Tall board #NW1SB \$125.00

Super board #NW2SB \$125.00

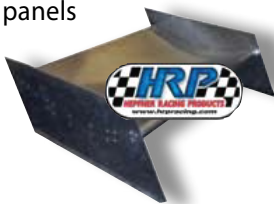

NEW!

HRP Adjustable Nose Wing Posts

The best value in adjustable nose wing posts on the market! Aluminum angled bases with aerodynamic posts chrome plated for a shiny light and strong. Super light and strong.

#HRP NWPS \$102.99



1/4" Quick Pins

Great for wings for easy removal.

#CHA 240-801 \$1.75 ea.



XXX Outboard Nose Wing Rear Straps

Tubular rear wing straps to attach from car to panels of nose wing. Built from 4130 material. 10 3/4" hole to hole.

#TRX SC-TW-0029 \$25.99



NEW!

MNW Nose Wing Straps

Ultra Light Aircraft Aluminum Perfect balance of weight to strength.

#MNW NWS12 \$12.95



NEW!

R Clips for Shocks or Wing T's (or Whatever!)

You might even need some in the trailer!

#CHA A-RCLIP-5pk \$5.25



HRP Stainless Bent Forward Front Wing Post

Built from Lightweight Stainless and bent forward but LEGAL with and Outlaw front wing jig. Super light, yet strong. Easier to remove after a wreck also when crashed unlike aluminum posts.

#HRP 8058 \$18.99



NEW!

Bent Aluminum Nose Wing Posts

These posts move your wing forward for more down force on the front end, making the car more drivable.

#MNW FWP-200 \$12.95

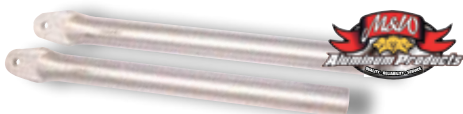

Vortex Aero Style Nose Wing Rear Strap

Built from 4130 Chromeoly and Welded for added strength with 3 adjustment holes at 10 3/4", 11 1/2" and 12 1/4".

#VOR xHFWPST (specify side) \$22.99



Straight Aluminum Nose Wing Posts

Shiny & light yet super strong.

#MNW FWP 100 \$10.95

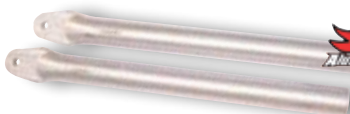

Offset Rear Nose Wing Strap

Designed to clean up the air under the nose wing allowing it all to go to engine and top wing for down force. Mounts to standard wing spuds on car and nose wing panels on wing. Light, yet super strong! Extra Heavy Duty for when strength is more important than L.W weight.

#HRP NW8114 \$26.95 ea.

Everything you need to connect your Gen 2 steering gear to your top wing.

Lightweight Kit for Gen 2 Steering Gears

Wing cylinder (1) QA1 Wing Heim (1)
 MPD lightweight wing valve (1) MPD Cylinder Wiper (1)
 #3 ORB to #4 JIC St. (2) XRP -4 x 1/8" NPT 90 (2)
 Kevlar 18" Wing Line (2) XRP -4 x 1/8" NPT 45 (4)
 Kevlar 22" Wing Line (1) #SMI K-WSG2 **\$359.95**
 Kevlar 34" Wing Line (1)

NEW!

DMI Hot Wing Valve

Need a techno-looking part in your sprint car? We've got one for you. All the same guts as the old style valves but with a really cool billet handle.

Easy to grab too!

DMI SRC-2920 **\$149.99**



SM Wing Cylinder

The perfect length for all late model chassis, no matter what brand. We've kept the price down, too!

#SMI WI-WSC **\$48.99**



Titanium Wing Valve Bolts

Bolts the wing valve to the chassis.

#AST 4405KIT **\$9.99**



MPD Lightweight Wing Valve

One of the coolest looking parts on a sprint car. Used in 80% of sprint cars worldwide. Very reliable and extremely light.

#MPD 036000LT **\$139.99**



Wing Cylinder Wiper Seal

Stop leaky wing cylinders cheaply!

#MPD 03580W **\$9.99**



Wing Slider Diagram

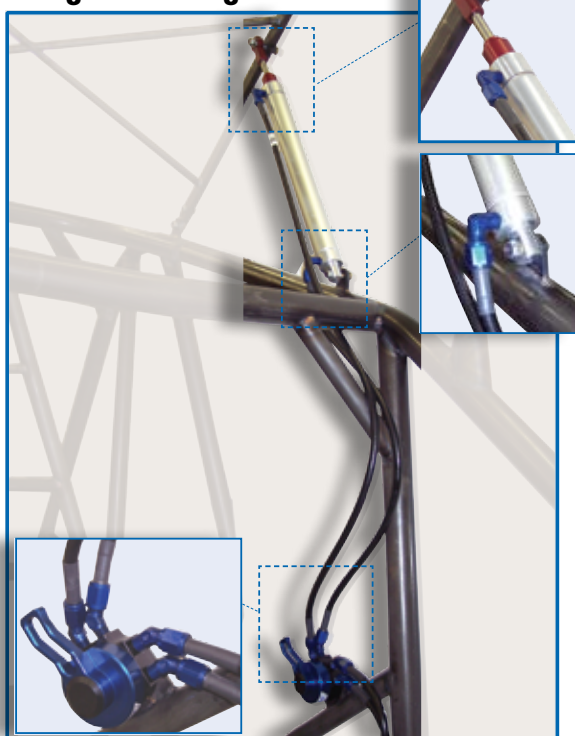

Teflon Lined Stainless Steel Braided Wing Lines

We carry flex lines from 5" to 28" with either straight fittings on both ends or a 90 deg fitting on one end. Also available in -4 for oil pressure gauge & wings.

#BKL 4-xx **\$15.00**

w/ 90° fitting on one end: **\$19.99**

See pg 65 for complete size & price list for braided line



Adjustable Manual Wing Slider

#HRP 8559 **\$67.95**



Wing Cylinder Heim

3/8" on the screw on end to fit the wing cylinder and 5/16" to fit the aero wing tees perfectly.

#QA1 AFR5-6 **\$10.00**



Kevlar Hi Strength Wing Lines

You've seen these in the outlaw cars. Black -4 hi strength coated lines for your wing cylinder. Super easy to use. Made to fit Rocket, Eagle, Maxim, or XXX cars perfectly.

Front: #GDR 422BK **\$28.99**

Rear: #GDR 434BK **\$34.99**

TIRE TECH

The following text is intended as merely a guideline based on the experiences over the years. We acknowledge there will be other opinions that may be as successful or possibly even more successful than those set forth below. There is no one "right" method. As racers, you may want to use the information as a starting point and modify your technique based on your own experience and success at the track you are racing.

SIPING

SIPING ONLY: When applying this technique to a dirt sprint tire, siping will do many things. First, this will help the tire build heat quicker which will help the tire "fire" better. Siping will also dissipate heat when the tire gets to operating temperature and the sipes open up. If you are using a fairly hard tire, siping will help create a "graining" effect which will help keep the tire from "sealing" over. The only sprint compound not normally recommended siping is a D10 tire because it is already very soft and may result in "tearing" of the tread blocks and will result in loss of traction. As such, you rarely see Hoosier sprint tires siped for qualifying since the D10 compound is normally the qualifying compound. Also, never sipe a tire more than half the depth of the tread block. Any deeper than half the depth of the tread block may cause the sipes to rip or chunk out. How much you sipe a tire will come from your own experience through trial and error. Also, like all good racers, pay attention to what techniques your competitors are using. They may have learned something you have yet to experience.

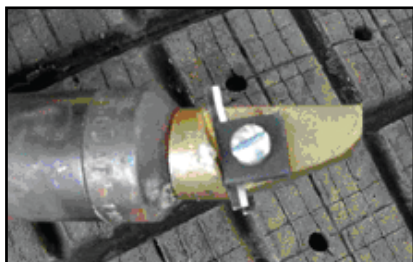

Generally, the grooving blade is reversed to result in two independent cutting blades. The depth should be set no deeper than 1/2 the depth of the tread blocks. Deeper than 1/2 the depth may cause individual tread blocks to rip or chunk out. When setting the depth of the blades for siping, place the siping head on the tread block and visually adjust the depth to 1/2 the thickness of the block.

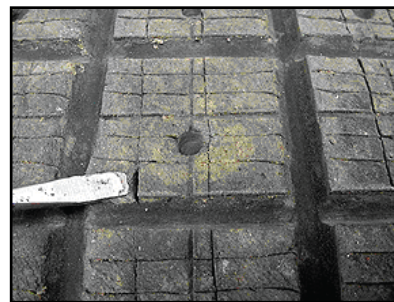

A sipe is simply a razor thin cut or slit in the rubber tread block.



Proper siping of this tire has resulted in a very nice texture or grain to the tread surface. The siping allowed the tire to "fire" quickly on starts or re-starts and as the race went on, the sipes allowed heat to be expelled which resulted in less chance of blistering.

GROOVING

GROOVING ONLY: We recommend grooving a tire if the track is very wet and heavy or if the track is a hard surface with a lot of loose dirt blowing across the surface. Grooving will help channel the dirt out the tire to help maintain a good contact patch between the tire and track surface--just like the grooves in your street tire which help keep your car from hydroplaning. Grooving will also create more edges for better traction or grip. Just as with siping, how much you elect to groove your tires depends on what you have experienced in the past along with watching what the top finishing drivers are doing as well.



Straight grooves work best for forward bite. We recommend no wider than 3/16" wide of grooves. Wider than this may tend to cause the tread block to rip or peel back.

When using a very hard compound, you may want to 1/4 groove the tread blocks allowing for a greater degree of "cleaning" grooves and more edges for increased traction. Usually the tire is cut vertically and then horizontally or vice versa.



GROOVING Continued

Grooves can also be cut at angles. Angled grooves will result in a combination of increased side bite as well as increased forward bite.

Unlike siping in which you should go no deeper than 1/2 the depth of the tread block, grooving can and generally is the full depth of the tread block. Also, the "hole" in the tread block(s) is called a "heat dispersion vent" which serves to reduce the chances of blistering.



SIPING AND GROOVING: Combining both siping and grooving is normally done in both heat and feature races. You may need the grooves for cleaning but yet you also need to do some siping to help the tire "fire" and to allow the tread surface to properly "grain".

Proper grooving and siping techniques will ultimately result in a better performing sprint tire which will in turn result in higher finishes.

Recommended operating temperatures of Hoosier sprint tires under various track conditions?

Optimum temperature ranges for Hoosier Sprint tires:

The following is a table with temperature limitations for Hoosier Sprint tires. Please keep in mind that there are a number of variables that must be taken into account when taking tire temperatures. Some of these variables are:

1. Needle pyrometer vs. surface pyrometer vs. infrared pyrometer. The temperatures listed are from a needle pyrometer. Surface pyrometer readings will be 10 to 20% lower than needle readings. Infrared pyrometer readings should be close to surface pyrometer readings provided that the distance from the pyrometer to the tire is in the range designed for the pyrometer being used. This distance is typically about 6-8".
2. The time between being at full speed on the track and taking the reading. This variable is very hard to factor out. If tire temps are high and the ambient temperatures are low the tire will cool very fast and your temperature readings will be misleading.
3. Location on the tire. This includes which row of blocks on the tire and where in the block you are checking. It is best to always check the same rows. It is also best to stay at least 3/8" away from a groove or heat dissipation vent. Temperatures on the first inside row and the outer 2 rows of a 105/18 should be excluded. On left rears, the 1st inside and 1st outside rows should be excluded.
4. The amount of wear the tire sees: As tread rubber wears down there is less mass to heat up so tire temps will be lower.
5. Pyrometer calibration.

These are temperature readings taken within 3 to 4 minutes after the car is at full speed on full tread depth non-grooved tires. If tire temps are below the minimum listed the tire will be slow to fire. If tire temps are above the maximum listed the tire will slow down due to fatigue or blistering. The average temperature of the tire should be within the ranges listed below. If one row on the tire is running hotter than the listed ranges try grooving that row in a circumferential direction.

D10 ambient

temp up to 200°F

RD12 ambient temp up to 220°F

D12 160°F up to 250°F

RD15 160°F up to 230°F

D15 160°F up to 260°F

D20 180°F up to 260°F (unless it is a high wear situation)

F55 200°F up to 280°F

A good balance between left rear and right rear tires is also important. A good rule of thumb is that the left rear should be around 20-30°F cooler than the right rear. One exception is a high speed, high banked track like Eldora. At Eldora we typically see LR temps about equal to RR temps.

A common pitfall is that if the tires are running too hot it is not always the best thing to run a harder tire. A harder tire provides less traction (except F55) and will spin more which in turn will make it run hotter. Sometimes a softer tire will hook the car up better or grain a little. Both of these conditions will make the tire run cooler. With "RD" type tires being high traction tires for dry slick tracks and "D" type tires being for high heat, high speed tracks these are a few of the most common combinations:

"D" LR and "D" RR (Eldora-type tracks)

"RD" LR and "D" RR (Lincoln Speedway or Williams Grove Speedway when the track is fast)

"RD" LR and "RD" RR (Lincoln Speedway or Williams Grove Speedway when the track is slow)

SQUARING CAR - SPRINT

Squaring the Rear Axle:

- There are many different ways to square the rear end depending upon mechanical preference and comfort. This is one popular technique utilized by many professional teams.
- Place the rear end in the chassis and bolt up the torque tube. Set the axles on 6" blocks if it's a standard chassis, 5" on the left side and 6" on the right if it's a raised rail car.
- Secure the birdcages with spacers and the wheel nuts. Measure the distance from the rear round machined portion of the torque tube to the outer edge of the chassis by placing a straight edge vertically against the frame.
- Center the rear end by equalizing this distance on both sides of the car.
- This distance should measure between 10 1/8" and 10 1/4". Now with the rear centered side-to-side, start with the right side and measure from the leading edge of the rear axle to the front edge of the motor plate.
- On a 39" car this measurement is 37 5/8", 38 5/8" on a 40" car. Roll the axle forward or back on the blocks to achieve the correct distance.
- Once you have secured that distance on the right side check the left side. Ensuring that the rear is still centered in the frame and the right side measures correct, the left side may vary by as much as 1/8". This is generally left to lie as is.
- With the radius rods connected, place a level on the flat bottom portion of each bird cage and adjust the rods so that each cage is level with the bottom frame rail.
- Now bring your rear arms up to each bird cage flag and adjust each rod end so that the lower bird cage bolts slide freely through the cage and the rod end. Having completed this, recheck all of your measurements to ensure that nothing was moved during the previous processes.
- If all measures correct bring your jacob's ladder to the rod end or clevis and adjust the rod end or clevis in or out so that the bolt also slides freely. With these operations complete check your work by ensuring the torque ball is free and the jacob's ladder is not bound.
- Now you are ready for race height setup blocks and stops.

Squaring the Front Axle:

- Set the front axle on 4" set-up blocks, or 3" and 4" if it is a raised rail car. Offset the axle 1" to the left side by adjusting the sway bar. This gives clearance to the left front torsion arm and combo steering arm.
- Measure 13 5/8" from the center of the right front torsion tube to the center of the axle on both sides.
- After roughing in the radius rods to this measurement, measure from the leading edge of the rear axle (still on 6" blocks) to the rear edge of the front axle on the right side.
- After having gained this measurement we will set the lead.
- Check the left side the same way and adjust the rod length so that the left measurement is equal to or up to 1/4" set back depending upon driver preference and size of track.
- With the axle now square we can adjust the caster. Place an angle finder on the right front steering arm.
- Adjust the top right front radius rod so that the angle reads anywhere from 6 to 10 degrees. Again this is driver preference, some drivers like more positive feel in the front end than others.
- With this complete you can drop the axle down to race height set-up blocks and adjust the stops. Don't forget to set the tow. An 1/8" of tow out is generally the norm.



Chassis Adjustment Quick Reference**Loose at corner Entry**

- 1) Reduce right rear air pressure
- 2) Move right rear wheel in
- 3) Use narrower right rear wheel or more offset
- 4) Raise chassis ride height front and rear
- 5) Take out tilt (raise left side)
- 6) Add right rear cross weight
- 7) Use less bar split
- 8) Use softer right rear bar
- 9) Drive car in straighter

Loose At Mid-Corner

- 1) Reduce stagger
- 2) Raise ride height front and rear
- 3) Use softer rebound shock valving at left front and left rear
- 4) Use higher gear
- 5) Take tilt out (raise left side)
- 6) Raise forward end of left rear radius rod
- 7) Move wing back or use more wing angle

Loose At Corner Exit

- 1) Reduce stagger
- 2) Raise front ride height
- 3) Use higher gear
- 4) Move wing back or use more wing angle
- 5) Use softer rebound shock valving at right front
- 6) Increase left rear cross weight
- 7) Use softer right front spring rate
- 8) Use softer spring rate at right front and right rear
- 9) Roll into the throttle smoother

Loose At All Three Phases Of Corner

- 1) Raise ride height front and rear
- 2) Take out tilt (raise left side)
- 3) Reduce stagger
- 4) Move wing back
- 5) Use softer spring rate at right front and right rear

Tight At Corner Entry

- 1) Increase right rear air pressure
- 2) Move right rear wheel out
- 3) Use more wheel offset at right rear
- 4) Use wider right rear wheel
- 5) Add tilt (lower left side)
- 6) Use more bar split front and rear
- 7) Use stiffer right rear torsion bar
- 8) Use softer left rear and left front torsion bars
- 9) Use stiffer shock rebound valving at left rear
- 11) Driver can shake car loose and stab throttle

Tight At Mid Corner

- 1) Increase stagger
- 2) Use lower gear
- 3) Lower chassis ride height
- 4) Use more tilt (lower left side)
- 5) Lower left rear radius rod forward end
- 6) Move wing forward
- 7) Use stiffer shock rebound valving left front

Tight At Corner Exit

- 1) Increase stagger
- 2) Lower the front ride height
- 3) Use lower gear
- 4) Move wing forward
- 5) Increase nose wing angle
- 6) Use stiffer shock rebound valving on both front shocks

Tight At All Three Phases Of Corner

- 1) Increase right rear air pressure
- 2) Increase stagger
- 3) Move wing forward
- 4) Use softer left front torsion bar
- 5) Move right rear wheel out

Adjusting The Chassis With Tilt

Affects of taking tilt out of chassis:

- 1) Moves center of weight mass to the right. So more weight transfers to right side of car. Affects the car through first half of cornering.
- 2) Raising left side of car up creates positive arm angle at left front. This makes the car tighter at corner entry by holding weight at the left front and right rear corners.
- 3) Raising the left side of the car up raises the height of the left side radius rod mounting point on the chassis at the left rear. Under acceleration this creates more thrust loading on the left rear tire.
- 4) Increases the positive arm angle on the left rear and adds bar preload, so at corner exit the bar unloads harder on the left rear.

Affects of adding tilt to the chassis:

- 1) Moves weight mass to the left, which loosens up chassis at corner entry.
- 2) Increases torsion arm angle at left front so car turns in easier.
- 3) Lowers the height of the radius rod mounting point on the chassis at the left rear.
- 4) Takes out positive arm angle at the left rear so car won't drive as hard at corner exit.

PNIP 600CC MICRO-SPRINT SETUP SHEET

Materials

- Level car stands
- 12'-25' Steel Tape Measure
- Combination Square
- 2" and 4" wood blocks or adjustable Moose Blocks
- Stagger Tape
- 3' of 7/16" steel rod
- Torpedo Level or Angle Finder

Squaring the Rear Axle

- Start by setting the left rear arm at 12 1/2" measured from the center of the splines to center of the rod end. Then hook up the rear arms to the torsion bars and slide the 7/16" steel rod through the rod ends. Set the rod on 2" blocks then measure the distance from the rod to the front of the rear torsion tubes, it should measure approx. 10-3/16" to 10-1/4". Now you should adjust the right rear arm accordingly to square the rear arms to the rear torsion tubes.
- The next step is to install the rear axle assembly in the car. Be sure to have spacers in place of the wheels on the axle to lock down all axle components. Set axle on 4" square up blocks and by using the flat face on the front of the birdcages level the birdcages by adjusting the radius rods on each side. Now measure from the back edge of the axle to the back edge of the rear torsion tube using a combination square. It should measure approx. 12-3/16" to 12-1/4", the measurement will be 1/16" longer on the right side with the short splined axle and cars with the universal splined axles will be even.

Rear Radius Rods

- Start with the left rear rod in the bottom position just above the brake rod stud.
- Start with the right rear rod in the top position.

W-Link (Jacobs Ladder)

- Mount the bottom in the outside hole.
- Mount the top in the inside hole.
- With the rod ends on the torsion arms centered in the birdcage bracket, adjust the rod end on the birdcage to hook up the ladder.

Setup Blocks

- Use 2" blocks for both the front and rear, you may vary different heights for heavier/lighter drivers and also tracksize the conditions.
- Coil front-Add 2 turns into left front coil.
- Torsion front-Add 1 turn into left front bar.
- Split Torsion Bar Cars-Add 1 1/2 Turns to left front
- Both cars add 1 1/2 turns into left rear torsion bar when using 50 points of bar split, 25 points of bar split 1 turn, even bars 1/2 turn, and 0 turns when running reverse bar split.

Squaring the Front Axle

- Set car up on the 2" blocks and measure from the front edge of front upright tubes to the back of the front axle at 6" to 6-1/8" (5" to 5-1/8" on '06 and older chassis) on both sides. This will set your wheel base to approx. 60-1/2" (59-1/2" on '06 and older).



PNIP 600CC MICRO-SPRINT SETUP SHEET

Caster

- Adjust the right front rods to set caster. Caster should be a minimum of 8° measured from the top of steering arm on the right side. As much as 12° of caster may be used. More caster allows the car to track straighter and will help excessive over steer.

Lead

- Adjust lead after car is set on the ground, run 0 to ¼" lead. Lead will allow the car to turn easier.

Front Axle Offset

- Measure from the left side frame rail to the inside of the left front axle bracket. Should measure approx. 2-3/4" to 2-7/8".

Torsion Bars/Springs

- Left Front Spring-120lbs to 125lbs
- Left Front Bar-.550 solid
.725 Hollow on '06 and older
- Left Rear Bar-.725 Solid Restricted '09 Cars,
.725 Hollow Stock or Multi
.725 Solid on '07 and older
- Right Front Spring-140lbs to 150lbs
- Right Front Bar-.575 Solid
- Right Rear Bar-.725 Solid Restricted '09 Cars,
.750 Hollow Stock or Multi
.725 Solid on '07 and older

Shocks

- Left Front-QA1 8262 or ARS 1062
- Right Front-QA1 8262-1 or ARS 1061/2
- Left Rear-QA1 8262-4 or ARS 1064/2
or Adjustable 2-8/2
- Right Rear-QA1 8264 or ARS 1064

Wing Angle/Location

- Short Track 12°-15°
- Long Track 8°-11°
- Start with trailing edge of wing approx. 4"-6" in front of rear axle.

Ride Height

- Measure the ride height without the driver and with 2 gallons of fuel. Place the car on a flat surface and measure from the ground to the center of the torsion bars. On a coil front measure from the ground to the bottom of the lower frame rail at the front cross member.

- Left Front Coil-3.50" to 3.75"
- Left Front Bar-10.50"
- Left Rear Bar-7.50"-7.75"
- Right Front Coil-4.25" to 4.50"
- Right Front Bar-11.25" to 11.50"
- Right Rear Bar-8.75"-9.00"

Note: Ride heights are without bolt on lead. Ride heights will be slightly lower with bolt on lead.

Tips to tighten the car on corner entry to apex.

- Lower right rear air pressure
- Move right rear wheel in ½" to 1"
- Decrease stagger
- Move wing back 1"-2"
- Change right rear shock to a #3 valving
- Move Jacobs ladder to inside top and bottom or outside top and bottom position.
- Reduce rebound on left rear shock.

Tips to tighten car on corner exit

- Raise front 4 turns on coil shocks and 1 turn on torsion bar front
- Decrease stagger
- Move wing back 1"-2"
- Add left rear weight distribution
- Change to #.5 valve rebound on right front shock and a #1 valve rebound on left front shock.

DIAPHRAGM BLEEDER MAINTENANCE - SPRINT

The bleeder works on the same principle as a High Speed By-Pass. Preset spring pressure against a Diaphragm that controls the amount of air that is to pass through the port. It releases air instantly in a 360 degree pattern. You don't have to compensate for what you think it may bleed off at. It repeats within 2/10 of a pound. With 4 different Springs, it has a range of 2 to 30 pounds.

Install the fiber washer first, then put poppit washer in center (bevel side up). Drop diaphragm in last with the little impression circle up. Note: the diaphragm usually does not go in flat. Use the spring to push up slowly from the bottom side. It will center itself. Hold the main body in one hand, and start the back piece in the threaded hole. Slowly spin the bottom piece until you feel it bottom. Tighten back piece with a # 10 line wrench (1 inch). Do not over tighten. Re-install nylon hose up through the hole opposite the muffler. Put spring on hose and leave enough hose exposed so you can insert it into the inlet. Push it into the little orange donut, about 3/16 inch. Slide spring down to the orange donut and pull extra hose outward until the spring is snug. Inspect the O-ring on the plastic piece that goes into the wheel. It gets a lot of abuse and should be changed if it is cut up or grooved. It completes the passage of air from the tire to the bleeder and is a place that could leak air. You can spray it with Windex or soapy water to see if it bubbles. If you see bubbles replace the O-ring. Install the spring and adjusting cap. Screw the end cap all the way down. It is easier to arrive at the poundage you want, by loosening the end cap slowly.

The air tank is the quickest and easiest method to set the bleeders. Put +/-10 lbs of air in the tank. Start loosening the end cap slowly. You will hear the bleeder vibrate. When you get close to your setting bring the lock ring up to the end cap. Tap the whole bleeder on the tank or table and watch the air gauge. Tapping the bleeder gives the same effect that it gets in the axle when the car is bouncing on the track. Readjust air pressure if necessary and then lock end cap tightly. You can also use your tire to set the bleeders, however the volume of air in the tire is greater than in the tank and it takes much longer.

Dirt and moisture are the enemy, and will adversely affect your bleeder. You should use screens on the wheel receivers to keep dirt out. Always plug the wheel when washing the car. Moisture can come from your air compressor. Drain it nightly or install a water separator in the air system. Using nitrogen will prevent moisture problems. If the bleeder does not bleed off quickly, your muffler is probably clogged. A good test is to remove the center inlet with a 7/64 Allen wrench, and then take the muffler out. Reinstall the center inlet and try again. If it vibrates, then you know the muffler is dirty. If the bleeder won't hold air, it is the diaphragm. Disassemble to make sure the diaphragm is free of dirt particles in the center impression of the diaphragm (the little circle). If it is clean of dirt, use graphite again

1. Remove adjusting cap and spring
2. Remove nylon line by depressing the orange donut on the center inlet, pull hose out
3. Remove nylon hose and spring from assembly
4. Holding bleeder with inlet and muffler facing upward, remove back piece (diaphragm will most likely come out still attached to the back piece)
5. Remove diaphragm, fiber washer, and poppit
6. Clean diaphragm with soap and water or 409. Do not use brake clean.
7. Wipe graphite off the washer and poppit
8. Clean back piece and O-ring assembly with 409 or equivalent
9. The back piece has a screen in the center inlet to keep dirt out. After cleaning use air to blow any dirt off the screen. Blow the muffler clean from the outside-in, as excess graphite will clog the muffler and stop the unit from working properly.
10. Wipe diaphragm with paper towel until dry. Use extra fine graphite (Carquest part # mz-2) put graphite in a little plastic container and drop diaphragms into graphite. Put the lid on and shake for about ten seconds. Remove diaphragms and set on paper towel with the center circle upward. Massage diaphragm with index finger until shiny. Blow off excess graphite or it will eventually clog the bronze muffler

PRO ELIMINATOR

Use Mobil-1 70-90

10" RING GEAR - 12 BOLT

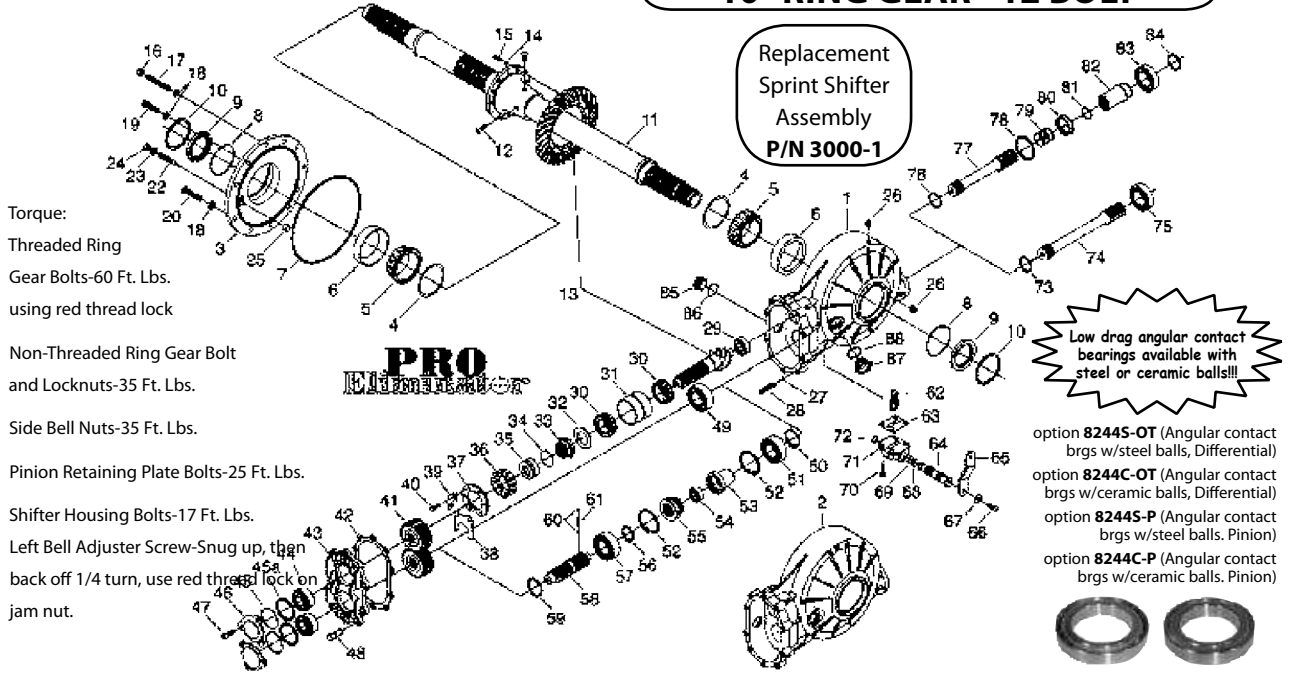

Torque:
 Threaded Ring
 Gear Bolts-60 Ft. Lbs.
 using red thread lock

Non-Threaded Ring Gear Bolt
 and Locknuts-35 Ft. Lbs.

Side Bell Nuts-35 Ft. Lbs.

Pinion Retaining Plate Bolts-25 Ft. Lbs.

Shifter Housing Bolts-17 Ft. Lbs.
 Left Bell Adjuster Screw-Snug up, then
 back off 1/4 turn, use red thread lock on
 jam nut.

- option **82445-OT** (Angular contact brgs w/steel balls, Differential)
- option **8244C-OT** (Angular contact brgs w/ceramic balls, Differential)
- option **82445-P** (Angular contact brgs w/steel balls, Pinion)
- option **8244C-P** (Angular contact brgs w/ceramic balls, Pinion)

1	Mag Pro Eliminator Center	27	5/16 Diameter Steel Ball, Gear Cover	54	Small Bearing, Stationary Coupler
2	X-Heavy Duty Mag Pro Eliminator Center	28	3/8-16 x 1 3/4" Stud, Gear Cover	55	Sliding Coupler
3	Mag Pro Eliminator Left Side Bell (w/caliper mounts)	29	Roller Bearing Cone, Pinion Shaft	56	External Snap Ring, Stub Shaft
4	Shim Kit, Axle Bearings	30	Bearing Cone, Pinion Shaft	64	Shifter Shaft
5	Bearing Cone, Axle	31	Double Bearing Cup, Pinion Shaft	65	Shift Arm
6	Bearing Cup, Side Bell	32	Bearing Washer, Pinion	66	3/8-24 x 3/4" HHCS, Shift Arm
7	O'Ring, Side Bell Seal	33	Posi-Lock Nut	67	3/8 Belleville Washer, Shift Arm
8	O'Ring, Side Bell Seal	34	O'Ring, Side Bell Seal	68	O'Ring Shifter Shaft (Large)
9	Seal Side Bell	35	Posi-Lock Retainer	69	O'Ring Shifter Shaft (Small)
10	Internal Snap Ring, Side Bell Seal	36	Retaining Ring, Pinion	70	5/16-18 x 7/8" 12 pt, Shift Housing
11	Aluminum Live Axle	37	Retainer Plate, Pinion	71	Shifter Housing, Magnesium
12	1/2-20 x 1" BHCS	38	Bearing Retainer	72	External Snap Ring, Shifter Shaft
13	Ring and Pinion	39	Lock Tab, Pinion Retainer Plate	73	Drive Shaft Snap Ring
14	3/8 Belleville Washer	40	3/8-16 x 1" HHCS, Retainer	74	Standard Lower Shaft, Shifter
15	Ring Gear Bolt	41	Quick Change Gear Set	75	Special Sealed Ball Bearing, Lower Shaft
16	7/16-20 Flanged Locknut (use with P/N 2266)		(not part of assembly)	76	Ext. Snap Ring, Lwr. Shaft for Integral Coupler
17	Stud Steel	42	Gasket, Gear Cover	77	Standard Lower Shaft, Shifter w/Integral Coupler
17	Stud Titanium	43	Heavy Duty Gear Cover (less bearings)	78	Spacer, Front Bearing
18	7/16 SAE Flatwasher	44	Double Row Ball Bearings w/Snap Ring	79	O'Ring Lower Shaft w/Integral Coupler
19	7/16-14 x 1-1/4" HHCS	45	O'Ring, Bearing Cap	80	Seal, Integral Coupler
20	7/16-14 x 1" HHCS	45	Back-up Ring, O'Ring	81	Internal Snap Ring, Integral Coupler
21	1/2-13 Adjusting Screw	46	Bearing Cap, Heavy Duty Gear Cover	82	Integral 10-10 Coupler, Steel
22	1/2 SAE Flatwasher	47	1/4-20 x 1" SHCS, Bearing Cap	82	Integral 10-10 Coupler, Alum
23	1/2-13 Aluminum Jam Nut	48	3/8-16 Aluminum High Nut, Gear Cover	83	Sealed Ball Bearing, Integral 10-10 Coupler
24	Thrust Block	49	Ball Bearing	84	External Snap Ring, Integral 10-10 Coupler
25	3/8 Pipe Plug	50	Snap Ring, Stationary Coupler	85	Inspection Plug
26	Plug w/O'Ring	51	Ball Bearing, Stationary Coupler	86	O'Ring Inspection Plug
		52	Internal Snap Ring, Rear Bearing	87	Large Inspection Plug
		53	Stationary Coupler	88	O'Ring, Inspection Plug

TORQUE SPECIFICATIONS

SpeedMart Tech Team

Torque Accuracy on Fasteners

Screw threads appear to be a simple concept yet much confusion and inconsistency exist regarding torque values. The mechanics of the screw thread are actually very complex and have numerous interacting variables. Sliding friction is affected by materials (like steel or aluminum on titanium), surface roughness, bearing area, material hardness, lubrication and so on.

Accuracy: Tightening is not an accurate science, look at the preloading accuracy published in the "Machinery's Handbook, 25th Edition, page 1404"

Method	Accuracy
By Feel	+/- 35%
Torque Wrench	+/- 25%
Turn-of-nut	+/- 15%
Preload washers	+/- 10%
Bolt elongation	+/- 3%
Bolt elongation Strain Gauges	+/- 1%

Recommended Torque Spec's for Titanium Fasteners

Use torque values specified by your equipment manufacture, when available. For titanium fasteners the torque values are listed below. We recommend anti-seize or moly paste be applied to the threads.

The importance of correct application cannot be overemphasized. Undertorque can result in unnecessary wear of nuts and bolts as well as the parts they hold together. When insufficient pressures are applied, uneven loads will be transmitted throughout the assembly which may result in excessive wear or premature failure due to fatigue. Overtorque can be equally damaging because of failure of the bolt or nut from overstressing the thread areas.

Torque Limits for American Size Bolts in Tension (For bolts in shear reduce the values shown below by 30-40%)

Non-lubricated			Lubricated		
Bolt Size	Min. Torque	Max. Torque	Bolt Size	Min. Torque	Max. Torque
5/16-18	80 in lbs	90 in lbs	5/16-18	72 in lbs	81 in lbs
5/16-24	120 in lbs	145 in lbs	5/16-24	108 in lbs	130 in lbs
3/8-16	160 in lbs	185 in lbs	3/8-16	144 in lbs	148 in lbs
3/8-24	200 in lbs	250 in lbs	3/8-24	180 in lbs	225 in lbs
7/16-14	235 in lbs	255 in lbs	7/16-14	211 in lbs	229 in lbs
7/16-20	520 in lbs	630 in lbs	7/16-20	468 in lbs	567 in lbs
1/2-13	400 in lbs	480 in lbs	1/2-13	360 in lbs	432 in lbs
1/2-20	770 in lbs	950 in lbs	1/2-20	693 in lbs	855 in lbs

PROFESSIONAL SERIES QUICK CHANGE GEARS

Made from aircraft steel for maximum strength. Each gear has a shaved finish to minimize backlash and run out, and is broached for proper 10 spline shaft fit. The SCS extra 5-step heat treating process yields maximum gear life for high stress applications such as big block Oswego Super Modifieds and World of Outlaws Sprint Cars. Gears have a black oxide finish, and the faces have been lightened to reduce rotating weight without sacrificing strength.

Gear Set No.	4.11 Ring & Pinion (9-37 Teeth)			4.86 Ring & Pinion (7-34 Teeth)	
	Low	High	No. Of Teeth	Low	High
SCS01	4.11	4.11	28/28	4.86	4.86
SCS02	3.96	4.26	27/28	4.68	5.04
SCS05	3.94	4.28	24/25	4.66	5.07
SCS15	3.90	4.33	19/20	4.61	5.12
SCS15K	3.85	4.38	15/16	4.56	5.18
SCS26	3.83	4.41	27/29	4.52	5.24
SCS06	3.78	4.46	23/25	4.47	5.28
SCS25	3.74	4.52	20/22	4.42	5.35
SCS12	3.68	4.58	26/29	4.36	5.42
SCS07	3.63	4.64	23/26	4.30	5.49
SCS07K	3.58	4.69	21/24	4.23	5.54
SCS17	3.55	4.76	19/22	4.19	5.63
SCS08K	3.49	4.83	17/20	4.13	5.71
SCS08	3.48	4.85	22/26	4.11	5.75
SCS19	3.45	4.89	21/25	4.08	5.78
SCS09K	3.42	4.93	25/30	4.05	5.83
SCS09	3.39	4.97	19/23	4.01	5.88
SCS11	3.35	5.04	22/27	3.96	5.97
SCS03	3.31	5.10	25/31	3.92	6.03
SCS13	3.29	5.14	20/25	3.89	6.08
SCS18	3.25	5.19	19/24	3.85	6.13
SCS04K	3.21	5.26	18/23	3.80	6.21
SCS04	3.18	5.31	24/31	3.76	6.28
SCS20	3.16	5.34	20/26	3.74	6.32
SCS22	3.12	5.41	19/25	3.69	6.39
SCS16	3.08	5.48	24/32	3.65	6.48
SCS10	3.04	5.55	20/27	3.60	6.56
SCS34	3.00	5.63	19/26	3.55	6.65
SCS14	2.95	5.72	23/32	3.50	6.76
SCS14K	2.93	5.76	20/28	3.47	6.81
SCS35	2.91	5.80	17/24	3.44	6.86
SCS32K	2.87	5.89	23/33	3.39	6.97
SCS24	2.83	5.96	20/29	3.35	7.04
SCS36	2.80	6.04	17/25	3.30	7.15
SCS37	2.78	6.07	23/34	3.29	7.18
SCS23	2.74	6.16	18/27	3.24	7.29
SCS21	2.69	6.28	17/26	3.18	7.43
SCS27	2.66	6.35	22/34	3.15	7.51
SCS43	2.63	6.42	16/25	3.11	7.59
SCS28	2.60	6.49	19/30	3.08	7.67
SCS29	2.57	6.58	15/24	3.04	7.77
SCS30	2.53	6.67	16/26	2.99	7.89
SCS41	2.49	6.77	17/28	2.95	8.00
SCS31	2.46	6.85	21/35	2.91	8.10
SCS33K	2.43	6.94	16/27	2.88	8.20
SCS33	2.41	7.00	17/29	2.85	8.28
SCS31K	2.39	7.05	14/24	2.83	8.33
SCS30K	2.37	7.12	15/26	2.80	8.42

Air Boxes (Radiator)..... 39, 40	Brake Pedals 45, 94	Frame Kits..... 16, 17, 35, 36
Air Density Gauges 50	Brake Rotors (Sprint)..... 90, 92, 93	Front Arms (Sprint)..... 104
Air Filters and Accessories 18, 54	Brake Rotors (Mini Sprint).....27	Front Arms (Mini Sprint)..... 24
Air Gauges (Tire PSI)..... 82	Brake Systems (Sprint)..... 90	Front Covers/Accessories..... 53
Air Tanks 81, 82, 108	Brake Systems (Mini Sprint)..... 26	Front End Kits 116
Aluminum Jacks77	Breathers (Engine)47	Front Hubs (Sprint)..... 115
AN Fittings..... 65, 66	Breathers (Rear End)..... 113	Front Hubs (Mini Sprint) 21, 22
AN Washers..... 42	Bumpers/Knerf Bars (Sprint)41	Front Wing Accessories..... 32, 122
AN Wrenches 78	Bumpers/Knerf Bars (Mini).....31	Fuel Filters 69
Apparel and Accessories..... 89	Bushings 24, 105	Fuel Funnels/Jugs..... 72
Arm Restraints..... 13	Bypass Springs/Pills/Accessories...70, 71	Fuel Injection Systems..... 47
Armguards 38, 39		Fuel Lube 74
Axle Nuts (Sprint) 113	Cage Nets 13	Fuel Pressure Regulator..... 70
Axle Nuts (Mini Sprint)..... 23	Camshaft Spuds/Accessories 63	Fuel Pumps (Sprint)..... 67, 68
Axle Rack87	Camshafts..... 56	Fuel Pumps (Mini Sprint)..... 19
Axle Spacer Kits (Sprint) 113	Carbon Fiber Body Panels 40	Fuel Tanks..... 19, 72, 73
Axle Spacer Kits (Mini Sprint) 23	Carbon Fiber Wing Caps.....32, 121	
Axles, Front (Sprint).....117	Carbon X 5	Gaskets (Engine)..... 62, 63
Axles, Front (Mini Sprint).....21	Chain & Accessories 20	Gaskets (Exhaust)..... 62
Axles, Front Kits (Sprint) 116	Chassis Kits (Sprint) 35, 36	Gaskets (Rear End) 113
Axles, Front Kits (Mini Sprint).....21	Chassis Kits (Mini Sprint)..... 16, 17	Gauges (Engine)..... 50
	Cylinder Heads..... 56	Gauges (Tire) 82
Bead Breakers 82	Coil Over Kits..... 100	Gear Bags 5
Bead Locks (Sprint).....106-109	Coil Over Springs 99	Gears..... 113
Bead Locks (Mini Sprint)..... 30	Connecting Rods..... 55	Gear Drives 56
Bearings (Sprint Birdcage) 103	Crankshafts..... 55	Gloves/Driver7
Bearings (Mini Sprint Birdcage) 23		Gloves/Mechanic 85
Bearings (Engine)..... 56	Drag Links 25, 101, 102	Grooving Irons/Accessories81
Bearings (Front Hubs)..... 115	Drive Shafts 116	
Bearings (Rear End) 113	Driver Suits 8, 9	Half Nut Kits..... 42
Bearings (Sprint Spindle) 115	Dry Sump Oil Pans 58	HANS Device 3
Bearings (Mini Sprint Spindle) ... 21, 22	Dry Sump Pumps57	Hats 89
Bell Crank Kits..... 48	Dry Sump Tank Mount 58	Header Accessories 61
Bell Cranks..... 48	Dry Sump Tanks 58	Headers (Sprint)..... 61
Bell Housing.....110, 111	Durometers 82	Heel Risers..... 40
Birdcages (Sprint) 103	Dzus Buttons/Accessories..... 31, 42	Heim Ends.....24, 25, 99, 101
Birdcages (Mini Sprint) 23		Helmet Accessories..... 4
Bladders (Sprint)..... 72, 73	Engine Accessories47-64	Helmets 1, 2
Bladders (Mini Sprint)..... 19	Engine Blocks 55	High Speed Bypass 70
Bleeders 108, 109	Engine Stands 83	High Speed Bypass Tester 64
Body Panels/Hoods (Sprint).....37-39	Engine Tools64, 79-81	Honeycomb (Radiator) 59
Bolt Kits (Sprint) 40, 45	Exhaust Systems (Sprint).....61	Hood Blankets 83
Bolt Kits Steel (Mini Sprint)..... 25		Hoods (Sprint) 37, 38
Bolt Kits Titanium25, 43-46	Fan Wear 89	Hoods (Mini Sprint)..... 16, 17
Books 83	Fasteners.....25, 42-46	Hubs (Sprint) 115
Brake Calipers (Sprint).....91	Filters (Air)..... 54	Hubs (Mini Sprint) 22
Brake Calipers (Mini Sprint) 26	Filters (Fuel) 69	Hydraulic Wing Components..... 123
Brake Fittings 65, 66	Filters (Oil/Adaptors)57	
Brake Fluid 74, 95	Fittings..... 65, 66	Ignition Systems48-52
Brake Lines 95	Floor Pan..... 39	Injection Systems/Accessories ...47, 48
Brake Mounts (Sprint)91-94		Injector Nozzles..... 71
Brake Mounts (Mini Sprint)27		Intake Manifolds 47
Brake Pads..... 26, 96		

Jacks	77	Power Steering Lines	120	Stop Watches	76
Jacobs Ladder/Straps.....	23, 102	Power Steering Pump	119	Sypers	81
Jam Nuts	24, 25, 99, 101	Proportioning Valve	94		
Jet Nut Kits.....	70, 71	Push Rods.....	56	Tachometers	50
Jets (Bypass Pills)	70, 71			Tank Covers	19, 83
		Quick Change Gears.....	113	Tanks and Bladders.....	19, 72, 73
King Pins (Sprint)	118	Quick Change Rear End	112	Tearoffs/Accessories	4
King Pins (Mini Sprint)	21	Quick Release Hub-Steering	119	Throttle Pedals.....	48
Knee Protectors	11			Throttle Linkage	48
Knerf Bars (Sprint)	41	Radiator Caps.....	60	Tie Rods.....	21, 101, 102
Knerf Bars (Mini Sprint).....	31	Radiator Honeycomb	59	Tie Wraps	85
Knock-off Tools	30, 82	Radiators	18, 59	Timing Covers	53
		Radius Rods (Sprint).....	101, 102	Timing Lights	79
Leak Down Testers	64	Radius Rods (Mini Sprint)	25	Tire Gauges	82
Lifters	56	Rear Arms (Sprint).....	104	Tire Groovers	81
Lower Shafts	113	Rear Arms (Mini Sprint)	24	Tire Tools.....	81, 82
Lubes	74, 75	Rear End Repair Accessories	113	Tires	30, 107
		Rear Ends	112	Titanium Bolts/Kits	43-46
Magnetos/Accessories.....	49-52	Restrictors (Injection)	47	Tools	76-88
Master Cylinders (Sprint)	90	Rivets/Rivet Guns	77	Top Wing Mounts.....	121
Master Cylinders (Mini Sprint)	26	Rock Screens	14, 40	Top Wings (Sprint)	121
Mini Sprint Accessories	32	Rocker Arms	56	Top Wings (Mini Sprint)	32
Motor.....	47-64	Rod Ends	24, 25, 99, 101	Torque Balls.....	110, 111
Motor Plates.....	39, 58	Roll Bar Padding	14	Torque Tubes	110, 111
Mudd X-Mud Off	75, 84			Torsion Arms (Sprint)	104
Muffler (Sprint).....	61	Safety Equipment.....	1-15	Torsion Arms (Mini Sprint)	24
Muffler Clamps	62	Safety Wire/Tools.....	77	Torsion Bar Accessories...24, 104, 105	
		Seat Accessories	10, 11	Torsion Bars (Sprint).....	105
Nose Wing Mounts	32, 122	Seat Belts	12, 13	Torsion Bars (Mini Sprint).....	24
Nose Wings (Sprint).....	122	Seats	10, 11	Torsion Stops.....	24, 105
Nose Wing (Mini Sprint)	32	Set-Up Blocks	76	Trailer Accessories	86-88
Nozzles	71	Shields (Helmet)	4		
Nut Kits.....	42	Shifter Cables.....	20, 114	U-Joints.....	111
Nuts-Axle (Sprint)	113	Shifters (Sprint)	114		
Nuts-Axle (Mini Sprint)	23	Shifters (Mini Sprint)	20	Valve Covers/Accessories	47
		Shock Accessories	28, 29, 97-100	Valve Spring Tools	64, 80
Oil	74	Shocks.....	28, 29, 97-100	Valve Springs.....	63
Oil Filters.....	57	Shoes	6, 89	Valve Train/Accessories.....	47, 56
Oil Pans	58	Shut Off (Fuel)	68		
Oil Pumps.....	57	Side Panels	37-40	Washer Kits	42
Oiling Systems/Accessories.....	57, 58	Socks	5	Water Pumps	53
Outerwears.....	54	Scales.....	76	Water Wetter	75
		Spacers (Wheel).....	23, 113	Watts Links (Sprint).....	102
Pills-Injection	70, 71	Spark Plug Wires.....	49, 51	Watts Links (Mini Sprint).....	23
Piston Rings	56	Spark Plugs	51	Weather Stations	50
Pistons	55	Spindles (Sprint)	117	Wheel Accessories.....	30, 108, 109
Pit Tools/Accessories	83-85	Spindles (Mini Sprint)	21	Wheel Wrenches	30, 109
Pitman Arms.....	120	Sprocket	20, 23	Wheels.....	30, 106, 107
Plug Wires	49, 51	Steering Accessories.....	21, 119-123	Wing Accessories.....	32, 122, 123
Plumbing.....	65, 66, 68	Steering Arms (Sprint)	118	Wing Caps.....	32, 121
PMP Components.....	16, 18-32	Steering Arms (Mini Sprint)	21	Wing Mounts	121-123
Power Steering.....	119, 120	Steering Boxes	119	Wings	121
		Steering Wheels.....	120	Wing Lines	123
				Youth / Junior Safety	15